

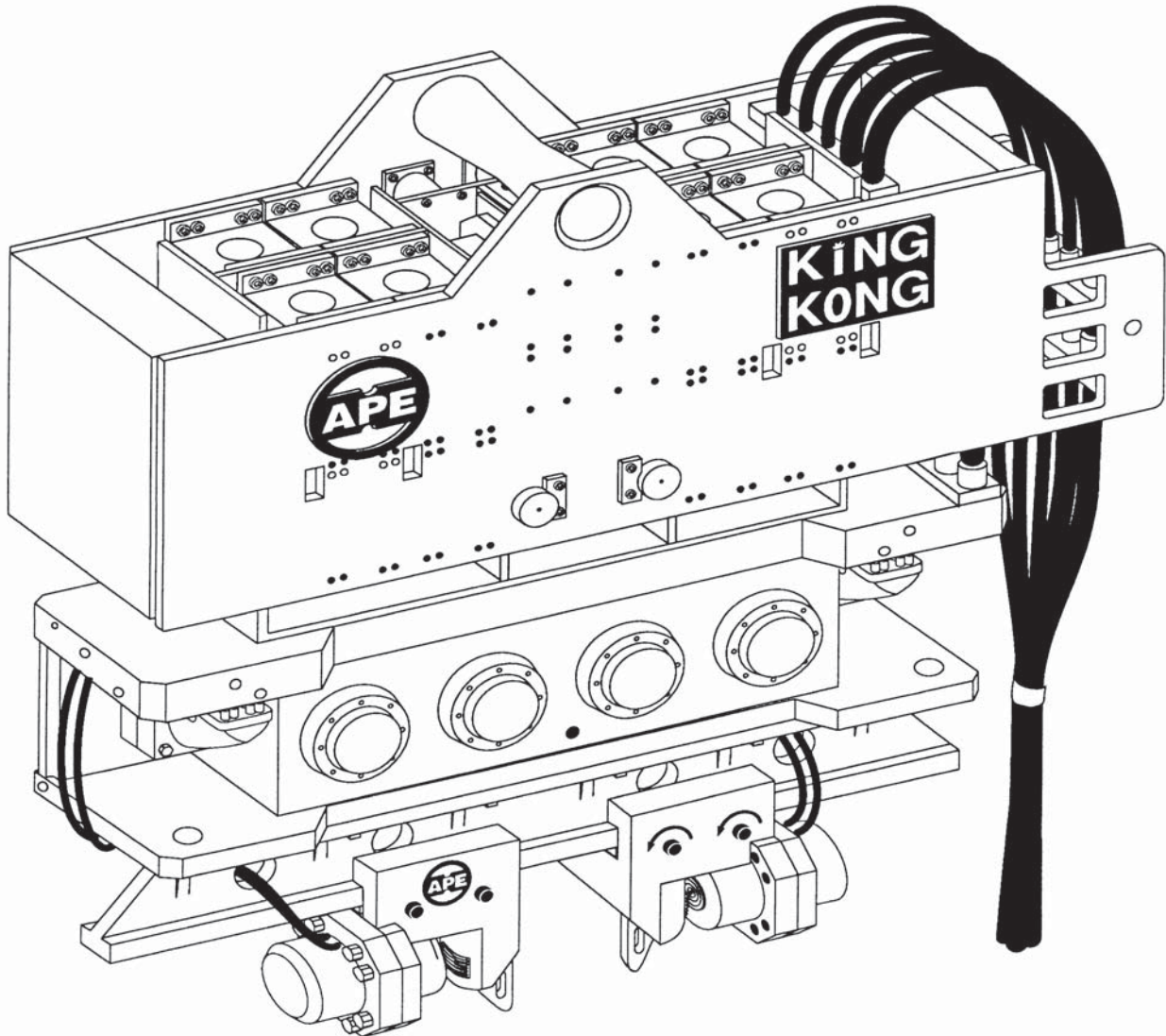

OPERATION / MAINTENANCE MANUAL

MODEL 400 VIBRATORY DRIVER WITH MODEL 1200 POWER UNIT

7032 SOUTH 196th - KENT, WA. 98032 - (253) 872-0141 / FAX (253) 872-8710



SERIAL NUMBER:

**MODEL 400 VIBRO
WITH MODEL 1200 POWER UNIT**



OPERATION / MAINTENANCE MANUAL

MODEL 400 VIBRATORY DRIVER WITH MODEL 1200 POWER UNIT

7032 SOUTH 196th - KENT, WA. 98032 - (253) 872-0141 / FAX (253) 872-8710

Revision Record

Change Number	Page Number	Date	Revision Description
		2-2013	INITIAL PRINTING
1	2-20, 2-21	3/20/19	UPDATED PN ON CLAMP COMPONENTS
2	2-8	5/9/19	ADDED MISSING PN's TO ITEMS 2, 3, 4, 5, 6, 8, 10, 11, 12



OPERATION / MAINTENANCE MANUAL

MODEL 400 VIBRATORY DRIVER WITH MODEL 1200 POWER UNIT

7032 SOUTH 196th - KENT, WA. 98032 - (253) 872-0141 / FAX (253) 872-8710

Preface

General

This manual covers the **Model 400 Vibratory Driver/Extractors and the Model 1200 Power Unit**. Most information contained in this manual is identical for all the models covered. The data provided in this manual gives the necessary information to operate and maintain APE equipment. The listed procedures are to be performed by qualified personnel who have an understanding of the equipment and who follow all safety precautions.

Guide to Using the Manual

1. Refer to the Table of Contents for the page location of applicable sections.
2. All weights and measurements in this manual are in both English and Metric units.
3. The manual will be revised as necessary to reflect current information.

Abbreviations

The following are abbreviations used within this manual.

lbs.	= Pounds	HCLW	= High Collar Lock Washer
psi.	= Pounds per Square Inch	P/N	= Part Number
hp.	= Horse Power		
gpm.	= Gallons Per Minute		
rpm.	= Revolutions Per Minute		
eng.	= Engine		
cyl.	= Cylinder		
mm.	= Millimeter		
mtg.	= Mounting		
S/N	= Serial Number		
sol.	= Solenoid		

Serial Number Locations

1. **VIBRATOR:** Above and in between the eccentric covers on both sides of the machine.
2. **POWER UNIT:** On both sides in front of reservoir near the top.



OPERATION / MAINTENANCE MANUAL

MODEL 400 VIBRATORY DRIVER WITH MODEL 1200 POWER UNIT

7032 SOUTH 196th - KENT, WA. 98032 - (253) 872-0141 / FAX (253) 872-8710

Table of Contents

	Page
Revision Record	i
Preface	ii
Table of Contents	iii-iv
Safety Precautions	v
Warranty	vii
 I. GENERAL INFORMATION	
I-1. Machine Features 400 Vibratory Hammer	1-2
I-2. Machine Specifications	
A. Model 400 Vibro.....	1-3
B. Model 1200 Power Unit	1-3
I-3. General Description of 400 Vibro.....	1-4
A. Suppressor Housing	1-5
B. Vibrator Gearbox	1-6
C. Clamp Attachment	1-7
D. Optional Attachments	1-8
I-4. General Description of Model 1200 Power Unit	1-9
 II. MAJOR COMPONENT DEFINITION	
II-1. Model 400 Final Assembly Identification	2-2
II-2. Suppressor Identification	2-4
II-3. Gearbox Identification.....	2-6
II-4. Check Valve Identification.....	2-10
II-5. 196 Clamp Identification 800609	2-12
II-6. 196 Clamp Identification 800631	2-14
II-7. Hose Bundle	2-16
II-8. Model 1200 Power Unit Skid Identification	2-18
II-9. 2" Quick Disconnect Coupling Identification	2-19
II-10. 200 Caisson Clamp Identification	2-20
II-11. 200 Caisson Clamp Cylinder Identification	2-21
II-12. Control Panel.....	2-22
II-13. Control Panel Gages	2-25
II-14. Control Pendant.....	2-26
 III. LOADING AND UNLOADING.....	
III-1. Model 400 Vibratory Driver	3-1
III-2. Model 1200 Power Unit	3-1
III-3. What to do if damaged during shipment.....	3-1
 IV. PREPARATION AND OPERATION	
IV-1. Rigging of Vibratory Driver.....	4-1
IV-2. Installing the Clamp Attachment	4-1
IV-3. Plumbing the Vibro Hoses to the Power Unit.....	4-2
IV-4. Filling Vibrator Pressure Hoses	4-3
IV-5. Bleeding Clamp Attachment Hydraulic Hoses	4-3
IV-6. Precautions and Rules for Operation	4-4
IV-7. Relief Valve Settings Prior to Operation	4-5
IV-8. Shut-down Procedures	4-7
IV-9. Suppressor Housing - Gearbox Mating	4-7
IV-10. Operation of the Control Pendant.....	4-8
IV-11. Normal Steps to Operate Vibrator	4-8



OPERATION / MAINTENANCE MANUAL

MODEL 400 VIBRATORY DRIVER WITH MODEL 1200 POWER UNIT

7032 SOUTH 196th - KENT, WA. 98032 - (253) 872-0141 / FAX (253) 872-8710

V. MAINTENANCE

V-1.	Daily Maintenance Required Prior to Operation.....	5-1
V-2.	Checklist After Power Unit Engine Has Started	5-1
V-3.	Maintenance and Adjustments: (75 Hours) (for lubrication see V-6) .	5-2
V-4.	Maintenance and Adjustments: (Eccentric Bearings)	5-2
V-5.	Maintenance and Adjustments in Severe Conditions.....	5-2
V-6A.	Lubrication Vibratory Gearbox	5-2
V-6B.	Clamp Attachment.....	5-2
V-7A.	Power Unit Filters, Fluid Types and Capacities.....	5-3
V-7B.	Power Unit Hydraulic Fluid.....	5-4
V-7C.	Power Unit Two Part Hydraulic Fluid Tank	5-4
V-7D.	Power Unit Draining and Filling Hydraulic Fluid Tank	5-4
V-7E.	Power Unit Changing Hydraulic Return Filter Element	5-5
V-7F.	Power Unit Steps to Remove the Hydraulic Filter Elements	5-5
V-8.	Bolt Torque Information	5-6
V-9.	Power Unit Pump drive	5-7

VI. TROUBLE - SHOOTING: Model 400 Vibro.....	6-1
---	------------

VII. MODEL 1200 POWER UNIT

VII-1.	Hydraulic Circuitry	7-2
VII-1A.	Clamp Circuit.....	7-2
VII-1B.	Drive Circuit.....	7-2
VII-1C.	Hydraulic Schematic	7-3
VII-1D.	Hydraulic Components - Clamp / Drill Manifold	7-4
VII-1E.	Hydraulic Components - Drive Manifold.....	7-6
VII-1F.	Hydraulic Components - Hose Identification and Routing.....	7-9
VII-1G.	Hydraulic Components - Hydraulic Tank Connections	7-10
VII-1H-K.	Hydraulic Components - Misc	7-12
VII-1L.	Hydraulic Components - Hydraulic Pumps	7-13
VII-2.	Electrical Controls	7-14
VII-2A.	Main Circuit Breaker.....	7-14
VII-2B.	Tachometer	7-14
VII-2C.	Hourmeters	7-14
VII-2D.	Engine Safety Shutdown Switch	7-14
VII-2E.	Murphy "Engine Oil Press" gage.....	7-15
VII-2F.	Murphy "Engine Coolant Temp" gage	7-15
VII-2G.	Murphy "Hyd Oil Temp" gage	7-15
VII-2H.	Hydraulic Oil Level Float Switch.....	7-15
VII-2I.	"Emergency Stop" button	7-15
VII-2J.	Pilot lights.....	7-16
VII-2K.	Engine Control Switches"OFF-ON-START"	7-16
VII-2L.	"LOCAL--PENDANT" Switch.....	7-16
VII-2M.	Governor Control Switches "RAISE-off-LOWER"	7-17
VII-2N.	Clamp Control Switches ("OPEN-off-CLOSE")	7-17
VII-2O.	Drive Control Switches ("FORWARD/off/REVERSE")	7-19
VII-2P.	Preparing the Electrical System for Engine Startup	7-19
VII-2Q.	Electrical Schematic.....	7-20
VII-2R.	Electrical Symbol Legend.....	7-21
VII-3.	Control Pendant	7-22
VII-3A.	Control Pendant Wiring Diagram	7-23
VII-4	Recommended Bolt Tightening Torque	7-24



OPERATION / MAINTENANCE MANUAL

MODEL 400 VIBRATORY DRIVER WITH MODEL 1200 POWER UNIT

7032 SOUTH 196th - KENT, WA. 98032 - (253) 872-0141 / FAX (253) 872-8710

Safety Precautions

(This list of precautions must be followed at all times to ensure personal & equipment safety.)

1. Read this manual from beginning to end before operating or working on this machine.
2. When operating in a closed area, pipe exhaust fumes outside. (**WARNING:** Breathing exhaust fumes can cause serious injury and even death.)
3. When servicing batteries, avoid any type of spark or open flame. Batteries generate explosive gases during charging. There must be proper ventilation when charging batteries.
4. Never Adjust or repair the unit while it is in operation.
5. Make sure the Control Pendant is in the "OFF" position before starting the unit.
6. Remove all tools and electrical cords before starting the unit.
7. Keep oily rags away from the exhaust system.
8. Never store flammable liquids near the engine.
9. Never stand under vibro at any time and keep your eyes on the vibro when it is in operation. Keep a look out for loose bolts or leaking hydraulic lines.
10. Avoid pulling on hose quick dis-connect fittings. Move power unit closer to work if hoses cannot reach. Do not use hoses as a tow line to tug the power unit! If a hose fails at the hydraulic couplers then it is a result of "hose tugging by the pile crew".
11. Avoid kinks in the hoses. Kinks will cut the hose safety factor by 50 percent.
12. Always wear eye and ear protection.
13. Avoid standing downwind of vibrating piles. Dirt and other matter may become airborne and fall into the unprotected eye.
14. Always wear a hardhat, gloves, and safety shoes.
15. When moving, driving or extracting pile, always attach safetyline between pile and crane hook.
16. (**WARNING**) Never clamp vibro to pile and dis-connect from crane line. Lay vibro down on ground when not in use.
17. Do not truck power unit with quick disconnect caps and plugs screwed on to fittings unless the caps and plugs have wire rope safety lines attached. Store in storage box under control panel.



OPERATION / MAINTENANCE MANUAL

MODEL 400 VIBRATORY DRIVER WITH MODEL 1200 POWER UNIT

7032 SOUTH 196th - KENT, WA. 98032 - (253) 872-0141 / FAX (253) 872-8710



OPERATION / MAINTENANCE MANUAL

MODEL 400 VIBRATORY DRIVER WITH MODEL 1200 POWER UNIT

7032 SOUTH 196th - KENT, WA. 98032 - (253) 872-0141 / FAX (253) 872-8710

Warranty

American Piledriving Equipment, Inc.
STANDARD WARRANTY

American Piledriving Equipment, Inc. (APE/J&M) warrants new products sold by it to be free from defects in material or workmanship for a period of one year after the date of delivery to the first user and subject to the following conditions: APE/J&M's obligation and liability under this WARRANTY is expressly limited to repairing or replacing at APE/J&M's option, any parts which appear to APE/J&M upon inspection to have been defective in material or workmanship. Such parts shall be provided at no cost to the user, at the business establishment of APE/J&M or the authorized APE/J&M distributor of the product during regular working hours. This WARRANTY, shall not apply to component parts or accessories of products not manufactured by APE/J&M and which carry the warranty of the manufacturer thereof, or to normal maintenance (scraped and scived lube and fuel lines, worn cushion material in the drive base) or normal maintenance parts (such as fouled injectors, weakened check valve springs, damaged grease zirts caused by use over time). Replacement or repair parts installed in the product covered by this WARRANTY are warranted only for the remainder of the warranty as if such parts were original components of said product. APE/J&M makes no other warranty, expressed or implied and makes no warranty of merchantability of fitness for any particular purpose.

APE's obligation under this WARRANTY shall not include any transportation charges, costs of installation, duty, taxes or any other charges whatsoever, or any liability for direct, indirect, incidental or consequential damage or delay. If requested by APE/J&M, products or parts for which a warranty claim is made are to be returned transportation prepaid to APE/J&M. Any improper use, including operation after discovery of defective or worn parts, operation beyond rated capacity, substitution of any parts whatsoever, or parts not approved by APE/J&M or any alteration or repair by others in such manner as in APE/J&M's judgment affects the product materially and adversely, shall void this warranty.

ANY TYPE OF WELDING ON EQUIPMENT
WILL VOID THE WARRANTY

Refusal: Vibros: If the pile does not move one foot in 30 seconds of vibro operation at full speed. Resort to a larger vibro. APE/J&M equipment may exceed the refusal driving criteria for short periods of time as may be needed to penetrate hard soil layers or obstacles. In such cases, a heat gun is used to monitor the temperature of the bearings and related components to prevent use of the machine beyond 210 degrees F. Contact APE/J&M or your local APE/J&M distributor for special instructions when faced with refusal conditions.

Refusal: Diesels: Do not exceed 10 blows per inch or 120 blows per foot. In cases of setting of the pile it is permitted to increase the blow count to 250 blows per foot, but only for one foot of driving penetration. Pile inspectors should consult the APE factory for permission to exceed these limits. Failure to do so will void the warranty. This standard specification is accepted by the DFI (Deep Foundations Institute) and the PDCA (Pile Driving Contractors Association) and by all manufacturers of pile driving equipment.



OPERATION / MAINTENANCE MANUAL

MODEL 400 VIBRATORY DRIVER WITH MODEL 1200 POWER UNIT

7032 SOUTH 196th - KENT, WA. 98032 - (253) 872-0141 / FAX (253) 872-8710

I-1. Machine Features. - Model 400 Vibratory Hammer

Patented breakthrough suppressor cuts down weight while increasing line pull.

The Model 400 outperforms other vibros in its class. It is lighter and allows more pull and reach.

The heavy duty lifting pin allows easy rigging of the vibro and two safety pins ensure maximum safety.

More pulling ability than other comparable vibros.

Suppressor is modular and can be removed to reduce suspended weight and height.

One piece eccentric/gear design eliminates bolts, keyways, splines and pins.

Eccentrics filled with "heavy metals" produce more amplitude with less parts.

Gear box incorporates a machined O-ring groove to seal the top plate with no leaky gaskets.

Giant spherical bearings are five times larger than those found on other machines.

Heavy cylinder needs no guards and all hoses are tucked out of harms way. The one piece design eliminates rear seals, tie rods & nuts.

Hydraulic motors are recessed which eliminates the need for bolted on guards. Less parts - less problems.

Rifle bored top plate eliminates unwanted hoses that can cause serious downtime.

Computer designed gear-box is perfectly balanced with low center of gravity. Release crane line without the worry of bending piles.

The 400 vibro can be shipped fully assembled on one truck.

Gear box drilled to accept attachments manufactured by APE and by other manufacturers.

High speed gear train will allow vibro to operate off many different power units.

Patented breakthrough suppressor cuts down weight while increasing line pull.

The Model 400 outperforms other vibros in its class. It is lighter and allows more pull and reach.

The heavy duty lifting pin allows easy rigging of the vibro and two safety pins ensure maximum safety.

Suppressor is modular and can be removed to reduce suspended weight and height.

One piece eccentric/gear design eliminates bolts, keyways, splines and pins.

Eccentrics filled with "heavy metals" produce more amplitude with less parts.

Giant spherical bearings are five times larger than those found on other machines.

Heavy cylinder needs no guards and all hoses are tucked out of harms way. The one piece design eliminates rear seals, tie rods & nuts.

Hydraulic motors are recessed which eliminates the need for bolted on guards. Less parts - less problems.

Computer designed gear-box is perfectly balanced with low center of gravity. Release crane line without the worry of bending piles.

The 400 vibro can be shipped fully assembled on one truck.

Gear box drilled to accept attachments manufactured by APE and by other manufacturers.

High speed gear train will allow vibro to operate off many different power units.

Figure 1-A. Machine Features



OPERATION / MAINTENANCE MANUAL

MODEL 400 VIBRATORY DRIVER WITH MODEL 1200 POWER UNIT

7032 SOUTH 196th - KENT, WA. 98032 - (253) 872-0141 / FAX (253) 872-8710

I. GENERAL INFORMATION

I-2. Machine Specifications

I-2A. Model 400 Vibro

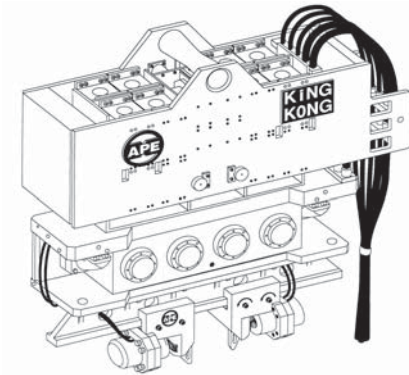

Model 400

Eccentric Moment	11,500 in-lbs (132.49 kg-M)
Drive Force	320 Tons (2,847 kN)
Frequency (cpm)	400 to 1,400
Amplitude w/dual clamps	1.63" (40 mm)
Pile Clamp Force	196 Tons (1,744 kN)
Line Pull for Extraction*	208 Tons (1,850 kN)
Hydraulic Hose Length	150' (45 m)
Suspended Weight**	56,000 lbs. (25,401 kg)
Length	143" (3637 mm)
Width at Throat	33" (838 mm)
Height***	110" (2794 mm)

* Line pull is based on elastomers being used: Red elastomers allow 228 tons(2,028 kN) vs the Black elastomers allow the capacity of 250 tons (2,224 kN).

** Weight includes Quad clamp system and 1/2 of hose bundle.

*** Height includes 8' beam and clamps.

Table 1-A. - Vibro

I-2B. Model 1200 Power Unit

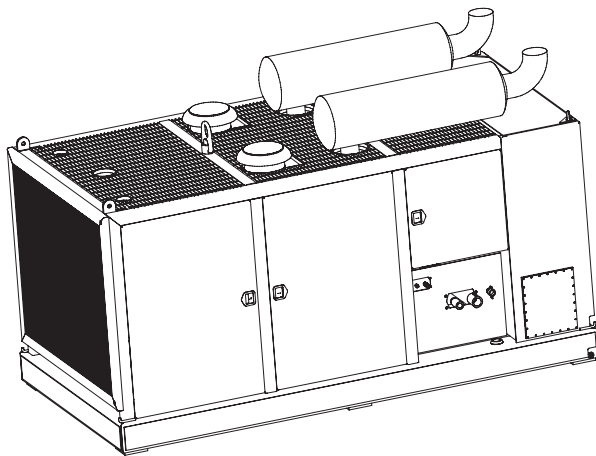

Model 1200

Engine	1050 hp. (783 kW) Caterpillar C27
Maximum Power	1200 hp (895 kW)
Operating Speed	800 to 2050 rpm
Maximum Drive Pressure	4,800 psi (331 bar)
Hyd. Flow-FWD/REV	190 gpm (720 lpm)
Clamp Pressure	4,800 psi (331 bar)
Clamp Pump Flow	7.8 gpm (29.5 lpm)
Weight	22,500 lbs (10,206 kg)
Length	168.5" (4280 mm)
Width	87.25" (2216 mm)
Height	103" (2616 mm)

Table 1-B. - Power Unit



OPERATION / MAINTENANCE MANUAL

MODEL 400 VIBRATORY DRIVER WITH MODEL 1200 POWER UNIT

7032 SOUTH 196th - KENT, WA. 98032 - (253) 872-0141 / FAX (253) 872-8710

I. GENERAL INFORMATION

I-3. General Description of Model 400 Vibro

The **APE Model 400** is a variable frequency vibratory pile driver/extractor designed to drive and extract all types of piles including sheet, pipe, timber, concrete, H-beam, I-beam and steel plates. In addition, the vibrator can be used for soil compaction, installing well casings, and installation of tie-backs and wick drains.

The Model 400 operates in a frequency range of 400 to 1,400 cycles per minute depending on the hydraulic flow and on the hydraulic motors fitted to the gear train.

The three major parts to the Model 400 are as follows:

- A.) The Suppressor housing.
- B.) The Gearbox.
- C.) The Clamp Attachment.

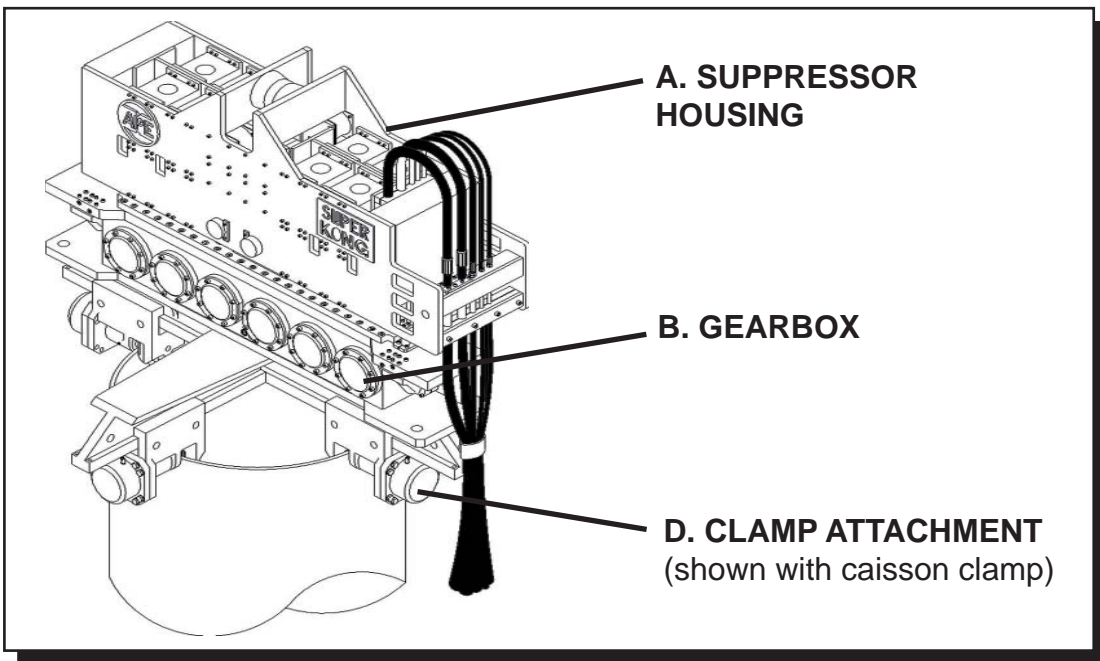

Figure 1-B. General Description of 400 Vibro.

I. GENERAL INFORMATION

I-3A. Suppressor Housing

The suppressor housing utilizes a total of sixteen, first stage large elastomers and eight small, second, stage small elastomers. During extraction, the first stage displaces approximately 10 inches and then engages the inner second stage and engagement pin plate. The engagement pin will then come into motion and provide an additional 6 inches until the safety pin bottoms out in the visual slot registering the total line pull with a total maximum line pull of 190 tons to 208 tons depending upon the stiffness of the elastomers installed. When the second stage is engaged you must be fully engaged in the second stage. Bouncing on the safety pin between stages is damaging. (**WARNING! Hard pulling for long periods of time will heat and damage the large elastomers. The heat generated from constant heavy line pull will destroy the chemical bond between the rubber and mounting plate which will cause elastomer failure.**) When engaged in hard extracting, break every 15 minutes to allow elastomers to cool.

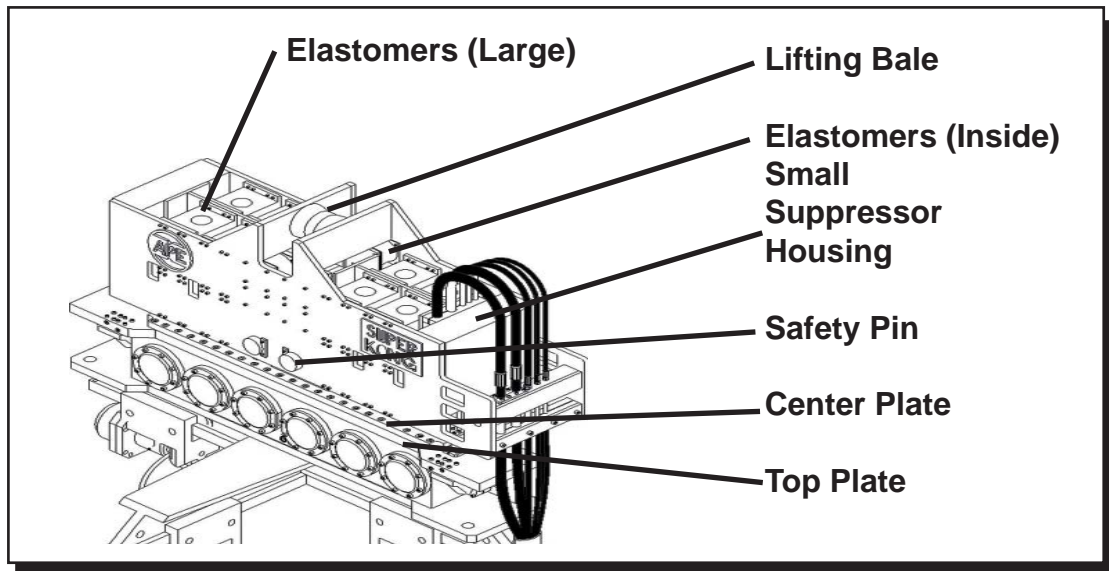

Figure 1-C. General Description of Suppressor Housing.



OPERATION / MAINTENANCE MANUAL

MODEL 400 VIBRATORY DRIVER WITH MODEL 1200 POWER UNIT

7032 SOUTH 196th - KENT, WA. 98032 - (253) 872-0141 / FAX (253) 872-8710

I. GENERAL INFORMATION

I-3B. Vibrator Gearbox

The vibrator gearbox contains four high amplitude eccentric weights cast in one piece with the gear. This design is unique to the industry and was developed by the engineers of APE to solve a number of problems associated with other types of vibrator machines. The eccentric and the drive gears have been helically cut to provide high speed operation with reduced noise and wear. Vibration is caused by the vertical movement created when the eccentrics are rotated. The eccentrics and drive gears are all driven in line by hydraulic motors tucked in on the outboard side of the gearbox. The motors are recessed for maximum protection. The eccentrics rotate on four shafts housed by eight giant spherical bearings. The gears and bearings receive lubrication as a result of the fluid splashing inside the gearbox when the gears are rotated. The oil level is quickly determined by looking at the site gauge. The Model 400 can be operated under water to a depth of 30 feet without modifications. (Consult factory for depths below 30 feet.)

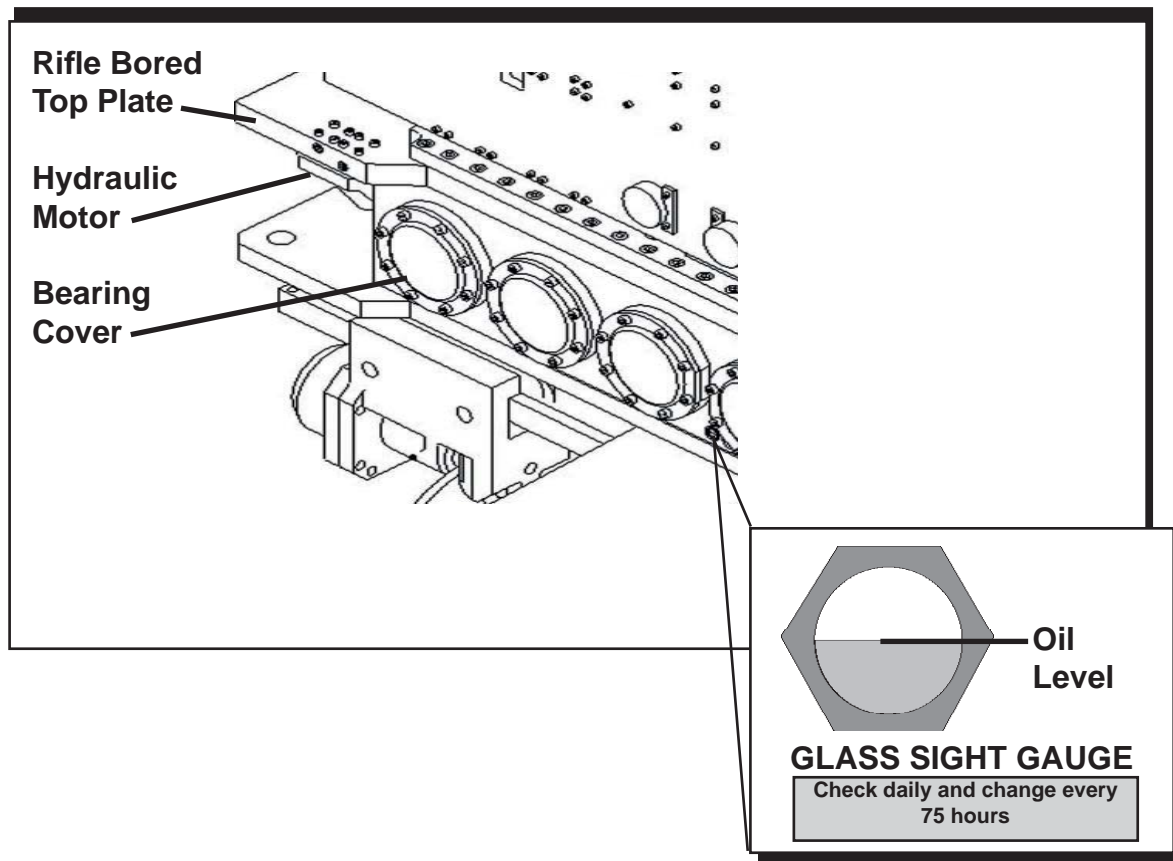

Figure 1-D. General Description of Vibrator Gearbox.

I. GENERAL INFORMATION

I-3C. Clamp Attachment

The APE 400 comes with a **Caisson Beam and Caisson Clamps** or a **Sheet Clamp**. Each of the clamps contain two gripping jaws. One is "fixed" and one is "moveable". A large hydraulic cylinder operates the moveable jaw with up to 196 tons of clamping force depending on clamp pump relief pressure. The jaws open and close by turning a switch on the remote control pendant or may be operated by turning the switch at the main control panel mounted on the power unit. **The APE Caisson Clamp** can be used for driving and extracting caissons from 16 inches to 9.5 feet. (for larger diameters contact APE) The clamps are held in place with a simple wedge-lock design. Clamps can be fitted with hydraulically activated wedges for faster adjustments when driving more than one size caisson. (Contact APE or your local APE distributor for more information on clamp attachments for special pile types.)

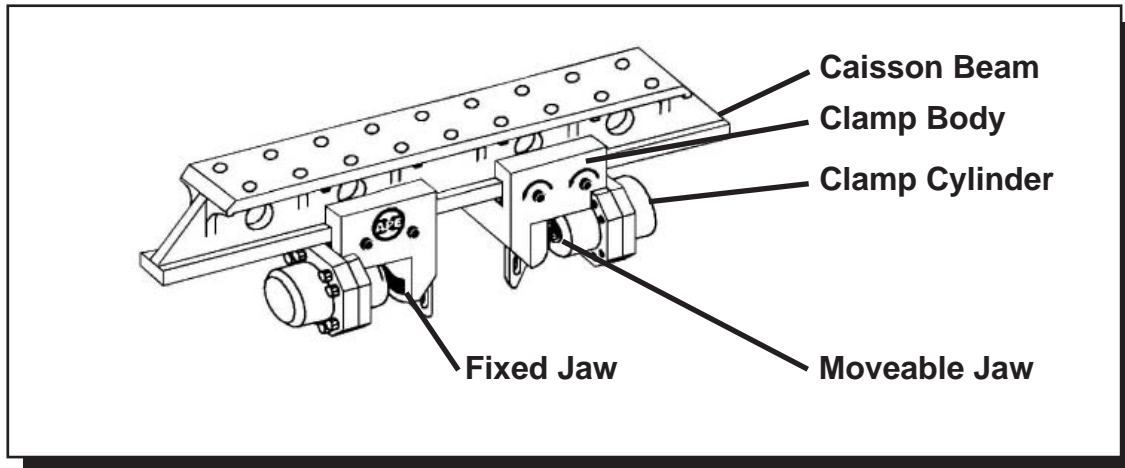
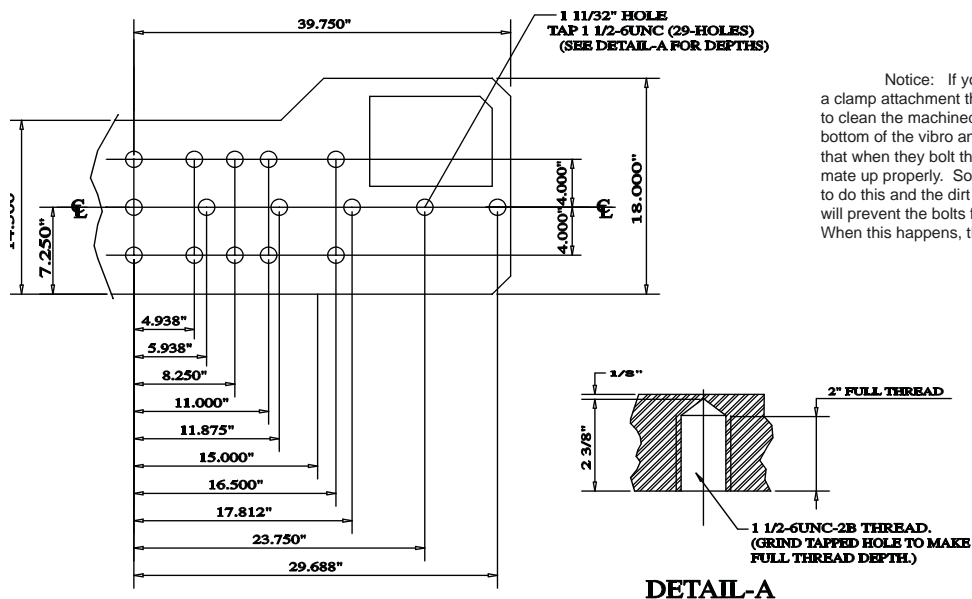

Figure 1-E. General Description of Clamp Attachment.



Notice: If you are involved in changing a clamp attachment then please train your crew to clean the machined surfaces of both the bottom of the vibro and the top of the clamp so that when they bolt the two together they will mate up properly. Sometimes a crew will forget to do this and the dirt or dent in the metal plates will prevent the bolts from becoming fully tight. When this happens, the clamp bolts break.

Figure 1-F. Clamp Attachment Hole Configuration.



OPERATION / MAINTENANCE MANUAL

MODEL 400 VIBRATORY DRIVER WITH MODEL 1200 POWER UNIT

7032 SOUTH 196th - KENT, WA. 98032 - (253) 872-0141 / FAX (253) 872-8710

I. GENERAL INFORMATION

I-3D. Optional Attachments

The following are some of the optional attachments for the Model 400 Vibratory hammer. (Contact APE or your local APE distributor for more information about these and other available equipment.)

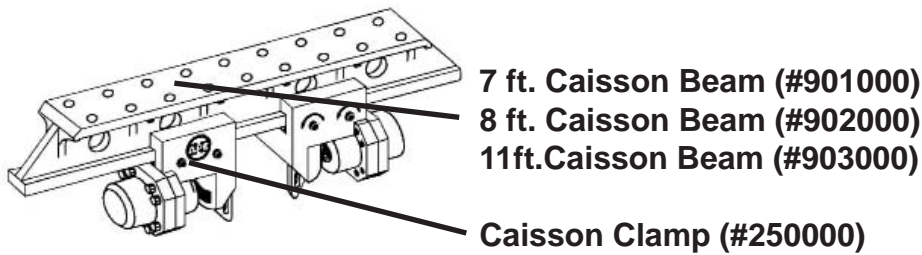

APE CAISSON CLAMP

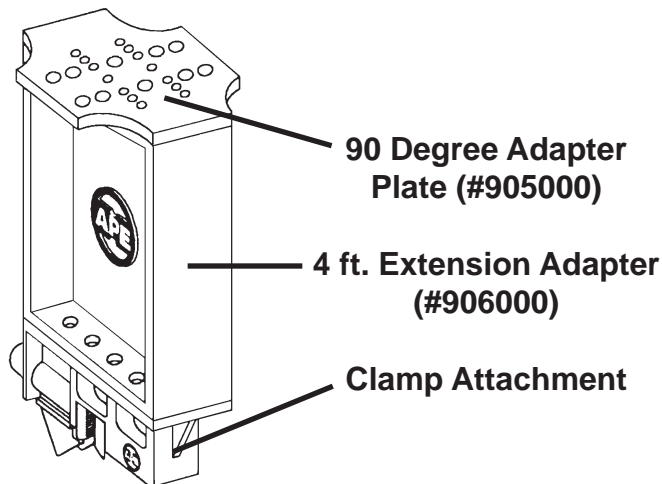

**APE 90 DEGREE
ADAPTER WITH EXTENSION**

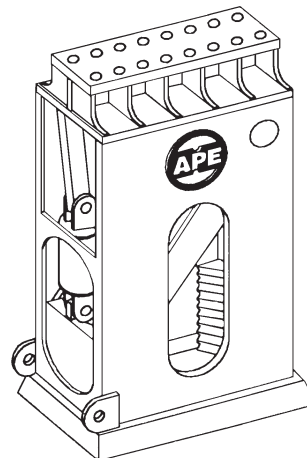

**APE DELUXE WOOD CLAMP
(#907000)**

Figure 1-G. Optional Attachments



OPERATION / MAINTENANCE MANUAL

MODEL 400 VIBRATORY DRIVER WITH MODEL 1200 POWER UNIT

7032 SOUTH 196th - KENT, WA. 98032 - (253) 872-0141 / FAX (253) 872-8710

I. GENERAL INFORMATION

I-4. General Description of Model 1200 Power Unit

The 400 vibrator runs off the APE 1200 power unit. The APE 1200 has a 1200 horsepower (895 kW) CATERPILLAR C32 engine. The engine is mounted to a tubular frame that also serves as a diesel fuel tank. A sheet metal and tube frame covers the engine and is equipped with locking doors for protection from the environment. A control panel is located behind one of the doors and comes complete with a 50 foot (15.2 M) control pendant. There are two hydraulic tanks on the power unit. One is the main tank and the other is a storage tank for extra oil in case the main tank becomes depleted. A hydraulic tank supplies oil to five pumps. Three pumps feed the vibrator motors. A pump feeds the clamp attachment and drill shifter. There is also a recirculation pump to keep the oil cool and filtered. The Vibrator is connected to the power unit via five hydraulic hoses. The two 2" (ID) hoses are the pressure line and the return line for the vibrator motors. Two 3/8" (ID) hoses are for the clamp system. The 1-1/4" (ID) hose is for the vibrator motors case drain line. The hoses are attached to the power unit by connecting the "quick disconnect fittings" on the end of the hoses leading from the vibrator. The fittings go on only one way so there is no chance of hooking up the hoses improperly.

WARNING: Clean with ether or a clean rag before installing quick disconnects. Make sure you seat the quick disconnect fittings all the way tight. Failure to tighten the quick disconnects will stop the flow of oil and will prevent the vibro from operating. Failure to tighten the clamp fittings completely tight will cause the jaws to either not open or not close. If this happens you may have to loosen the fitting and bleed off the pressure to release the quick disconnects.

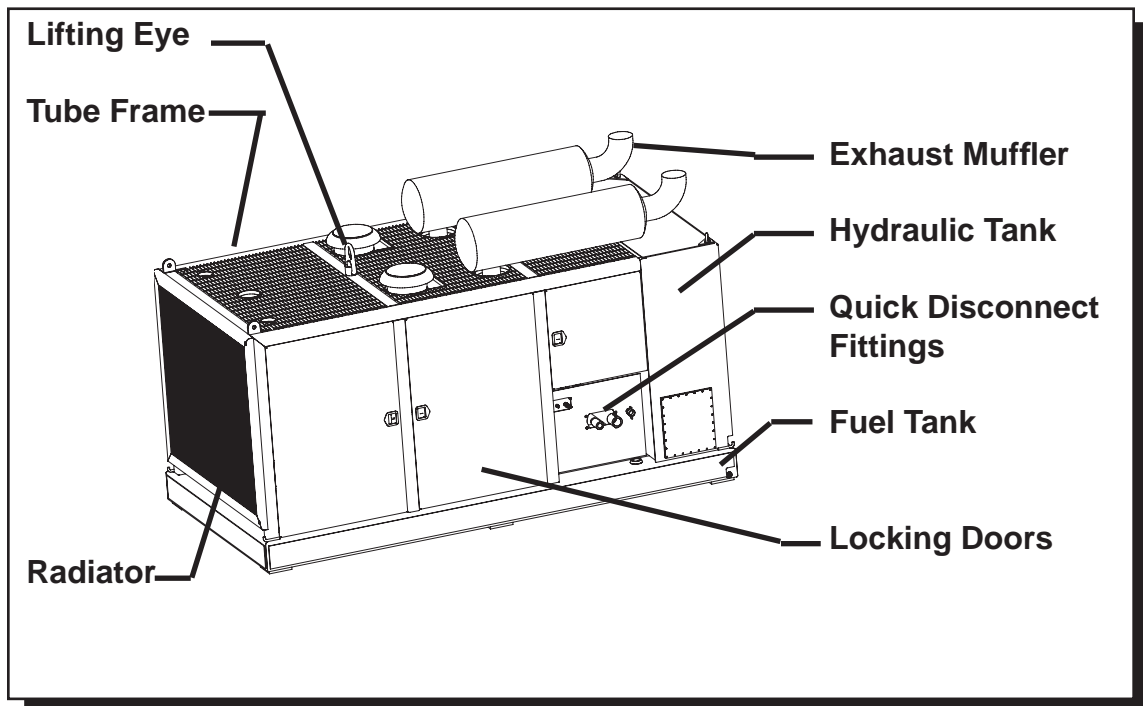

Figure 1-H. General Description of Model 1200 Power Unit

II. MAJOR COMPONENT DEFINITION

II-1. Model 400 Final Assembly Identification

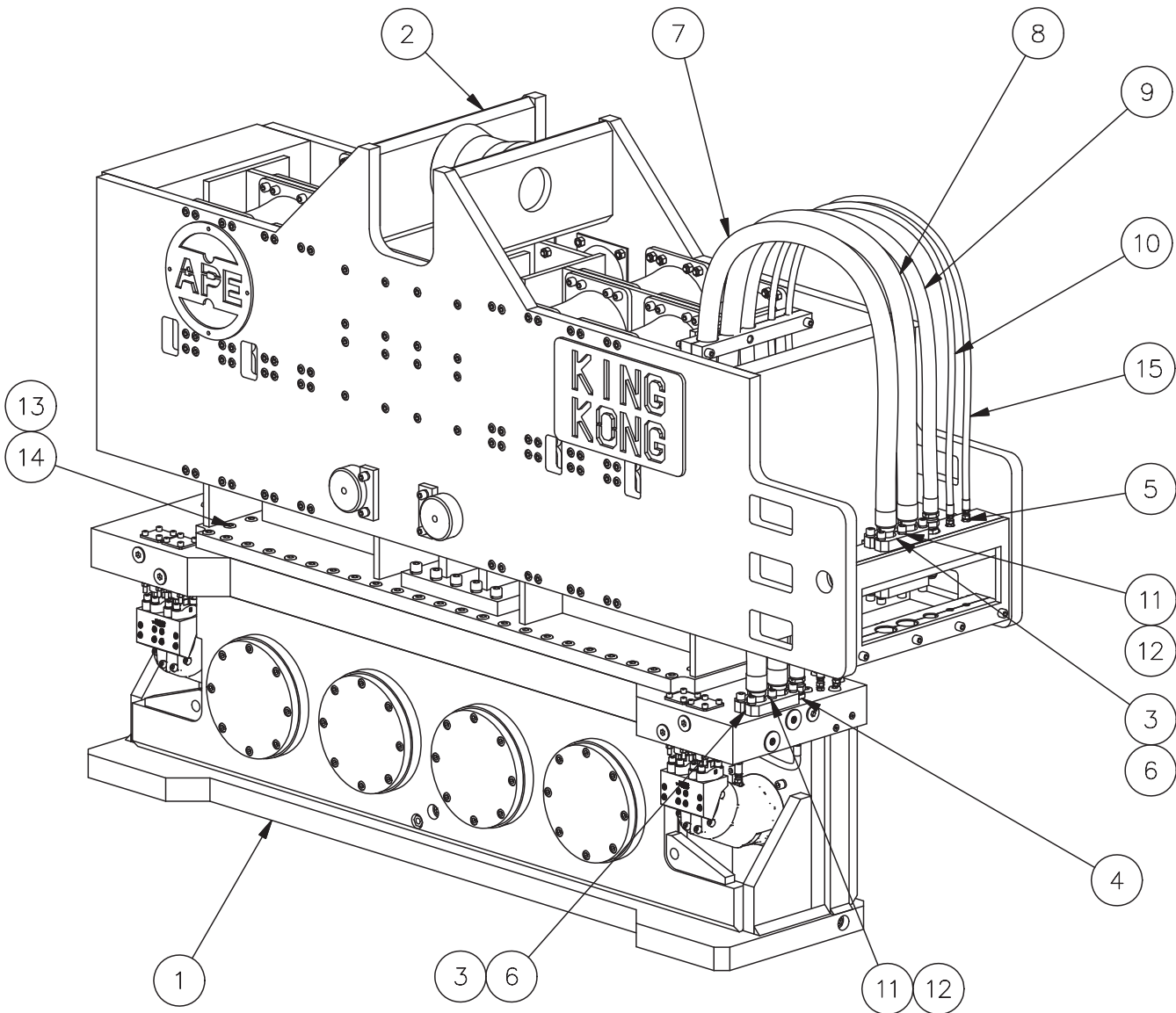

Figure 2-A. Model 400 Final Assembly



OPERATION / MAINTENANCE MANUAL

MODEL 400 VIBRATORY DRIVER WITH MODEL 1200 POWER UNIT

7032 SOUTH 196th - KENT, WA. 98032 - (253) 872-0141 / FAX (253) 872-8710

II. MAJOR COMPONENT DEFINITION

II-1. Model 400 Final Assembly Identification

ITEM	QTY	PART NUMBER	DESCRIPTION
1	1		400 GEARBOX ASM
2	1		SUPPRESSOR ASSEMBLY
3	3		GEAR BOX TOP PLATE SPLIT FLANGE
4	3	170457	FITT2S-20M20R000-0000001
5	6	130645	FITT2S-06M08R000-000H001
6	4	140223	2-228 O-RING
7	1		HOSE200R13H032H032L14400
8	1		HOSE200R13H032H032L14400
9	1		HOSE125R09J020J020L14400
10	1		HOSE038R09J006J006L14400
11	18	400727	0.75 HI COLLAR LOCK WASHER
12	18	100067	0.75-10UNC X 2.50 SHCS
13	52		1.00 HI COLLAR LOCK WASHER
14	52	300043	1.00-8UNC X 8.00 LG SHCS
15	1		HOSE038R09J006J006L14400

Table 2-A. Model 400 Final Assembly

II. MAJOR COMPONENT DEFINITION

II-2. Suppressor Identification

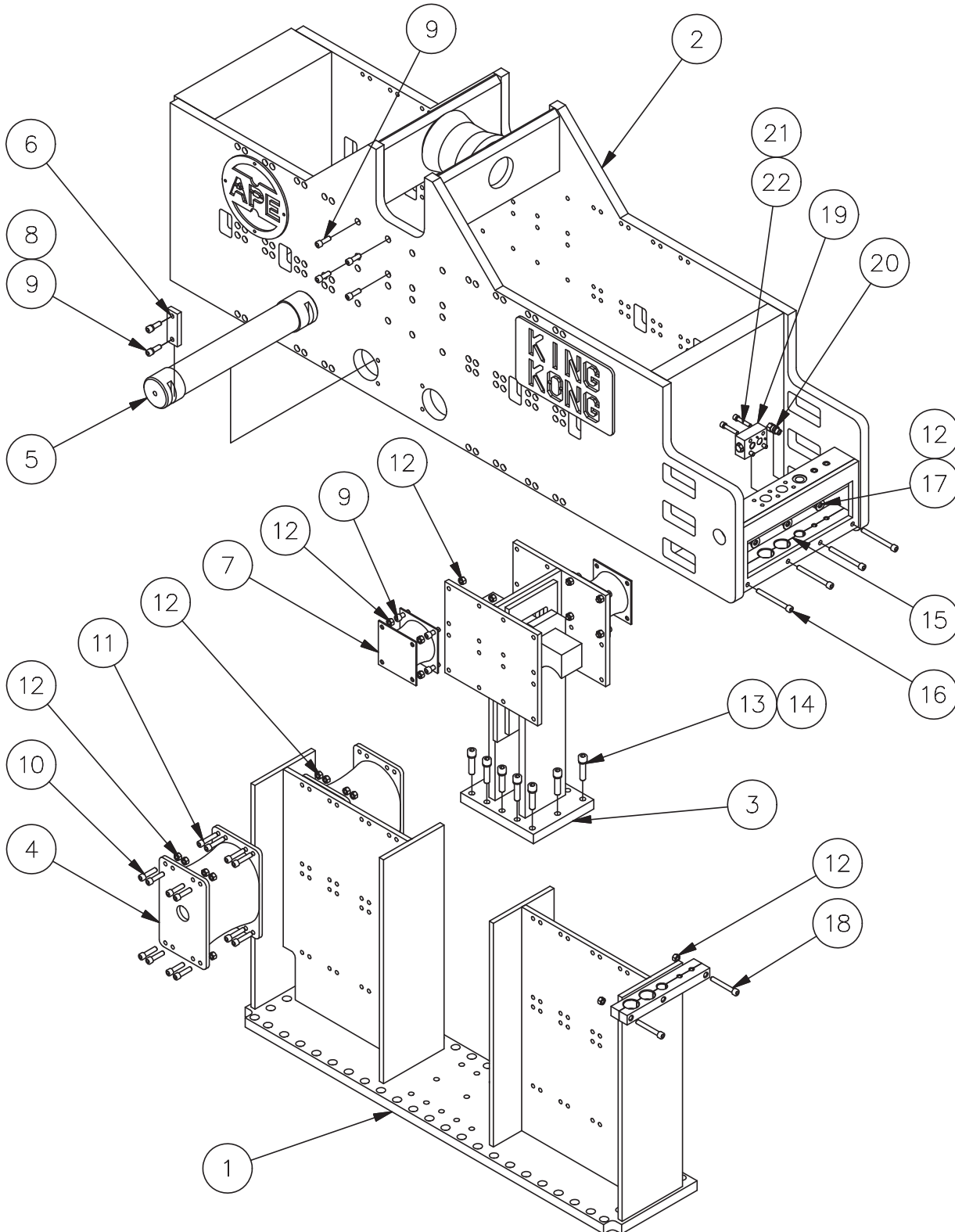

Figure 2-B. Suppressor Assembly



OPERATION / MAINTENANCE MANUAL

MODEL 400 VIBRATORY DRIVER WITH MODEL 1200 POWER UNIT

7032 SOUTH 196th - KENT, WA. 98032 - (253) 872-0141 / FAX (253) 872-8710

II. MAJOR COMPONENT DEFINITION

II-2. Suppressor Identification

ITEM	QTY	PART NUMBER	DESCRIPTION
1	1		INNER SUPPRESSOR
2	1		SUPPRESSOR HOUSING
3	1		LIFTING BRACKET
4	16	321003	LARGE ELASTOMER
5	2		SAFETY PIN
6	4		KEEPER PLATE
7	8	321004	ELASTOMER
8	8	400727	0.75 HI COLLAR LOCK WASHER
9	72		0.75-10UNC X 2.25 SHCS
10	128		0.75-10UNC X 3.00 SHCS
11	64	400045	0.75-10UNC X 3.50 SHCS
12	262		0.75-10UNC STOVER NUT
13	13		1.00 HI COLLAR LOCK WASHER
14	13	100212	1.00-8UNC X 4.00 LG SHCS
15	1		SUPPRESSOR HOSE CLAMP
16	4	160349	0.75-10UNC X 7.50 SHCS
17	4	100589	0.75 FLAT WASHER
18	2		0.75-10UNC X 5.50 SHCS
19	1	321015	CHECK VALVE ASSEMBLY
20	1	321009	POP OFF RELIEF
21	4		0.63 HI COLLAR LOCK WASHER
22	4		0.63-11UNC X 3.25 LG SHCS

Table 2-B. Suppressor Assembly

II. MAJOR COMPONENT DEFINITION

II-3. Gearbox Identification

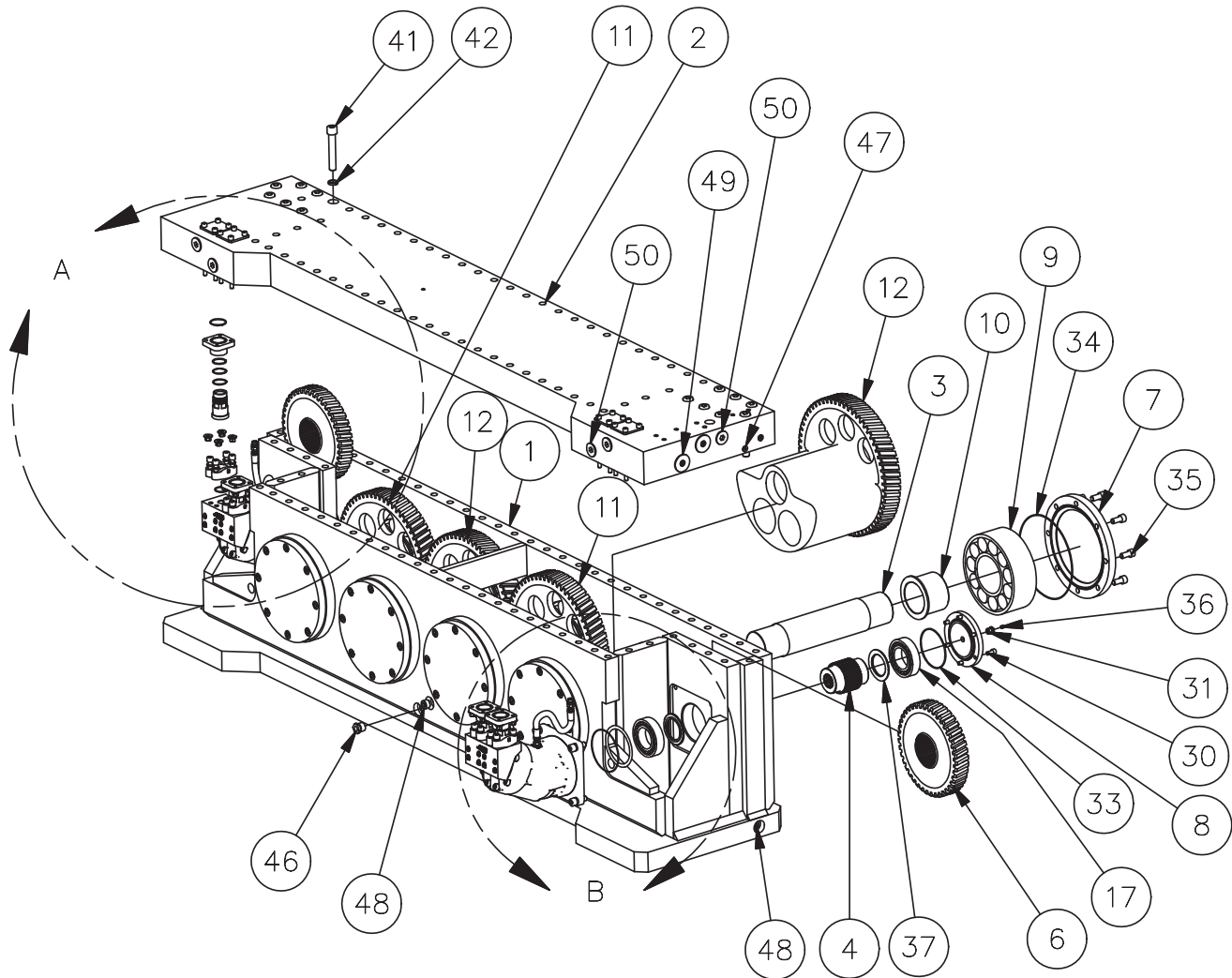

II. MAJOR COMPONENT DEFINITION

II-3. Gearbox Identification

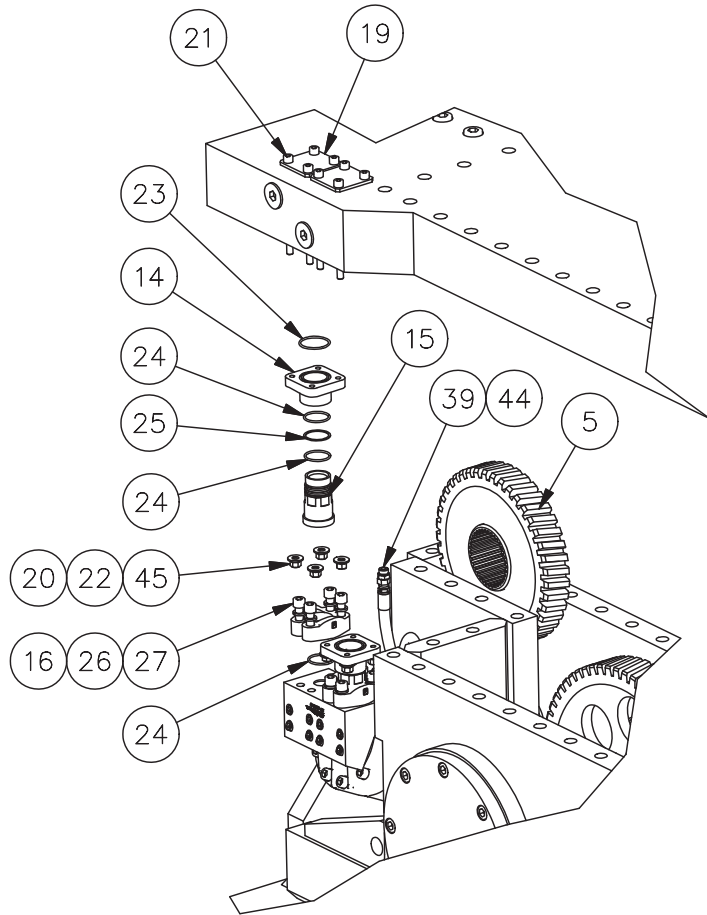

DETAIL A

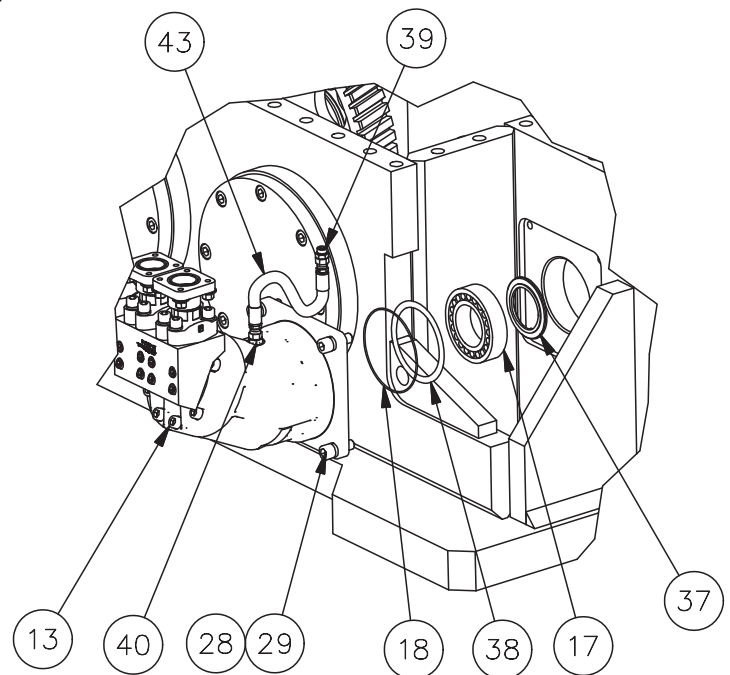

DETAIL B



OPERATION / MAINTENANCE MANUAL

MODEL 400 VIBRATORY DRIVER WITH MODEL 1200 POWER UNIT

7032 SOUTH 196th - KENT, WA. 98032 - (253) 872-0141 / FAX (253) 872-8710

II. MAJOR COMPONENT DEFINITION

II-3. Gearbox Identification

ITEM	QTY	PART NUMBER	DESCRIPTION
1	1		400 GEARBOX FRAME
2	1	143200	GEAR BOX TOP PLATE
3	4	141003	ECCENTRIC SHAFT
4	2	142010 / 142010T	GEAR CARRIER (STD. / TANDEM)
5	1	142006	DRIVE GEAR LEFT HAND
6	1	142007	DRIVE GEAR RIGHT HAND
7	8		ECCENTRIC BEARING COVER
8	2	1001767	MOTOR BEAR COVER
9	8	141001B	ECCENTRIC BEARING
10	8	141005	BEARING SLEEVE
11	2	141007F	ECCENTRIC RIGHT HAND
12	2	141007F	ECCENTRIC LEFT HAND
13	2	142001A	DRIVE MOTOR
14	4		HYD FLANGE ADAPTER
15	4		HYD MOTOR ADAPTER
16	4	110243	24 SPLIT FLANGE CODE 62
17	4	142002	MOTOR BEARING
18	2		2-165 O-RING
19	4		PLATE WASHER
20	16	100483	0.50 FLAT WASHER
21	16		0.50-13UNC X 8.00 SHCS
22	16	100121	0.50 LOCK WASHER
23	4	140223	2-228 O-RING
24	12	110119	2-225 O-RING
25	4		2-225 PAR BACK
26	16	100007	0.63 LOCK WASHER
27	16	100005	0.63-11UNC X 1.75 LG SHCS
28	8	400727	0.75 HI COLLAR LOCK WASHER
29	8	400069	0.75-10UNC X 2.00 SHCS
30	12	100445	0.50-13UNC X 1.00 SHCS
31	1	122015	GEAR BOX BREATHER
32	1		FITT2P-10R
33	2		2-258 O-RING

Table 2-C. Gearbox Assembly



OPERATION / MAINTENANCE MANUAL

MODEL 400 VIBRATORY DRIVER WITH MODEL 1200 POWER UNIT

7032 SOUTH 196th - KENT, WA. 98032 - (253) 872-0141 / FAX (253) 872-8710

II. MAJOR COMPONENT DEFINITION

II-3. Gearbox Identification

34	8		2-279 O-RING
35	64	400275	0.75-10UNC X 1.50 SHCS
36	1	100646	FITT2P-02P
37	4		GEAR SPACER
38	2		SPACER
39	2	100139	FITT2S-08M08R000-000H001
40	2	300099	FITT2S-08M10R000-000H001
41	14		1.00-8UNC X 6.00 LG SHCS
42	14		1.00 HI COLLAR LOCK WASHER
43	1		HOSE050R02J008J008L01750
44	1		HOSE050R02J008J008L01750
45	16	100485	0.50-13UNC HEX NUT
46	1	123005	SIGHT GLASS
47	4	100903	FITT2P-08R
48	3	123004	1" MAG PIPE PLUG
49	4		FITT2P-32R
50	6		FITT2P-241

Table 2-C. Gearbox Assembly



OPERATION / MAINTENANCE MANUAL

MODEL 400 VIBRATORY DRIVER WITH MODEL 1200 POWER UNIT

7032 SOUTH 196th - KENT, WA. 98032 - (253) 872-0141 / FAX (253) 872-8710

II. MAJOR COMPONENT DEFINITION

II-4. Check Valve Identification 352103

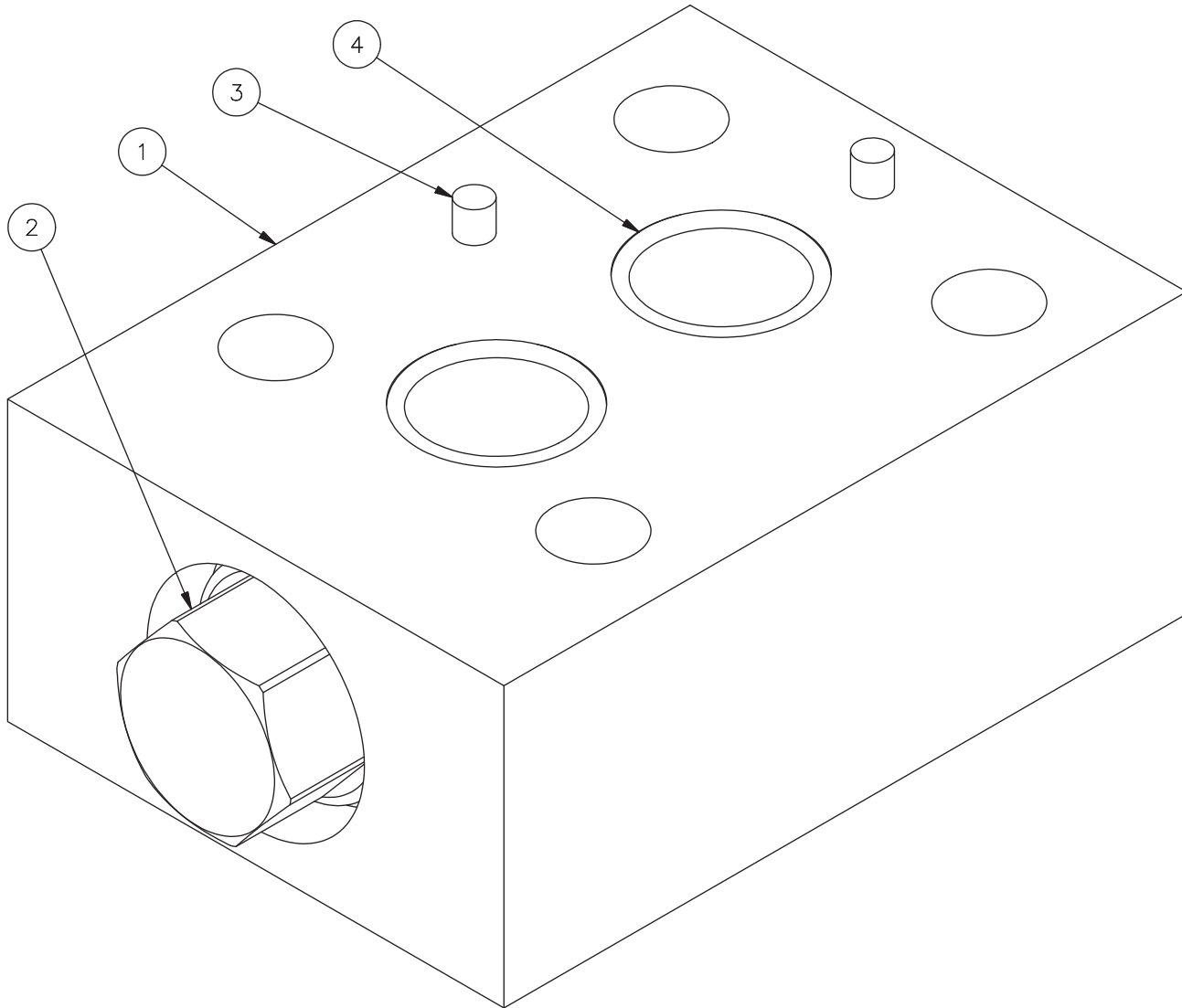

Figure 2-D. Check Valve Assembly



OPERATION / MAINTENANCE MANUAL

MODEL 400 VIBRATORY DRIVER WITH MODEL 1200 POWER UNIT

7032 SOUTH 196th - KENT, WA. 98032 - (253) 872-0141 / FAX (253) 872-8710

II. MAJOR COMPONENT DEFINITION

II-4. Check Valve Identification 352103

Parts List			
ITEM	QTY	STOCK NUMBER	DESCRIPTION
1	1		CHECK VALVE BODY
2	1		CHECK VALVE
3	2		0.25 X 0.50 LG ROLL PIN
4	2		2-121 O-RING

Table 2-D. Check Valve Assembly

II. COMPONENT DEFINITION

II-5. 196 Clamp Identification 800609

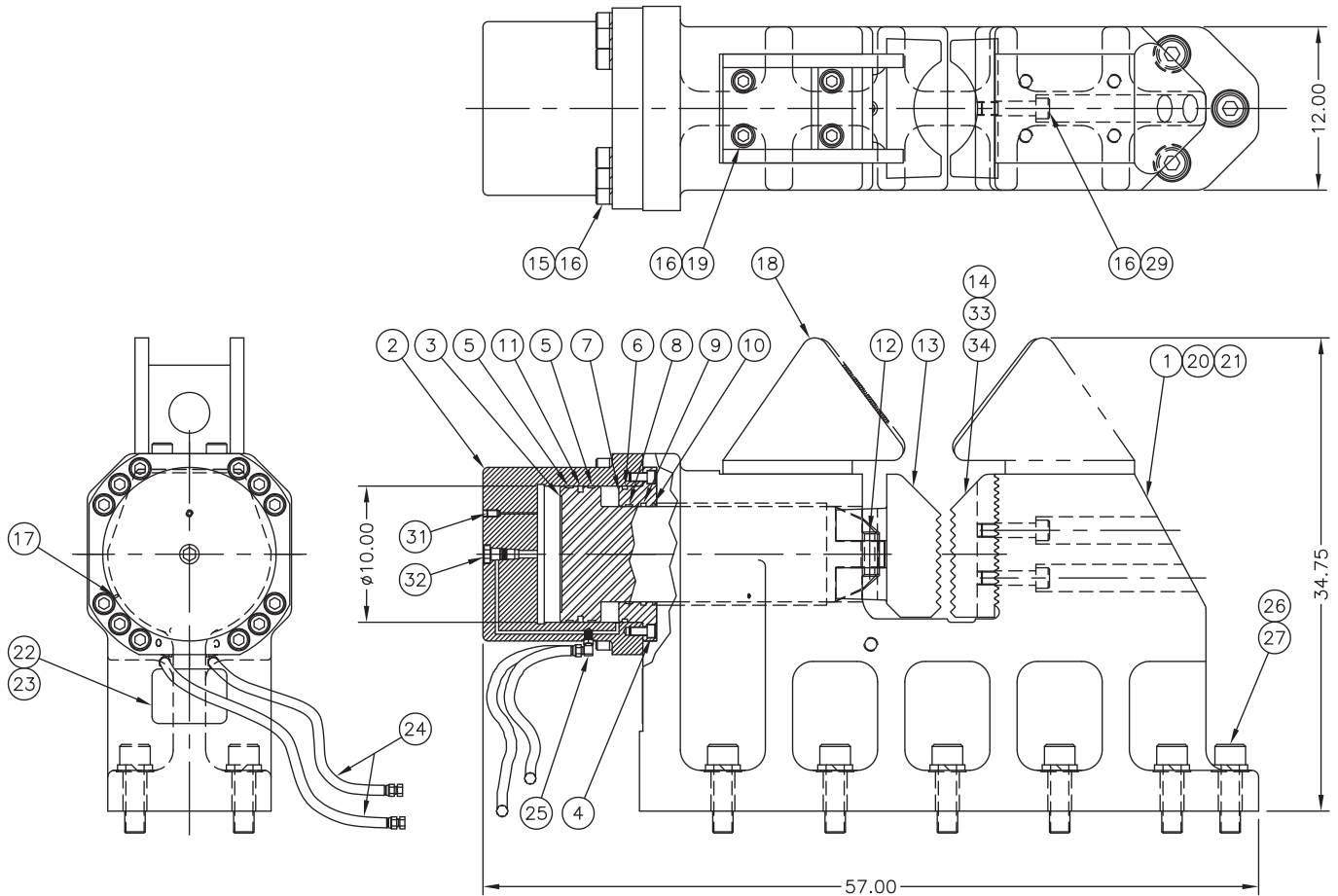

UP TO S/N 041

Figure 2-E. Model 196 Sheet Clamp Assembly



OPERATION / MAINTENANCE MANUAL

MODEL 400 VIBRATORY DRIVER WITH MODEL 1200 POWER UNIT

7032 SOUTH 196th - KENT, WA. 98032 - (253) 872-0141 / FAX (253) 872-8710

II. COMPONENT DEFINITION

II-5. 196 Clamp Identification **800609**

<u>ITEM</u>	<u>QTY</u>	<u>DESCRIPTION</u>	<u>P/N</u>
1	1	196 CLAMP CASTING ASSEMBLY	810947
2	1	196 CYLINDER	120917
3	1	196 PISTON - ROD	120913
4	12	0.625-11 UNC X 1.25 LG SHCS	100575
5	2	PISTON BEARING	120551
6	1	SEAL	120549
7	1	196 ROD END CAP	120919
8	1	ROD BEARING	120555
9	1	ROD SEAL	120553
10	1	ROD WIPER	120921
11	1	PISTON SEAL	120915
12	1	ROLL PIN .75 X 3"	130449
13	1	196 MOVEABLE JAW	810461
14	1	196 FIXED JAW	810463
15	12	1.0-8 X 3.5 LG SHCS	140145
16	18	1.00 LOCK WASHER SCHNORR	400472
17	1	GREASE FITTING	100229
18	1	PILE FEED GUIDE	100983
19	4	1.0-8 X 2.50 LG SHCS LOC WEL	100213
20	1	PRIMER/GAL	100299
21	1	APE / J&M YELLOW PAINT/GAL	100298
22	1	196 S/N PLATE	120561
23	4	RIVET	130381
24	2	HOSE038R02J006J006L132OS	120193
25	2	FITT2L-06M06R000-000H001	130057
26	11	1.5-6 X 5.0 LG SHCS	100193
27	11	1.5 LOCK WASHER EXTRA HEAVY	100195
29	2	1.0-8 X 4.00 LG SHCS LOC WEL	100212
31	1	POINTED SET SCREW	120761
32	1	HOLDING VALVE CARTRIDGE	120629
33	1	11 INCH FIXED JAW	120855
34	1	H-PILE FIXED JAW	120927

ALL SEALS ARE INCLUDED IN SEAL KIT 810473

Table 2-E. Model 196 Sheet Clamp Assembly

II. COMPONENT DEFINITION

II-6. 196 Clamp Identification 800631

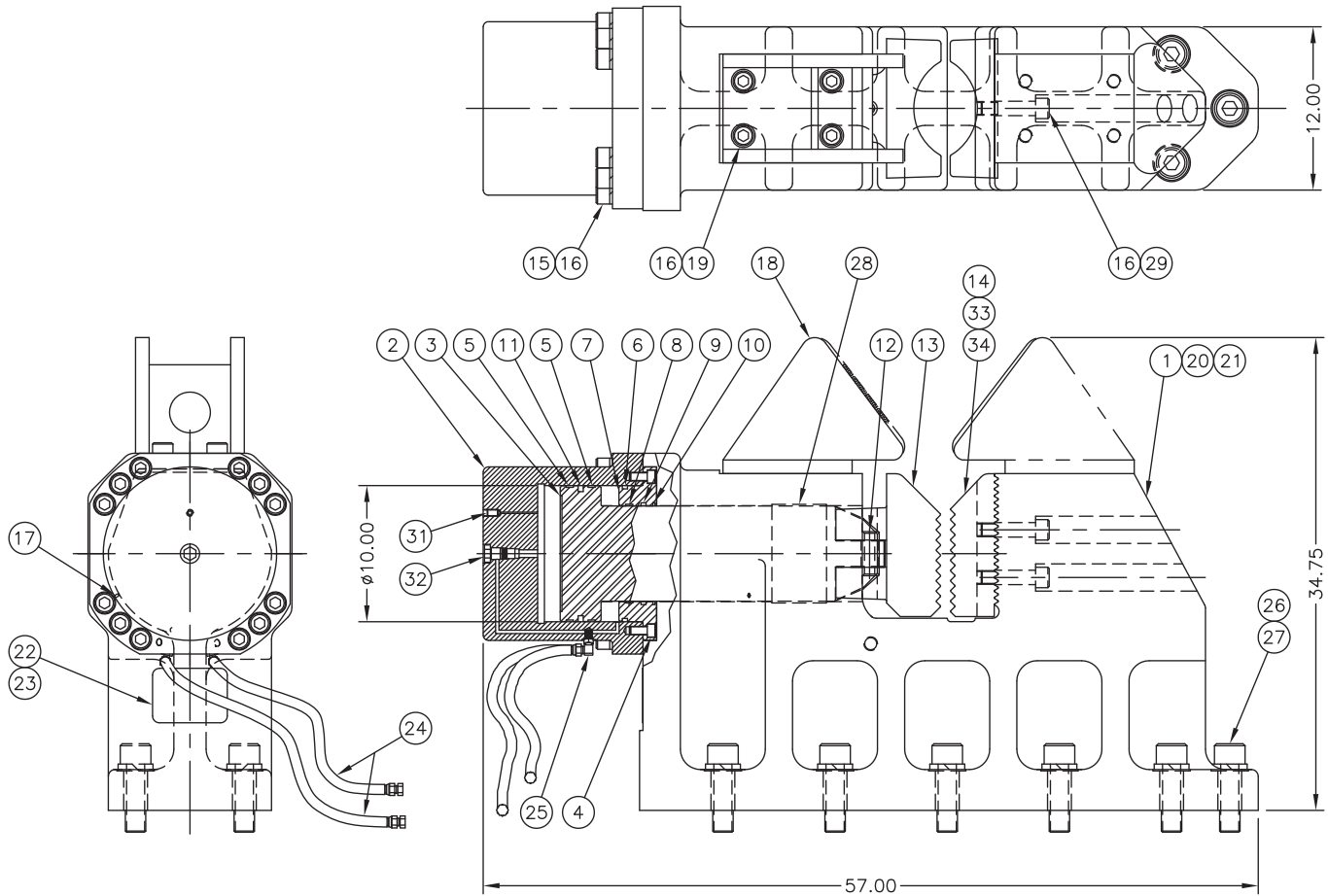

FROM S/N 042

Figure 2-F. Model 196 Sheet Clamp Assembly



OPERATION / MAINTENANCE MANUAL

MODEL 400 VIBRATORY DRIVER WITH MODEL 1200 POWER UNIT

7032 SOUTH 196th - KENT, WA. 98032 - (253) 872-0141 / FAX (253) 872-8710

II. COMPONENT DEFINITION

II-6. 196 Clamp Identification 800631

<u>ITEM</u>	<u>QTY</u>	<u>DESCRIPTION</u>	<u>P/N</u>
1	1	196 CLAMP CASTING ASSEMBLY	810947
2	1	196 CYLINDER	120917
3	1	196 PISTON - ROD	120913
4	12	0.625-11 UNC X 1.25 LG SHCS	100575
5	2	PISTON BEARING	120551
6	1	SEAL	120549
7	1	196 ROD END CAP	120919
8	1	ROD BEARING	120555
9	1	ROD SEAL	120553
10	1	ROD WIPER	120921
11	1	PISTON SEAL	120915
12	1	ROLL PIN .75 X 3"	130449
13	1	196 MOVEABLE JAW	810461
14	1	196 FIXED JAW	810463
15	12	1.0-8 X 3.5 LG SHCS	140145
16	18	1.00 LOCK WASHER SCHNORR	400472
17	1	GREASE FITTING	100229
18	1	PILE FEED GUIDE	100983
19	4	1.0-8 X 2.50 LG SHCS LOC WEL	100213
20	1	PRIMER/GAL	100299
21	1	APE / J&M YELLOW PAINT/GAL	100298
22	1	196 S/N PLATE	120561
23	4	RIVET	130381
24	2	HOSE038R02J006J006L132OS	120193
25	2	FITT2L-06M06R000-000H001	130057
26	11	1.5-6 X 5.0 LG SHCS	100193
27	11	1.5 LOCK WASHER EXTRA HEAVY	100195
28	1	ROD WEAR RING	120929
29	2	1.0-8 X 4.00 LG SHCS LOC WEL	100212
31	1	POINTED SET SCREW	120761
32	1	HOLDING VALVE CARTRIDGE	120629
33	1	11 INCH FIXED JAW	120855
34	1	H-PILE FIXED JAW	120927

ALL SEALS ARE INCLUDED IN SEAL KIT 810473

Table 2-F. Model 196 Sheet Clamp Assembly

II. COMPONENT DEFINITION

II-7. Hose Bundle

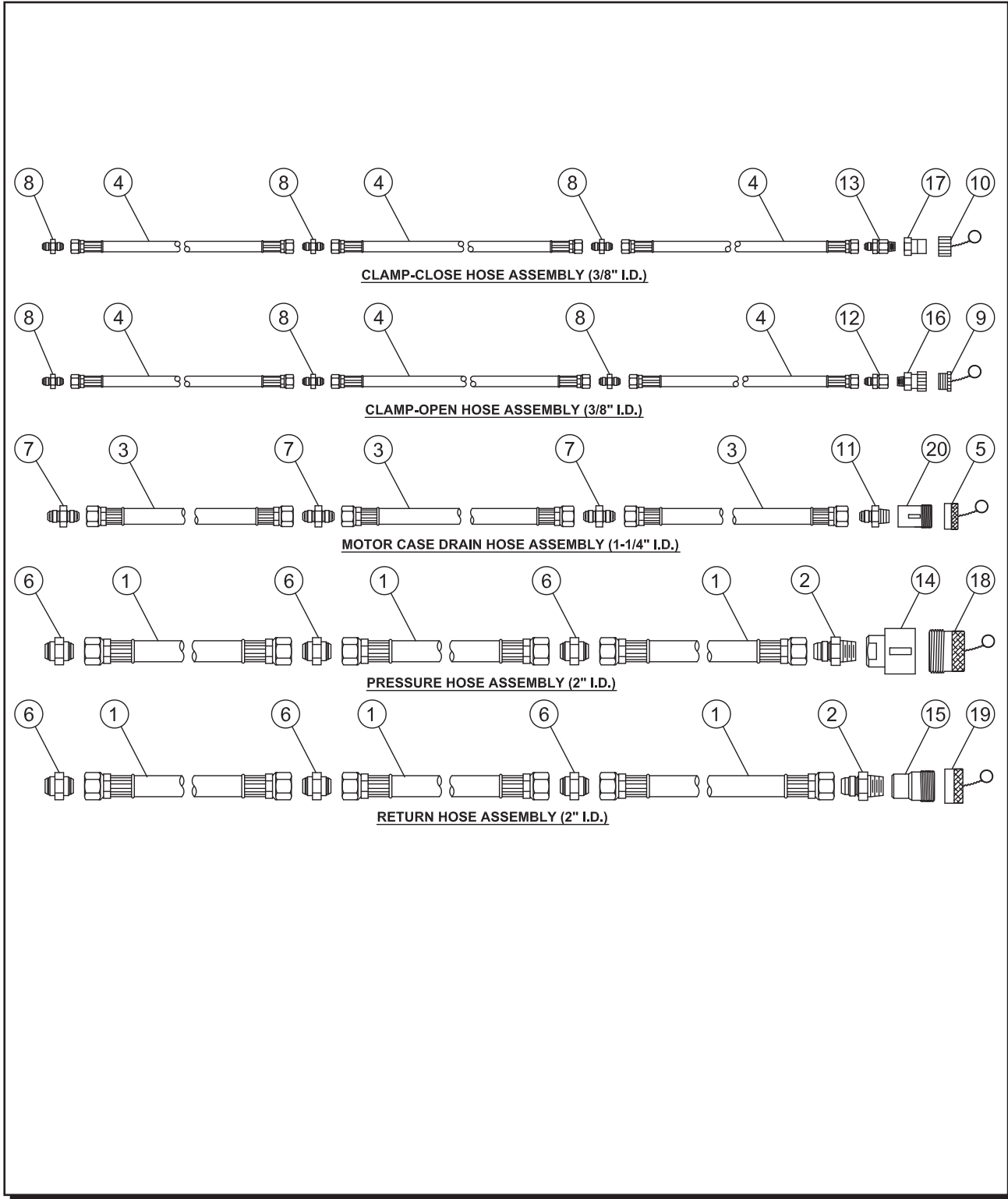

Figure 2-G. Hose Bundle



OPERATION / MAINTENANCE MANUAL

MODEL 400 VIBRATORY DRIVER WITH MODEL 1200 POWER UNIT

7032 SOUTH 196th - KENT, WA. 98032 - (253) 872-0141 / FAX (253) 872-8710

II. COMPONENT DEFINITION

II-7. Hose Bundle

The following is a general listing of the standard hoses that are shipped with the Model 400 Vibratory Driver.

Item	Qty	Description	Part No.
1	6	2" x 50' c/w 2" FJIC e/e Hose (5000 psi rated)	#421008
2	2	Fitting #32 MJIC/ #32 M.Pipe	#421051
3	3	1-1/4" x 50' c/w #20 FJIC e/e Hose (2000 psi rated)	#421009
4	6	3/8" x 50' c/w 3/8" FJIC e/e Hose (CPB 5500 psi)	#421010
5	1	1-1/4" Dust Cap	#421021
6	6	Fitting #32 Male JIC Union	#421048
7	3	Fitting #20 Male JIC Union	#440013
8	6	Fitting #6 Male JIC Union	#421014
9	1	3/8" Safeway Plug #S34-3	#421027
10	1	3/8" Safeway Cap #S39-3	#421026
11	1	Fitting #12 MJIC/ #16 M. Pipe	#555175
12	1	Fitting #6 MJIC/ #6 F. Pipe	#421011
13	1	Fitting #6 MJIC/ #6 M. Pipe	#421017
14	1	2" QD Female Coupling	#441301
15	1	2" QD. Male Coupling	#441302
16	1	3/8" Safeway Female QD #S35-3	#421024
17	1	3/8" Safeway Male QD #S31-3	#421025
18	1	APE 2" Dust Plug	#441103
19	1	APE 2" Dust Cap	#441104
20	1	1-1/4" QD Male Coupling	

Table 2-G. Hose Bundle

II. COMPONENT DEFINITION

II-8. Model 1200 Power Unit Skid Identification

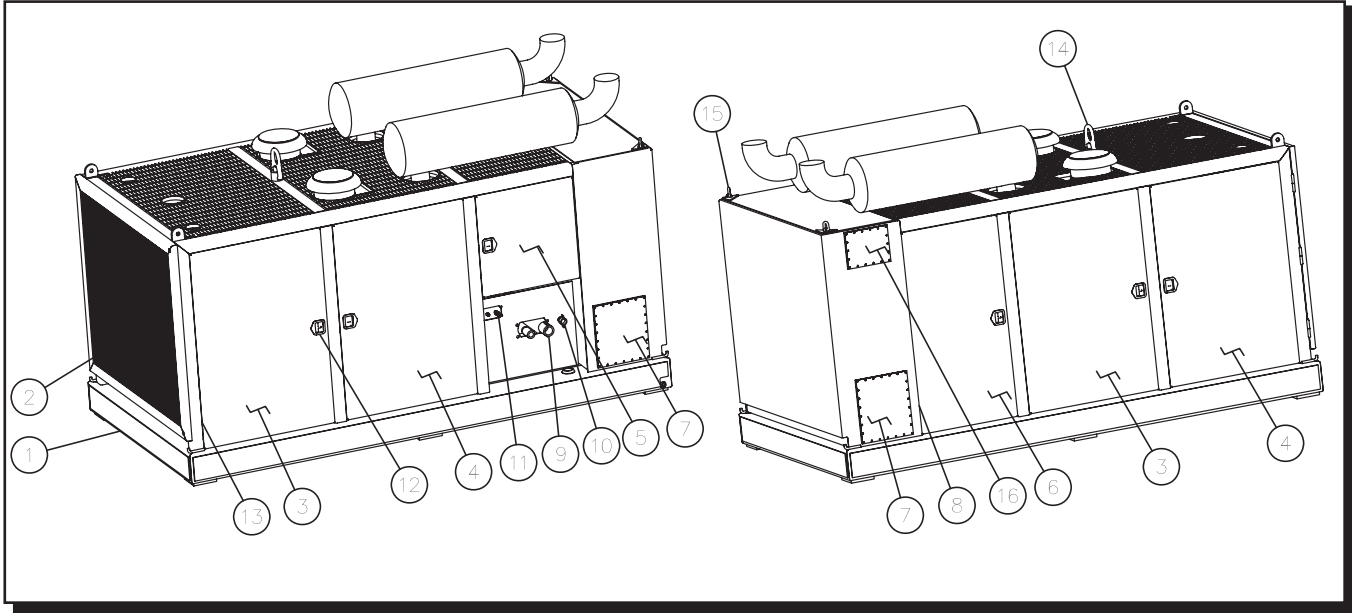

Figure 2-H. Power Unit Skid

Item	Qty	Description	Part No.
1	1	Model 1200 Power Unit Skid	
2	1	Radiator Grill	
3	2	Door 45.50" x 66.50"	
4	2	Door 45.50" x 66.50"	
5	1	Door 33.75" x 34.50"	
6	1	Door 33.75" x 66.50"	
7	2	Access Cover Plate 21" X 18"	
8	1	Access Cover Plate 15" X 12"	
9A	1	2" Hyd. Quick Disconnect Female "REV"	441301
9B	1	2" Hyd. Quick Disconnect Male "FWD"	441302
10	1	1-1/4" Hyd. Quick Disconnect Female Vibro Case Drain	
11A	1	3/8" Hyd. Quick Disconnect Female Clamp ""	421024
11B	1	3/8" Hyd. Quick Disconnect Male Clamp ""	421025
11C	1	3/8" Hyd. Quick Disconnect Male Drill Shift	555155
12	5	Dead Bolt Latch Allegis P/N 105ES SS 48 T- Handle-Allegis P/N 4874 SS	
13	15	Hinges #FES 150 GF Weld On Hinge	
14	2	Lifting Eye Crosby #1068062	
15	2	Lifting Lug Gunnebo # WLP-3T	

Table 2-H. Power Unit Skid



OPERATION / MAINTENANCE MANUAL

MODEL 400 VIBRATORY DRIVER WITH MODEL 1200 POWER UNIT

7032 SOUTH 196th - KENT, WA. 98032 - (253) 872-0141 / FAX (253) 872-8710

II. MAJOR COMPONENT DEFINITION

II-9. 2" Quick Disconnect Coupling Identification

The APE 2 Inch Quick Disconnect Couplings are high pressure hydraulic couplings designed for rugged applications. Service in many such applications has proven the design compatible to extreme pressures, structural and system induced shock loads. The construction of the coupling assembly promotes ease of use and maintenance.

Design Features:

- Excellent flow characteristics for continuous duty applications.
- High strength design endures high surge and shock conditions.
- Flat crested stub-ACME threads and all steel construction withstand storage and rig-up damage.
- Structurally compatible with weight of 5,000 P.S.I. flex-hose and system induced shock loads.

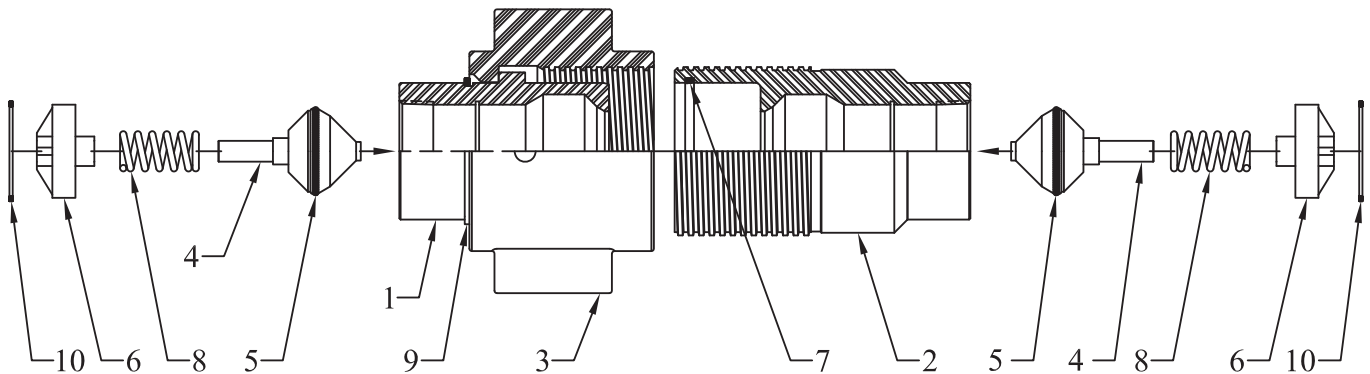

Figure 2-I. 2" Quick Disconnect Coupling

Item	Qty	Description
1	1	Hydraulic Female Coupling
2	1	Hydraulic Male Coupling
3	1	Hydraulic Female Sleeve
4	2	Poppet Valve
5	2	Parker O-Ring #2-
6	2	Plunger
7	2	Parker O-Ring & One Parback
8	2	Poppet Valve / Plunger Spring
9	1	Retaining Ring
10	2	Retaining Ring - "Truarc Internal"

Table 2-I. 2" Quick Disconnect Coupling

Quick Disconnect Assem.	# 441100
Dust Plug	# 441103
Dust Cap	# 441104
Complete Seal Kit	# 441102a
Rebuild Kit (Includes Seal Kit)	# 441706

II. MAJOR COMPONENT DEFINITION

II-10. 200 Caisson Clamp Identification

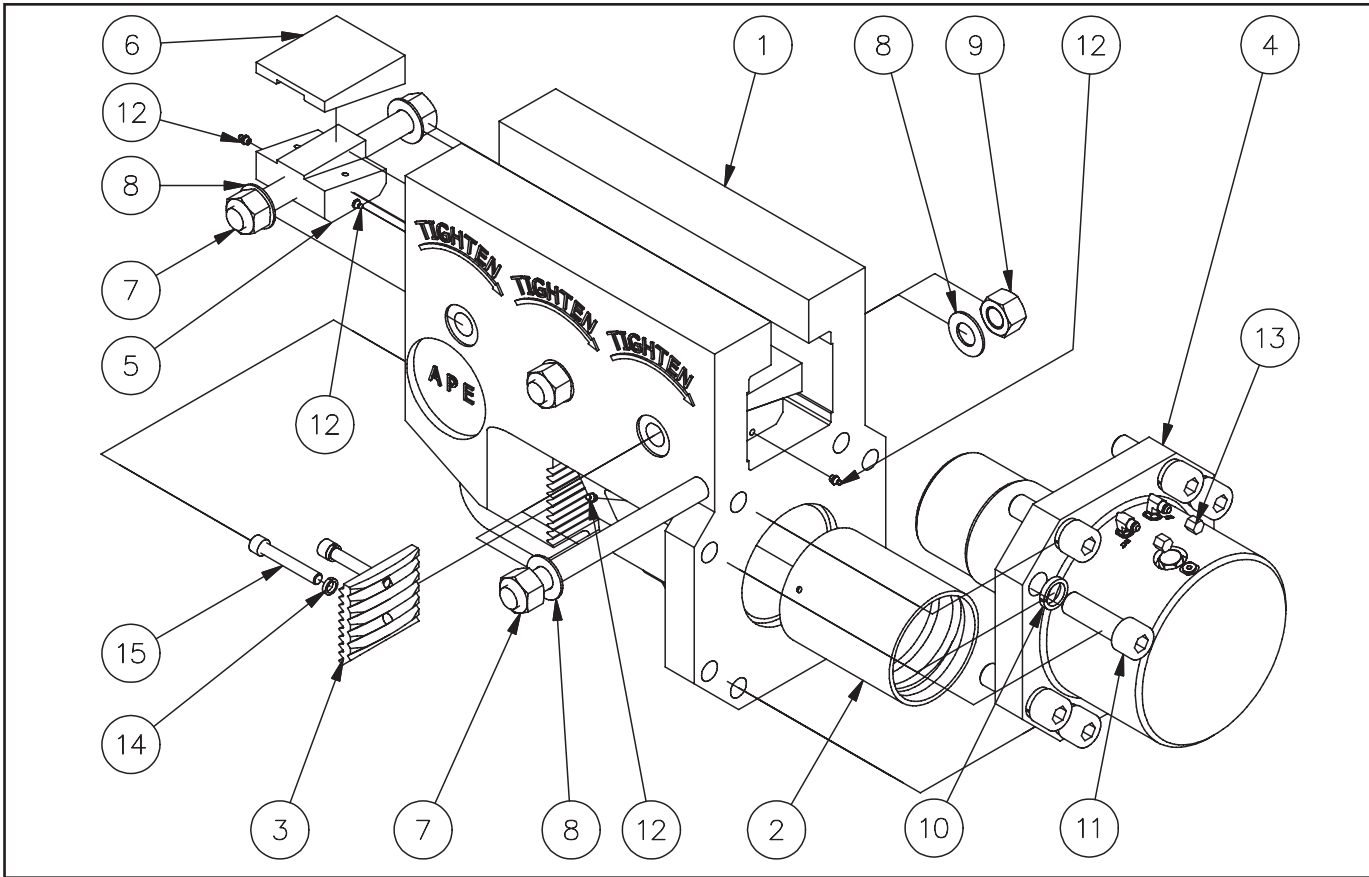

Figure 2-J. 200 Caisson Clamp Assembly

Item	Qty	Description	Part #
1	1	Caisson Clamp Body	#250101
2	1	Plastic Sleeve	#250224
3	1	Fixed Jaw	#250202H
4	1	Clamp Cylinder Asm	#251001
5	3	Male Wedge Half (Bronze)	#243102
6	3	Female Wedge Half (Steel)	#243105
7	3	ACME Wedge Bolt	#124211A
8	6	Wedge Washer	#124219
9	3	ACME Wedge Nut	#124122
10	8	1-1/4" High Collar Lock Washer	#124205
11	8	Bolt - SHCS 1-1/4" NF x 4.00	#124204
12	7	Grease Zerk	#221001
13	2	#6 JIC Cap BRE304C6	#100057
14	2	Lock Washer 5/8" High Collar	#124115
15	2	Bolt - SHCS 5/8" x 4"	#124214

II. MAJOR COMPONENT DEFINITION

II-11. 200 Caisson Clamp Cylinder Identification

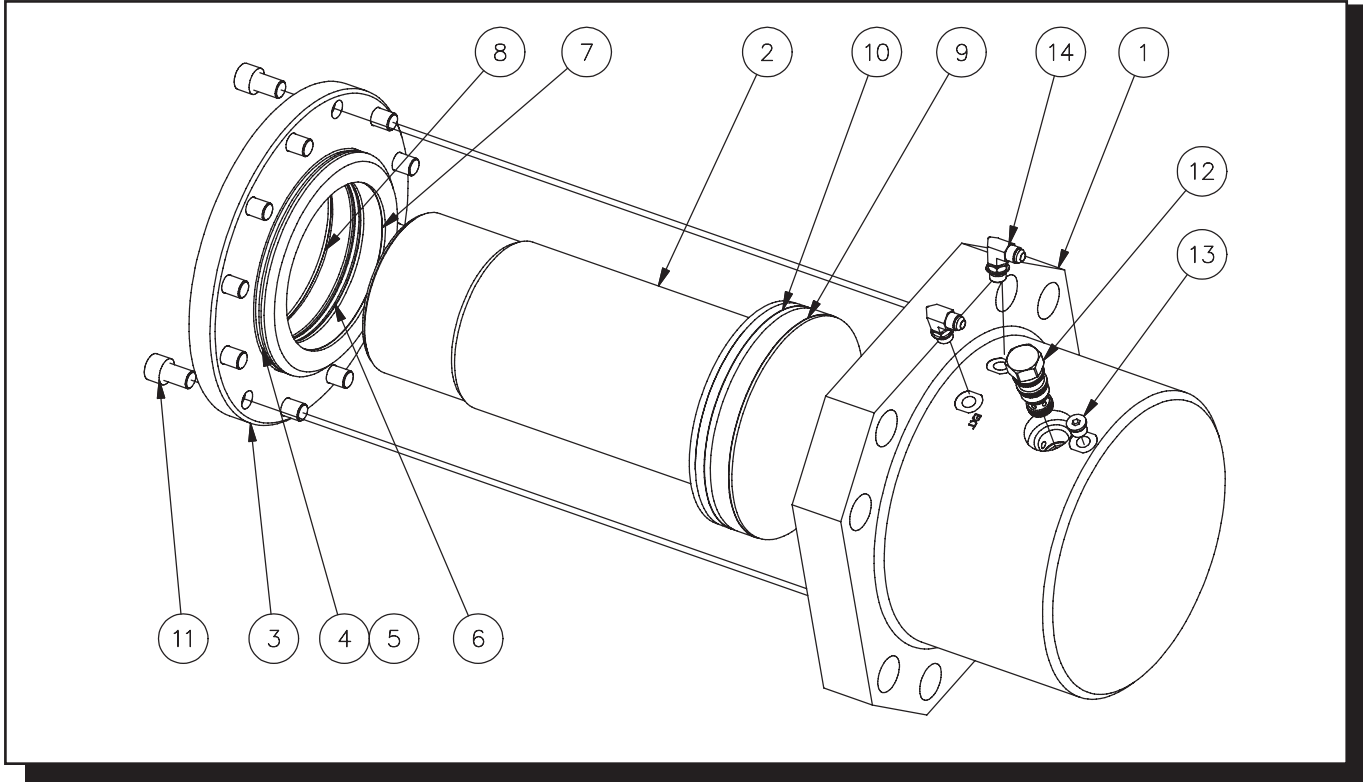

Figure 2-K. 200 Caisson Clamp Cylinder Assembly #250001

Item	Qty	Description	Part #
1	1	Clamp Cylinder Bucket	#1001409
2	1	Piston Rod	#250003
3	1	Cylinder Gland	#222004
4	1	*O-Ring 2-367	
5	1	*8-367 Par Bak	
6	1	*Rod Seal	
7	1	*Rod Wear Band	
8	1	*Rod Wiper	
9	1	*Piston Wear Band	
10	1	*Piston Ring and Expander	
11	12	Bolt SHCS 0.625-18UNF X 1.00	#1003804
12	1	P O Check Valve CKEB-XCN	#222016
13	1	#6 SAE Allen Plug	#1003959
14	2	#6 M O-Ring - #6 M JIC 90 deg Fitting	#130057

*Included in Seal Kit-8" Clamp Cylinder #1003614

Table 2-J. 200 Caisson Clamp Cylinder Assembly

II. MAJOR COMPONENT DEFINITION

II-12. Control Panel

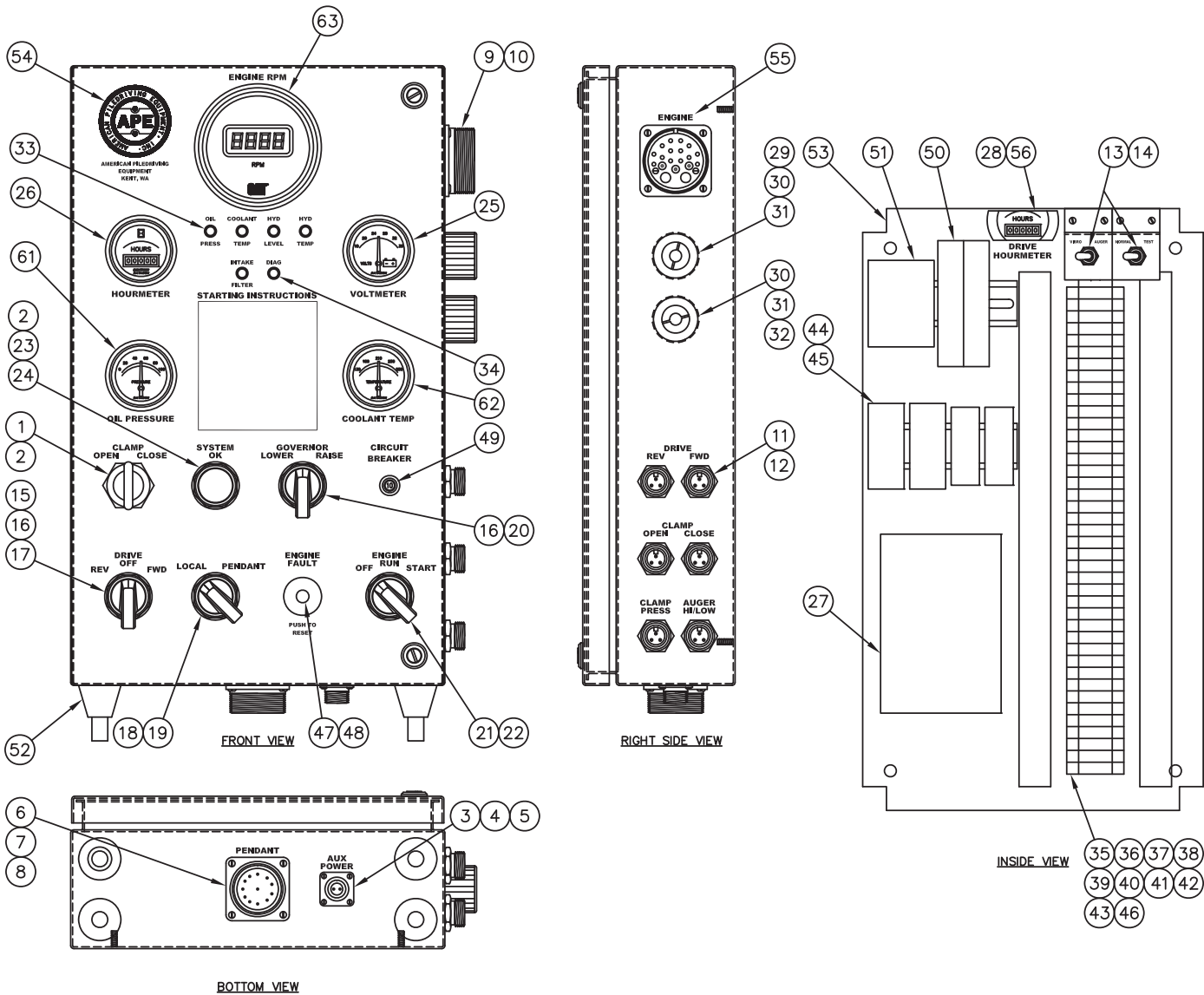

Figure 2-L. Control Panel Assembly

Items not shown: 57, 58, 59, 60



OPERATION / MAINTENANCE MANUAL

MODEL 400 VIBRATORY DRIVER WITH MODEL 1200 POWER UNIT

7032 SOUTH 196th - KENT, WA. 98032 - (253) 872-0141 / FAX (253) 872-8710

II. MAJOR COMPONENT DEFINITION

II-12. Control Panel

ITEM	DESCRIPTION	QTY	PART BREAKDOWN	MFG.	MFG. PART #
1	Lighted Clmp. Open/Cl. Sw.	1	Illuminated 3-Pos. Spr. Ret. from L	Brad Harrison	800T-24JG4KB7AX
2	Green L.E.D.	2	Green L.E.D.	Brad Harrison	LSTD-2G
3	Auxiliary Pwr. Receptacle	1	PM 2-socket Aux. Receptacle	Amphenol	MS3102A-12S-3-S
4		1	PM Aux Receptacle Gasket	Amphenol	10-40450-12
5		1	PM Aux Receptacle Cover	Amphenol	MS25043-12D
6	Pendant Receptacle	1	PM 15 Socket Pendant Receptacle	Amphenol	MS3102A28-17S
7		1	PM Pen Receptacle Gasket	Amphenol	10-40450-28
8		1	PM Pen Receptacle Cover	Amphenol	MS25043-28D
9	Engine Receptacle	1	PM 23-Pin Engine Receptacle Amphenol	Amphenol	MS3102A32-6P
10		1	PM Engine Receptacle Gasket	Amphenol	10-40450-32
11	PM S.O. Cord Hookups	6	Side PM Male Receptacle	Brad Harrison	1R3006A24A120
12		6	1/2" Lock Nut	Regal	801
13	Vibro / Auger - Test	2	Toggle Switch 2 position	CPI	10011
14	Switch Bracket	2	SS Small Z Bracket	CPI	18200
15	Drive Rev/Fwd Switch	1	3-Position Operator (Maint.)	C-H	10250T3023
16		2	Contact Block, 2 N.O.	C-H	10250T2
17		1	Contact Block, 2 N.C.	C-H	10250T3
18	Local/Pendant Switch	1	2-Position Operator (Maint.)	C-H	10250T3011
19		2	Contact Block, 2 N.O. / 2 N.C. C-H	C-H	10250T44
20	Governor Lower/Raise Sw.	1	3-Position Operator (Mom.)	C-H	10250T3043
21	Engine Control Switch	1	3-Position Operator (Maint/Mom)	C-H	10250T3053
22		1	Contact Block	C-H	10250T1
23	Lampholder	1	System O.K. Lampholder	C-H	10250T206N
24	Green Lens	1	Green Lens	C-H	10250TC2N
25	Volt Meter Gauge	1	Volt Meter Gauge	Datcon	100165
26	HourMeter Gauge	1	HourMeter Gauge	Datcon	100223
27	Speed Switch	1	Speed Switch	ECU	ECU-SS40
28	Drive Hour Meter Bracket	1	Drive Hour Meter Bracket	Hobbs	23944
29	Cord Connector	1	3/4"-3/8"-1/2" Cord Connector	Hubbell	SHC1035CR
30		2	3/4" Lock Nut	Regal	802
31		2	3/4" Rubber Gasket	T&B	5303
32	Cord Connector	1	3/4" Cord Connector	Hubbell	SHC1036CR
33	Panel Alarm Lights	5	Red L.E.D.	Idec	AP8M222-R
34	Diagnosis	1	Amber L.E.D.	Idec	AP8M222-A
35	Panel Terminal Blocks	41	Terminal Block	Idec	BNH15MW
36		4	Terminal Block	Idec	BNH30W
37		1	Terminal End Section	Idec	BNE15W
38		1	Terminal End Section	Idec	BNE30W
39		4	Terminal End Clamp	Idec	BNL5
40		1	Strip Clear Terminal Block Cover	Idec	BNC230PN10
41		2	Metal Jumper	Idec	BNJ26FW
42		1	Terminal Block Number Strip	Idec	BNM7PN10
43		1	Number Strip Holder	Idec	BNM3

Table 2-L. Control Panel Assembly



OPERATION / MAINTENANCE MANUAL

MODEL 400 VIBRATORY DRIVER WITH MODEL 1200 POWER UNIT

7032 SOUTH 196th - KENT, WA. 98032 - (253) 872-0141 / FAX (253) 872-8710

II. MAJOR COMPONENT DEFINITION

II-12. Control Panel (Continued...)

ITEM	DESCRIPTION	QTY	PART BREAKDOWN	MFG.	MFG. PART #
44	2 Pole Relay	2	Lighted Relay, DPDT	Idec	RH2BUL-24VDC
45		2	Relay Base, 2 Pole	Idec	SH2B-05C
46	Diode	15	Diode, 6 Amp	Idec	60S6
47	Engine Fault Switch	1	Magnetic Switch	Murphy	117PH
48	Dust Cover	1	Clear Dust Cover	Murphy	250547
49	10 Amp Circuit Breaker	1	Circuit Breaker, 10 Amp	P&B	W58-XC4C12A-10
50	16 Amp Circuit Breaker	1	Circuit Breaker, 16 Amp	P&B	5SX2116-8
51	Tachometer Transducer	1	Tachometer Transducer	Red Lion	IFMA0035
52	Rubber Stand Offs	4	Shock Mount Legs (1/4")	Vib. Elim.	40B
53	SS Enclosure Back Pan	1	SS Enclosure Back Pan	Vulcan	Stainless
54	SS Door Silk Screen	1	Door Silk Screen CPI	3700S116	
55	S.O. Cord Description	1	Side Legend Plates	CPI	3700SP40
56	Drive Rev/Fwd Hourmeter	1	Drive Hourmeter	Hobbs	85094-12
57	4 M Yellow S.O. Cord	3	4 M Yellow S.O. Cord	Brad Harrison	103000A02F120
58	8 M Yellow S.O. Cord	2	8 M Yellow S.O. Cord	Brad Harrison	103000A02F250
59	6 M Double-Ended S.O. Cord	1	6 M Double-Ended S.O. Cord	Brad Harrison	113022A01F200
60	Shock Mount Foot	2	Shock Mount Foot	Vib. Elim.	T22-3
61	Oil Pressure Gauge	1	Oil Pressure Gauge	Murphy	20P100
62	Coolant Temperature Gauge	1	Water Temperature Gauge	Murphy	20T25010
63	Engine RPM Gauge	1	Engine RPM Gauge	Caterpillar	197-7348

Table 2-L. Control Panel Assembly (Continued...)

II. MAJOR COMPONENT DEFINITION

II-13. Control Panel Gages

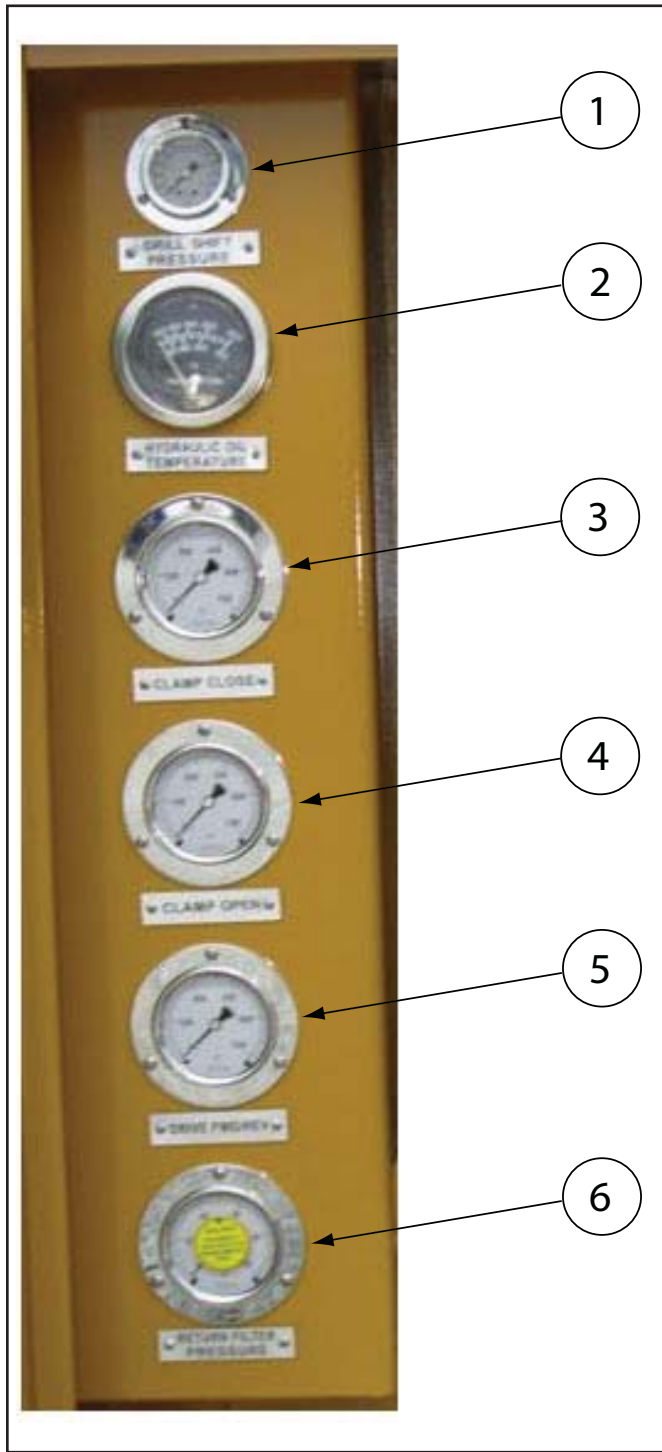

ITEM	APE P/N
1. DRILL SHIFT PRESS.	555051
2. OIL TEMP. GAGE	523016
3. CLAMP CLOSE GAGE	513007
4. CLAMP OPEN GAGE	513007
5. DRIVE GAGE	513007
6. RET. FILTER PRESS.	513007A

Table 2-M. Control Panel-Gages.

Figure 2-M. Control Panel Gages

II. MAJOR COMPONENT DEFINITION

II-14. Control Pendant

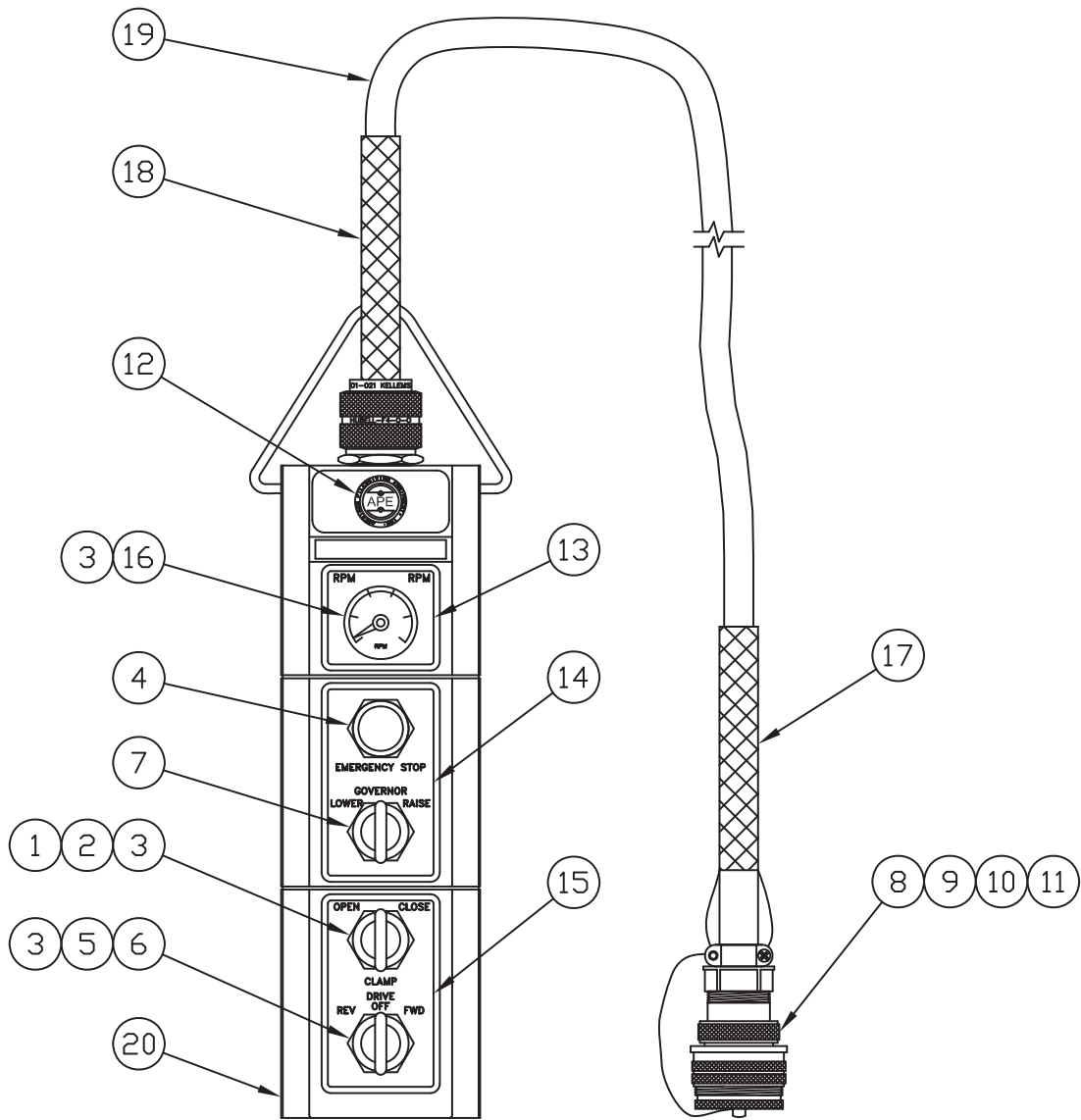

Figure 2-N. Control Pendant Assembly



OPERATION / MAINTENANCE MANUAL

MODEL 400 VIBRATORY DRIVER WITH MODEL 1200 POWER UNIT

7032 SOUTH 196th - KENT, WA. 98032 - (253) 872-0141 / FAX (253) 872-8710

II. MAJOR COMPONENT DEFINITION

II-14. Control Pendant

Item #	QTY.	DESCRIPTION	PART DESCRIPTION	MFG.	MFG. PART #
1	1	Illum. 3 Pos. Spr Ret From L	Clamp Open/Close Sw.	A-B	800T-24JG4KB7AX
2	2	Green L.E.D.	Green L.E.D.	Brad Harrison	LSTD-2G
3	4	Diode	Diode	I/R	60S6
4	1	Flush Head Red PB 1 n.o.	Emergency Stop PB	A-B	800T-A6D1
5	1	3 Pos. Maintained Switch	Drive Rev/Fwd Switch	A-B	800T-J2KC1
6	1	Contact Block 1N.O./N.C.	Contact Block, 1N.O./N.C.	A-B	800T-XA
7	1	3 Pos. Spr. Ret. From Both	Governor Lower/Raise Sw.	A-B	800T-J91A
8	1	Pendant 12 Pin Plug	CM 12 Pin Plug	Amphenol	MS3106A28-18P
9	1	Pendant Plug Clamp	CM Pendant Plug Clamp	Amphenol	MS3057-16A
10	1	Cable Rubber Insert	Clamp Rubber Insert	Amphenol	MS3420-12
11	1	Pendant Plug Cover	CM Pen Plug Cover	Amphenol	MS25042-28D
12	1	A.P.E	Pendant Decal	CPI	NP01
13	1	Engine RPM	Pendant Decal	CPI	NP03
14	1	E/Stop-Lower/Raise	Pendant Decal	CPI	NP04
15	1	Open/Close-Rev/Fwd	Pendant Decal	CPI	NP05
16	1	Analog Meter 0-2500 rpm	RPM Gauge	Crompton	082-80R2-215256
17	1	Kellems Cord Grip	Deluxe Cord Grip	Hubbell	073-10-003
18	1	Deluxe Cord Grip	Pendant Mount Cord Grip	Hubbell	074-01-017
19	50	16 Awg 14 Con. Pend. Cbl.	16 Awg 14 Con. Pend. Cbl.	Perfaflex	F19061614
20	1	4 Unit Pendant Box	Pendant Station 4 Hole	Square-D	9001-SKYP-4

Table 2-N. Control Pendant Assembly



OPERATION / MAINTENANCE MANUAL

MODEL 400 VIBRATORY DRIVER WITH MODEL 1200 POWER UNIT

7032 SOUTH 196th - KENT, WA. 98032 - (253) 872-0141 / FAX (253) 872-8710



OPERATION / MAINTENANCE MANUAL

MODEL 400 VIBRATORY DRIVER WITH MODEL 1200 POWER UNIT

7032 SOUTH 196th - KENT, WA. 98032 - (253) 872-0141 / FAX (253) 872-8710

III. LOADING AND UNLOADING

III-1. Model 400 Vibratory Driver

The APE 400 vibrator is normally shipped in a travel stand. Two sliding pins release the vibrator from the stand. To re-install, set vibro in stand and slide pins inward and rotate. Hoist vibro and stand by rigging to the vibro lifting shackle. Vibrator shipped without stands is usually laid flat on the trailer deck and the hose bundle is coiled on top. Lift the vibrator by rigging one line to the lifting shackle and one line around the clamp attachment lifting the vibro and hose bundle as one load. Avoid smashing hydraulic lines. Vibro should be loaded with hydraulic motors down facing the deck and breather valves facing the sky. Before the truck has left, carefully inspect the machine and hoses for any missing equipment or sign of damage that may have occurred during shipment or unloading.

III-2. Model 1200 Power Unit

The Power Unit is always loaded with the oil cooler / radiator facing to the rear of the truck to prevent damage to the cooler and the radiator from flying objects. The Power Unit is usually held to the truck by wrapping a chain around both ends of the fuel tank base and the truck bed. After loading the Power Unit, tape the exhaust rain cap shut to prevent rain water from getting inside. If quick disconnects do not have safety cables then store them under the panel in the storage box rather than risk the possibility of the caps and plugs coming loose and falling off into traffic. Make sure all doors are fully closed. Tighten fuel vent on the fuel cap to prevent diesel fuel from washing out the fill spout.

III-3. What to do if damaged during shipment

In the event of damage, notify the trucking agent at once. Note all damage on the bill of lading. Fax the information as soon as possible, any delay may make it impossible to find the responsible party.



OPERATION / MAINTENANCE MANUAL

MODEL 400 VIBRATORY DRIVER WITH MODEL 1200 POWER UNIT

7032 SOUTH 196th - KENT, WA. 98032 - (253) 872-0141 / FAX (253) 872-8710



OPERATION / MAINTENANCE MANUAL

MODEL 400 VIBRATORY DRIVER WITH MODEL 1200 POWER UNIT

7032 SOUTH 196th - KENT, WA. 98032 - (253) 872-0141 / FAX (253) 872-8710

IV. PREPARATION AND OPERATION

IV-1. Rigging of Vibratory Driver

A steel wire rope sling must be connected to the lifting bail located on top of the vibro. The required strength of this sling depends on the capacity of the crane and the work to be carried out. A safety factor of six is recommended. Several turns of a smaller diameter cable will result in a longer lasting sling than one larger diameter cable. When making a sling, avoid using cheap cable clamps. Check the clamps daily.

IV-2. Installing the Clamp Attachment

The Vibro is fitted with a standard sheet clamp at the factory. However, several types of clamps are used on APE vibros to fit many different types of piles. A step by step procedure is provided as follows:

- 1.) Clean all drilled and tapped threads on the bottom surface of the gearbox. Use a 1 1/2"UNC tap to clean any rusted threads and blow out any remaining fragments with compressed air. If there is a cutting torch on the jobsite then use the oxygen setting to blast the threads clean. Hold a rag over the tapped hole to prevent flying dirt from blasting into your eyes.
- 2.) Clean the machined bottom surface of the gearbox and prepare to mount the clamp. If the clamp bolts should ever break, check the machined surface with a straight edge to make sure it is true and flat.
- 3.) Clean the machined surface of clamp. Eye-ball the entire surface for damage. Make sure the surface is flat and void of all dirt.
- 4.) Start by getting the center bolt in first and work outwards. Do not tighten bolts until you have all of the bolts started.
- 5.) Tighten bolts using a six-foot cheater pipe. If you do not have a cheater pipe then use a sledge hammer.
- 6.) Go around all bolts at least three times making sure they are tight.
- 7.) After vibrating the first pile, check the bolts again.
- 8.) If one bolt breaks, replace them all since they may be weak or cracked.
- 9.) Never operate the vibro with missing clamp bolts.

WARNING: Do not use grade five bolts. All bolts should be allen head cap screw bolts. If one bolt breaks then the others are damaged and must be replaced. Never drive piles if one bolt is broken. Bolts break only because they were not tight and the crew neglected to check them. A good operator insists that every bolt is checked twice daily.



OPERATION / MAINTENANCE MANUAL

MODEL 400 VIBRATORY DRIVER WITH MODEL 1200 POWER UNIT

7032 SOUTH 196th - KENT, WA. 98032 - (253) 872-0141 / FAX (253) 872-8710

IV. PREPARATION AND OPERATION

IV-3. Plumbing the Vibro Hoses to the Power Unit

There are five hoses leading from the vibro that must be connected to the power unit to begin operation (Please see section II-5, "Hose Identification, page 2-5.) The hoses attach to the power unit by screwing the quick dis-connect couplers onto the proper couplers of the power unit. The couplers on the power unit are mated with the couplers on the vibro so there is no chance of putting them on backwards. Please take the following steps when installing the couplers:

WARNING: TURN THE POWER UNIT OFF BEFORE INSTALLING COUPLERS

- 1.) Turn the power unit OFF.
- 2.) Clean all couplers with a can of ether if available. A clean dry cloth will also work but will require extreme care. Fittings must be spotless clean.
- 3.) Install couplers by screwing them onto their respective counterparts. Try to avoid cross-threading and maintain a straight line. Jerk the hose back and forth while turning coupler to aid installation effort. Push hard to get the big coupler threads started.
- 4.) Make sure fittings are tight. If they are properly cleaned they should run up tight with just a firm hand grip. However, they should be double checked with a chain wrench.
- 5.) Avoid over-tightening.
- 6.) If near salt water, spray with a light oil to prevent oxidation.
- 7.) Position the Power Unit so that vibrator has enough hose to reach the work. Avoid pulling too hard on hoses. Most hose failures are caused by pulling hoses off couplers.

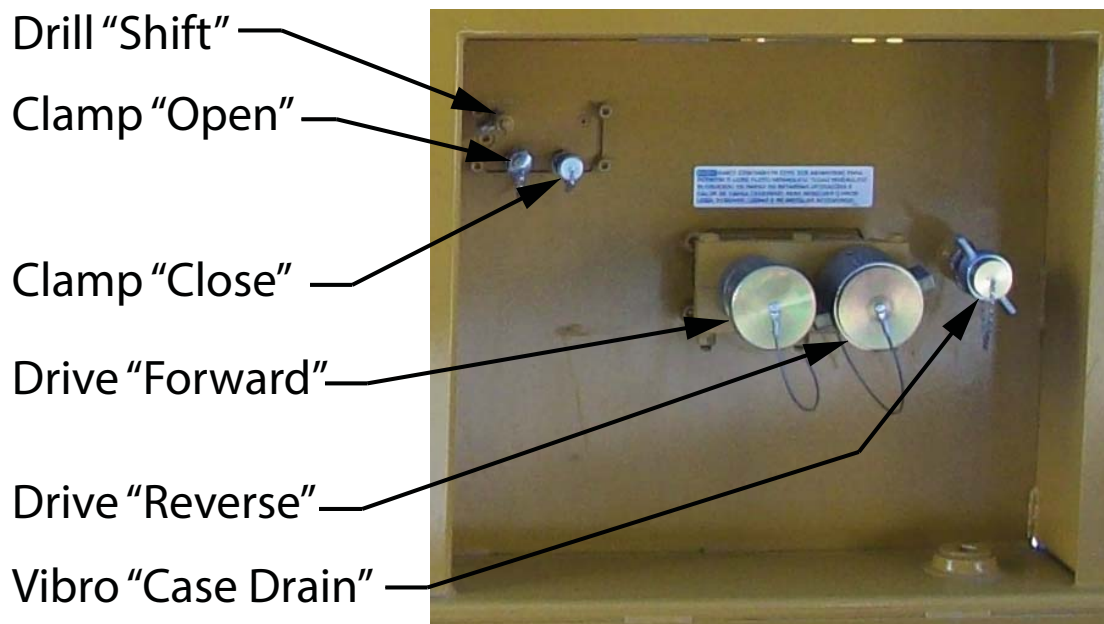

Figure 4-A. Power Unit Hose Plumbing

IV. PREPARATION AND OPERATION

IV-4. Filling Vibrator Pressure Hoses

The vibrator is shipped with the hoses filled with oil. However, if the unit has been sitting for a long period of time or if a damaged hose has been replaced with a new one, then the hoses must be filled. Hook up all the hoses to the power unit (see page 4-2). Start the power unit and let it run for ten minutes before running the vibro. The hoses will fill up by themselves in ten minutes even if the vibro is not in the vibrate mode.

IV-5. Bleeding the Clamp Attachment Hydraulic Hoses

If the opening and closing of the jaws seems spongy or slow, it may be a result of air in the clamp hoses. Normally there is no need to worry about bleeding the clamp lines because the unit is shipped fully tested. However, should the vibro sit for a long period of time, if a new attachment is being installed or if a damaged clamp hose has been replaced, then the system may require bleeding to remove unwanted air in the system. To bleed the clamp system, follow the following steps:

- 1.) Shut Power Unit OFF.
- 2.) Make sure the clamp line quick dis-connects are coupled to the power unit.
- 3.) Start the power unit engine and run at 1500 rpm. Give the engine time to warm up.
- 4.) Remove the clamp hoses at the hydraulic cylinder fittings and place ends into a bucket.
- 5.) Turn the clamp switch on the power unit control pendant to "CLOSE" and wait for oil to flow from the hose. **WATCH FOR AIR BUBBLES.** When air bubbles have stopped allow oil to run for a few seconds more. Turn clamp switch to off and replace hose to the cylinder fitting.
- 6.) Repeat the same procedure for "OPEN" side.
- 7.) Operate the jaws. If they are still a bit spongy then repeat bleeding steps once more.

WARNING: DO NOT BLEED SYSTEM AT FULL ENGINE THROTTLE BECAUSE TOO MUCH OIL WILL FLOW FROM THE HOSES AND COULD CAUSE INJURY.

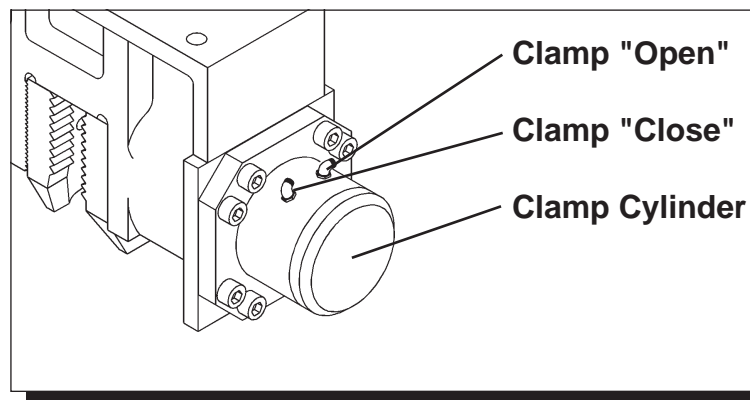

Figure 4-B. Bleeding Clamp Attachment



OPERATION / MAINTENANCE MANUAL

MODEL 400 VIBRATORY DRIVER WITH MODEL 1200 POWER UNIT

7032 SOUTH 196th - KENT, WA. 98032 - (253) 872-0141 / FAX (253) 872-8710

IV. PREPARATION AND OPERATION

IV-6. Precautions and Rules for Operation.

The following is a list of precautions, suggestions and rules that are intended to help promote the safe and productive use of the APE Model 400 Vibratory Driver.

- 1.) Follow the Daily Maintenance Required Prior to Operation, [Section V-1].
- 2.) Read and follow the Safety Precautions, [page iii].
- 3.) Follow the start-up procedures listed in the manual for the power unit being used.
- 4.) Start with piles in good condition.
- 5.) Put all teeth in pile.
- 6.) Drive in steps eight feet (2.5M) or less.
- 7.) Keep sheets plumb.
- 8.) Come up to speed before doing work.
- 9.) No dancing. Avoid densifying the soil.
- 10.) Drive past obstacles and then go back.
- 11.) Backhoe on site to remove obstacles.
- 12.) Lead with the ball.
- 13.) Probe the pile if it appears stuck.
- 14.) Keep piles plumb or down the road you go.
- 15.) Never rush the sheet pile foreman.
- 16.) Slow and plumb and the job will get done.
- 17.) Melted inner locks - piles out of plumb.
- 18.) Never stand under pile drivers.
- 19.) Low clamp pressure means jaw failures.
- 20.) Wait for vibro to get to full speed then pull.
- 21.) Don't over excavate - lower the ring.
- 22.) Look at the jaws during driving.
- 23.) Beware of cracked or broken sheets.
- 24.) In sandy soils drive faster. Vibration can cause settlement in loose, granular soils.
- 25.) In clay amplitude is everything.
- 26.) Low drive pressure means easy work.
- 27.) High pressure means friction on piles.
- 28.) Over 5000 psi means get a bigger vibro.
- 29.) No amplitude means get a bigger vibro.
- 30.) Caissons need heavy wall to avoid flex.
- 31.) Check clamp bolts each morning.
- 32.) Read the manual - know your machine.
- 33.) Attach whip line to pile when pulling.
- 34.) Know your line pull.
- 35.) Extract straight - look at boom and cable.
- 36.) Give boom stops some room.
- 37.) Stalled engine means dirty fuel filters.

IV. PREPARATION AND OPERATION

IV-7. Relief Valve Settings Prior to Operation

The Relief Valve and Pressure Switches are set by the factory. They will need to be re-set if the pressure switch is replaced.

- 1.) Do not hook up quick disconnects. Start and warm engine . Bring to full rpm.
- 2.) Check Clamp relief valve setting. On the Control Panel, turn the clamp switch to "OPEN" and hold it there while you read the CLAMP OPEN GAUGE on the panel. It should read 4800 PSI. If it is not coming up to pressure, then set the relief valve (FACTORY AUTHORIZED PERSONNEL ONLY), by loosening the lock nut and turning the knob in slowly until the proper pressure is reached. Turn in (CW) to increase pressure, and out (CCW) to decrease pressure. Tighten the locknut and recheck the pressure to make sure that the setting did not move during tightening the lock nut. When the clamp switch is turned to "OPEN" and held, a small light on the solenoid is illuminated, showing that there is power to the solenoid. Otherwise, the light on the solenoid should be off.

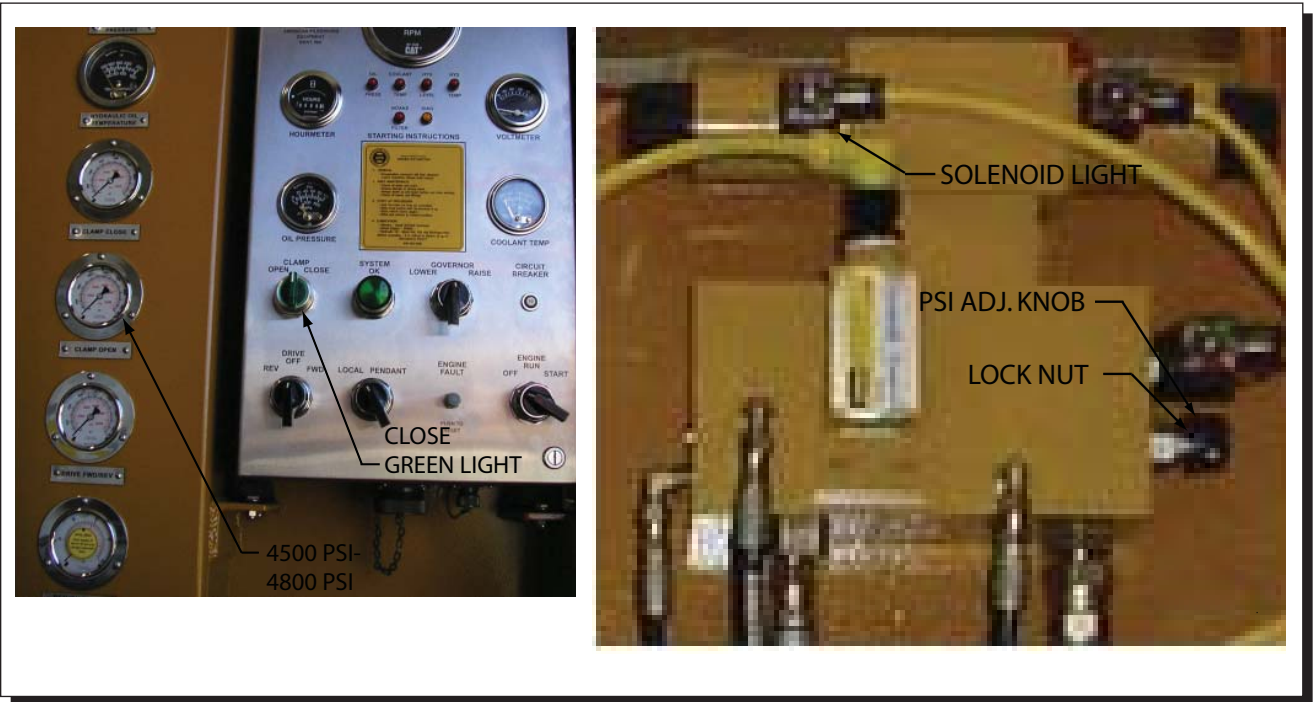

Figure 4-C. Setting Relief Valve

IV. PREPARATION AND OPERATION

IV-7. Relief Valve Settings Prior to Operation (Continued...)

- 3.) Check the clamp pressure switch setting. Turn the clamp to "CLOSE". If there is proper clamp pressure the CLAMP CLOSE GAUGE should read 4500 PSI to 4800 PSI, and the GREEN LIGHT comes on (see figure 4-D.)



Figure 4-D. Checking Clamp Pressure Switch Setting

- 4.) Adjust the clamp pressure switch setting. (If necessary). To set the pressure switch, turn the adjustment screw out using a screwdriver. (Turn it out a few turns counter-clockwise.) Turn clamp switch to "OPEN" for a second. Make sure the CLAMP OPEN GAUGE reads 4800 PSI. If it does not, then go back to the Step 2 and set the clamp relief valve first.

With clamp relief set at 4800 PSI, turn the clamp switch to "CLOSE". Green light should be on and clamp pressure should be very low or not reading at all.

Turn Adjustment Screw in (CW) until the green light goes off. Then, turn adjustment screw out (CCW) until green light comes on. (About 1/4 to 1/2 turn.) The CLAMP CLOSE GAUGE should read 4000 to 4800 PSI.

To check, turn clamp switch to "OPEN". The green light should be on.

Repeat procedure if necessary.



OPERATION / MAINTENANCE MANUAL

MODEL 400 VIBRATORY DRIVER WITH MODEL 1200 POWER UNIT

7032 SOUTH 196th - KENT, WA. 98032 - (253) 872-0141 / FAX (253) 872-8710

IV. PREPARATION AND OPERATION

IV-8. Shut-down Procedures

The following procedures explain what to do with the power unit to correctly shut down the APE Model 400 Vibratory Driver.

- 1.) Stop the vibrator. (Refer to the power unit operating manual .)
- 2.) Allow the diesel engine to run for five minutes at 1000 engine rpm.
- 3.) Reduce engine speed to low idle for about 60 seconds.
- 4.) Shut engine off by turning off the main power switch.

WARNING: Do not shut the power unit engine down while the vibrator is clamped onto a pile. The clamp check valve will slowly bleed off if there is any leakage in the hose lines or worn clamp seals in the cylinder that moves the jaw open or closed.

IV-9. Suppressor Housing - Gearbox Mating.

If the Suppressor Housing and Gearbox must be shipped separately, the following will assist in re-assembling these components. Normally, the Gearbox assembly is shipped with the Top Plate attached by several bolts at either end.

Place gearbox on flat, sturdy, surface.

Clean the upper surface of the Top Plate, and the bottom surface of the Inner Suppressor. These surfaces must be clean of all dirt, rust, paint or protective coverings.

Place Suppressor Housing on top of the Gearbox assembly (with Top Plate).

Lubricate and insert the 1.0-8UNC X 8.00 Lg. socket head bolts with Hi Collar Lock Washers to get the two large assemblies aligned. Start threading bolts by hand to ensure thread engagement. When all bolts are started, proceed with preliminary tightening (approx. 50 Ft-lbs [6.9 Kg-M]). Continue tightening, with a torque wrench, in stages, with a "center out" sequence, applying about 100-200 Ft-Lbs (13.8-27.6 Kg-M) per stage. The final pass at full torque should be 1010 Ft-Lbs (139.4 Kg-M).

The drive, case drain, and clamp hoses need to be connected to the Top Plate. These hoses are to be aligned on the Top Plate as they come from the manifold and hose clamp. (See assembly drawing on page 2-2).

The drive and return hoses are to be connected using the double split flange. Make sure there is an o-ring in the end of the hose, and all area surfaces are clean. Some o-ring lube should be used. The 0.75-10UNC X 2.50Lg socket head bolts with Hi Collar Lock Washers for the double split flange are to be lubricated, inserted and tightened evenly until the torque of 240 Ft-lbs (33.2 Kg-M).

The case drain and clamp lines are connected to JIC type fittings. Make sure the tapered connecting surfaces are clean to ensure a good, steel to steel, seal. Tighten these fittings so that they do not leak or vibrate loose.



OPERATION / MAINTENANCE MANUAL

MODEL 400 VIBRATORY DRIVER WITH MODEL 1200 POWER UNIT

7032 SOUTH 196th - KENT, WA. 98032 - (253) 872-0141 / FAX (253) 872-8710

IV. PREPARATION AND OPERATION

IV-10. Operation of the Control Pendant

- 1.) All functions of the vibro can be controlled by the control pendant. It is the choice of the crew as to where best to locate the control pendant. Some prefer that the crane operator control all functions. Others prefer to give it to one of the ground crew so it can be positioned close to the work at hand. A 50 foot (15.2 M) cord is provided as standard equipment. If this is not long enough, additional 50 foot (15.2 M) sections can be added. Should the control pendant become damaged, all functions can be manually operated. See page 7-16 in this manual for more details on operation. See page 7-21 of this manual for wiring diagram and control pendant components.

IV-11. Normal steps to operate vibrator:

(Note: In order to operate power unit, Drive must be "OFF").

1. Position vibro on pile.
2. Set power unit speed to full throttle (factory set 1950 RPM).
3. Turn Clamp to "CLOSE" the switch will stay in the "CLOSE" position and wait for light to come on.
4. Turn Drive to "FWD" to direct hydraulic oil to Vibro.
5. To drive piles, lower crane line as vibro vibrates pile.
6. To extract, pull up on vibro while vibrating.
7. See "Precautions and Rules for Operation" in this manual for more detailed operations on driving and extracting piles.
8. To stop the vibro turn Drive to "OFF".
10. To release clamp, turn clamp switch to "OPEN" clamp light will turn off. Once the jaws are open release the switch.

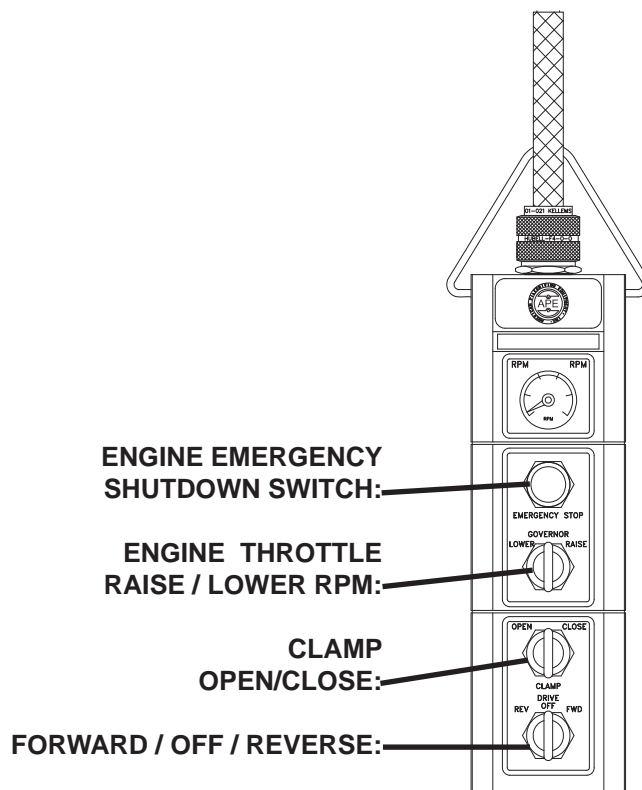

Figure 4-E. Control Pendant

V. MAINTENANCE

V-1. Daily Maintenance Required Prior to Operation

- 1.) Visually inspect the entire vibro for loose nuts or bolts. Put a wrench on the clamp bolts and check them for tightness.
- 2.) Grease the Jaw Plunger on the clamp housing.
- 3.) Check the oil level in the vibrator. Hang vibro from crane and look at sight gauge. Make sure the oil is half way up gauge. If you cannot read it then you can't run the vibro. Remove the gauge and clean it by spraying a shot of starting fluid at it. **YOU MUST KNOW THE LEVEL!**

IF THE OIL LOOKS MILKY OR CONTAMINATED THEN DRAIN THE GEARCASE AND ADD NEW OIL.

If you cannot read it then do not assume the level is ok.

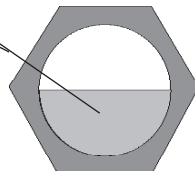

Sight Gauge

**Oil Level
Schaeffer 268
or equivalent.
(do not use veg. oil)**

- 4.) If the oil is milky or contaminated then change it. **Change the oil every 75 hours.**
- 5.) Check the fluid level in the power unit hydraulic tank.
- 6.) Look at all the hoses. Check for cuts or other damage that might cause an oil leak.
- 7.) Check the Elastomers (rubbers) in the suppressor housing. Look for cracks.
- 8.) **Check the following items:**

Check water level in radiator	Check engine oil
Check battery level	Check hydraulic return filter indicator
Check fuel level	Check fan belts on engine
Check oil level in pump drive	Check entire unit for hydraulic leaks
Check hydraulic oil level	Check condition of jaws before operating

V-2. Checklist After Power Unit Engine Has Started

- 1.) Check all hydraulic hoses for leaks. Make sure they hang free with no kinks.
- 2.) Check inside the Power Unit. Look at all hoses and valves, check for leaks.
- 3.) Check return filter gage at control panel with engine running at full rpm and hydraulic oil temperature above 80 degrees F. Replace filter when pressure is above 50 psi.
- 4.) Check wire rope sling and make sure it is in excellent condition.
- 5.) Check jaws for wear. Replace if necessary.
- 6.) Close jaws, make sure clamp light comes on.



OPERATION / MAINTENANCE MANUAL

MODEL 400 VIBRATORY DRIVER WITH MODEL 1200 POWER UNIT

7032 SOUTH 196th - KENT, WA. 98032 - (253) 872-0141 / FAX (253) 872-8710

V. MAINTENANCE

V-3. Maintenance and Adjustments (75 Hours)

Change the oil in vibrator gearbox. Remove the drain plug from bottom of gearbox and drain the oil into a bucket. Check oil for any metal shavings. Replace oil in gearbox by adding 20.6 gallons of standard weight oil. Schaeffer 268.

Clean the gearbox breathers each time the oil is changed. Replace the breathers if necessary.

V-4. Maintenance and Adjustments (Eccentric Bearings)

- 1.) **Model 400** - The Eccentric Bearings should be checked and/or replaced after every 2500 hours of operation.

V-5. Maintenance and Adjustments in Severe Conditions

When average temperature is above (80 deg. F) or below (-1 deg. F) reduce servicing intervals to one half of those specified above.

When operating in the presence of dust or sand, reduce servicing intervals to one-third of those specified.

During stand-by or inactive periods, the servicing intervals may be reduced to one-half. The unit should be run every 30 days or less to keep internal parts lubricated.

V-6A. Lubrication - Vibratory Gearbox

The Gearbox oil should be changed when black or milky. Schaeffer 268 or equal is the preferred oil. The gearbox requires 20.6 gallons of oil.

V-6B. Lubrication - Clamp Attachment

The Clamp Attachment hydraulic oil must be checked and changed on a regular basis. The Clamp Cylinder Plunger should be checked for rust and debris. Lubricate the plunger on a regular basis using the grease zert on the side of the clamp housing.



OPERATION / MAINTENANCE MANUAL

MODEL 400 VIBRATORY DRIVER WITH MODEL 1200 POWER UNIT

7032 SOUTH 196th - KENT, WA. 98032 - (253) 872-0141 / FAX (253) 872-8710

V. MAINTENANCE

V-7A. Power Unit - Filters, Fluid Types and Capacities

FILTERS

<u>LOCATION</u>	<u>QTY</u>	<u>ENGINE</u>	<u>FILTER TYPE</u>	<u>APE P/N</u>
Engine Oil:	2	Caterpillar C-32	Caterpillar #1R-1808	521033
Engine Fuel:	1	Caterpillar C-32	Caterpillar #1R-0755	555139
Eng. Fuel Water Sep:	1	Caterpillar C-32	Caterpillar #326-1641	
Air Filter Outer	2	Caterpillar C-32	Caterpillar #6I-2509	521025B
Air Filter Inner	2	Caterpillar C-32	Caterpillar #6I-2510	521025A
Hyd. Oil Filter:	4		Zinga #ZLE-10	555009
Hand Pump Filter:	1		Zinga #AE-25	533011

Table 5-A. Power Unit Filters

ENGINE OIL TYPES AND CAPACITIES

<u>LOCATION</u>	<u>ENGINE</u>	<u>OIL TYPE</u>	<u>CAPACITY</u>
Hydraulic Oil-Main:	-----	Terresolve Enviologic 146	475 gallons
Hyd Oil-Reserve:	-----	Terresolve Enviologic 146	90 gallons
Engine Oil:	Caterpillar C-32	SAE 15W40 CH-4	72 quarts
Engine Water:		See note below	35 gallons
Fan Drive:	-----	Multi-Purpose Grease	
Pump Drive:	-----	Schaeffer 268	2 gallons
Fuel Tank :	-----	Diesel	180 gallons

Table 5-B. Power Unit Oil Types and Capacities

Caterpillar Extended Life Anti-freeze p/n 119-5150 mix with water 50/50.
 Caterpillar Extended Life Anti-freeze p/n 101-2844 premixed.
 See page 5-7 for details on lubrication of the pump drive.



OPERATION / MAINTENANCE MANUAL

MODEL 400 VIBRATORY DRIVER WITH MODEL 1200 POWER UNIT

7032 SOUTH 196th - KENT, WA. 98032 - (253) 872-0141 / FAX (253) 872-8710

V. MAINTENANCE

V7-B. Power Unit - Hydraulic Fluid

When adding or changing hydraulic fluid APE uses only Terresolve Invirological 146 Hydraulic fluid which is non-toxic and will not harm soil or water and is biodegradable. Consult your local oil supplier for recommendations on mixing hydraulic oils. Change hydraulic oil if it looks milky. This includes all hydraulic lines leading to and from the vibro. Milky oil indicates that water is in the oil.

V7-C. Power Unit - Two Part Hydraulic Fluid Tank

The Hydraulic Tank is a two part tank. The main tank which the pumps feed from, cooled and filtered oil returns. The upper tank is an auxiliary tank to store extra or surplus hydraulic oil. Hydraulic oil may be transferred from the auxiliary tank to the main tank.

There is a valve on the bottom of the main hydraulic tank that should be opened into a bucket periodically before the engine is started. Water that may get into the system will settle to the bottom of the hydraulic tank, opening this valve will allow that water to be removed from the system.

V7-D. Power Unit - Draining and Filling Hydraulic Fluid Tank

- 1.) Shut down power unit by turning off the diesel engine.
- 2.) Place warning tag on control panel so that no one mistakenly starts the unit while tank is not operational.
- 3.) Remove cap and open drain valve located on bottom of main hydraulic tank. When tank is empty we recommend opening side cover(s) to confirm the tank is clean inside.
- 4.) Replace covers, close drain valve and replace cap.
- 5.) Refill using hand pump and filter.
- 6.) Prime both the clamp and the main pump before restarting.
- 7.) Take extreme caution that no dirt or other unwanted particles enters the system.



OPERATION / MAINTENANCE MANUAL

MODEL 400 VIBRATORY DRIVER WITH MODEL 1200 POWER UNIT

7032 SOUTH 196th - KENT, WA. 98032 - (253) 872-0141 / FAX (253) 872-8710

V. MAINTENANCE

V-7E. Power Unit - Changing Hydraulic Return Filter Element

The hydraulic return filters are mounted to dual head adapters on the hydraulic tank inside the power unit. They are mounted high on the tank so that when the filter elements are removed the oil will not drain from the hydraulic tank. The filter adapter has a gage at the control panel to tell you when it is dirty. When the hydraulic oil is above 80 degrees F and the return filter gauge reads 50 PSI it is time to change the filters.

V-7F. Power Unit - Steps to Remove the Hydraulic Filter Elements

- 1.) Shut down power unit by turning off the diesel engine.
- 2.) Place warning tag on control panel so that no one mistakenly starts the unit while filters are being changed.
- 3.) Clean area around filters so that when they are removed there is no chance of introducing dirt into the hydraulic system.
- 4.) Using a filter wrench, turn the filter counter clockwise and spin the filter off of the filter housing.
- 5.) Install new clean filter making sure the o-ring is in place.
- 6.) Always change all four filters at the same time.



OPERATION / MAINTENANCE MANUAL

MODEL 400 VIBRATORY DRIVER WITH MODEL 1200 POWER UNIT

7032 SOUTH 196th - KENT, WA. 98032 - (253) 872-0141 / FAX (253) 872-8710

V. MAINTENANCE

V-8. Bolt Torque Information

Torque, in foot-pounds, is determined by the length of the wrench handle (in feet) multiplied by the weight (or force in pounds) applied at the end of the handle. For example, if the wrench is one foot long and five pounds of force is applied at the end of the handle, the total torque applied would be five foot pounds. A six inch wrench would require ten pounds of force to obtain five foot pounds of torque.

The only way to actually tighten high strength bolts is with proper lubrication and a torque wrench. Proper use of the torque wrench is important. To obtain the listed torques, a steady pull should be exerted to the handle until the desired torque is reached.

The following torque specifications apply to the bolts from the vibrator assemblies listed. Whenever any of these bolts, are installed or replaced, the given torque specifications should be adhered to.

<u>Vibro Final Assembly Identification</u>		<u>Page 2-2</u>
Item 12	3/4"-10	233 Ft-Lbs (32.3 Kg-M)
Item 7, 8	1"-8	1,009 Ft-Lbs (139.4 Kg-M)
<u>Suppressor Identification</u>		<u>Page 2-4</u>
Item 22	5/8"-11	233 Ft-Lbs (32.3 Kg-M)
Item 9, 10, 11, 16, 18	3/4"-10	417 Ft-Lbs (57.6 Kg-M)
Item 14	1"-8	1009 Ft-Lbs (139.4 Kg-M)
<u>Gearbox Identification</u>		<u>Page 2-6 & 2-7</u>
Item 21, 30	1/2"-13	119 Ft-Lbs (16.4 Kg-M)
Item 27	5/8"-11	233 Ft-Lbs (32.3 Kg-M)
Item 29, 35	3/4"-10	417 Ft-Lbs (57.6 Kg-M)
Item 41	1"-8	1009 Ft-Lbs (139.4 Kg-M)
<u>CLAMP BODY</u>		<u>Page 2-12 & 2-14</u>
Item 4	5/8"-11	233 Ft-Lbs (32.3 Kg-M)
Item 15, 19, 29	1"-8	1009 Ft-Lbs (139.4 Kg-M)
Item 26	1 -1/2"-6	2800 Ft-Lbs (387 Kg-M)
<u>Caisson Clamp Body</u>		<u>Page 2-20</u>
Item 15	5/8"-11	233 Ft-Lbs (32.3 Kg-M)
Item 11	1 -1/4"-12	1800 Ft-Lbs (248.8 Kg-M)
<u>Caisson Clamp Cylinder</u>		<u>Page 2-20</u>
Item 11	5/8"-18	267 Ft-Lbs (36.9 Kg-M)

V. MAINTENANCE

V-9. Power Unit - Pump Drive

PUMP DRIVE LUBRICATION for APE Model 1200 Power Unit

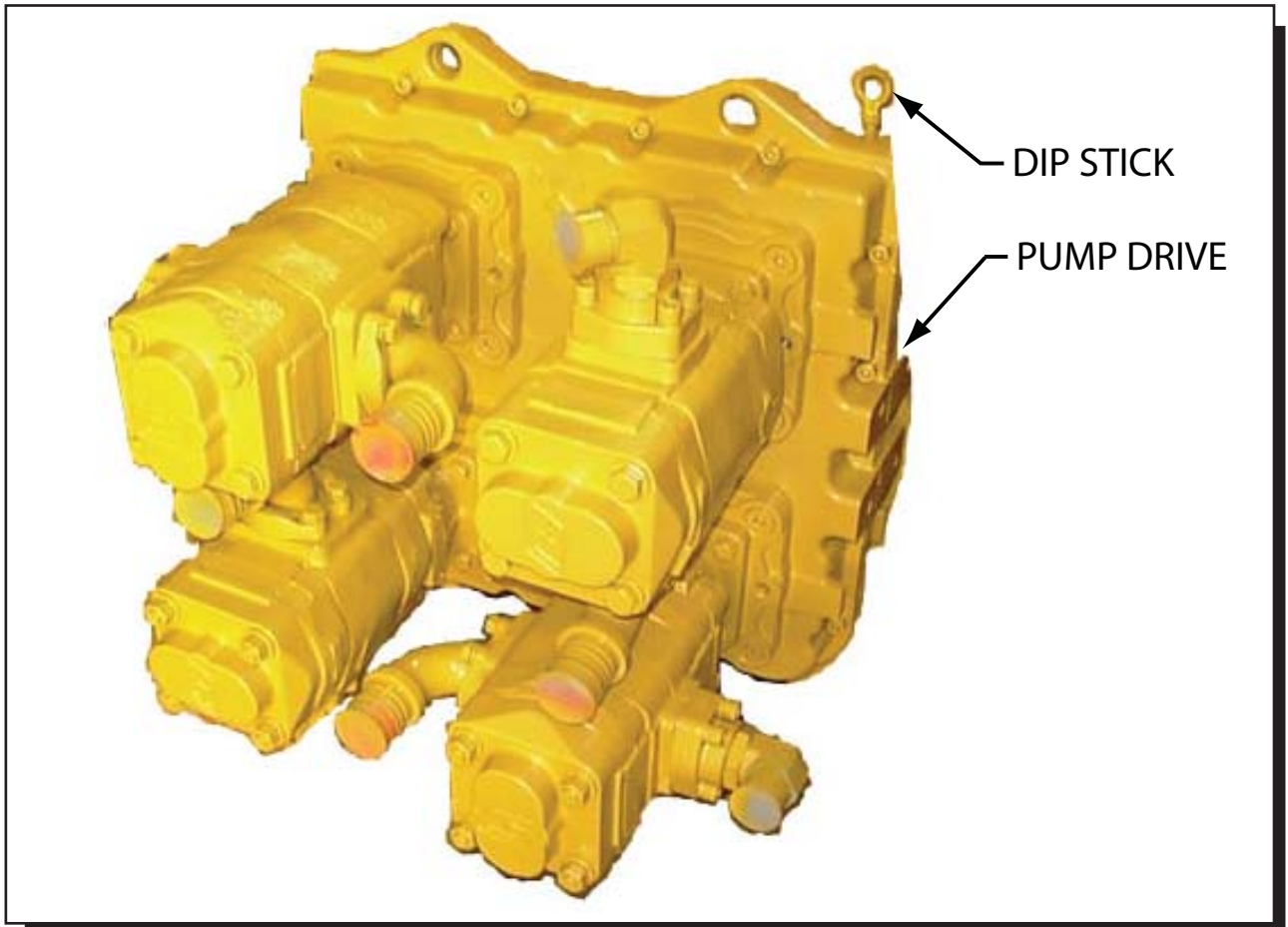

Figure 5-A. Pump Drive - Durst D12547

The pump drive used on the APE 1200 power unit is a gear box that requires lubrication. The main gearbox takes about 2 gallons of oil. Check the level using the dip stick.

Oil changes are suggested every six months or 2,000 hours, which ever occurs first.

Fill with Schaeffer 268. Before operating the unit, check the oil level dip stick.



OPERATION / MAINTENANCE MANUAL

MODEL 400 VIBRATORY DRIVER WITH MODEL 1200 POWER UNIT

7032 SOUTH 196th - KENT, WA. 98032 - (253) 872-0141 / FAX (253) 872-8710



OPERATION / MAINTENANCE MANUAL

MODEL 400 VIBRATORY DRIVER WITH MODEL 1200 POWER UNIT

7032 SOUTH 196th - KENT, WA. 98032 - (253) 872-0141 / FAX (253) 872-8710

VI. VIBRO TROUBLE-SHOOTING

The following table lists some possible problems, causes and solutions. If a serious problem should occur, contact the factory for additional service information.

<u>ITEM</u>	<u>PROBLEM</u>	<u>ITEM</u>	<u>PROBLEM</u>
1.	Oil Blowing Out Between Gear box and Hydraulic Motor.	6.	Vibrator Won't Start When Forward Switch is Engaged.
2.	Vibro Gearbox is Too Hot.	7.	Clamp Won't Open When Clamp Open Switch is Engaged.
3.	Excess Oil in the Gearbox.	8.	Vibro Won't Come Up to Normal Operating Speed.
4.	Oil Blowing Out From Pop-Off Valve.	9.	Vibro Won't Stop When Stop Button is Engaged.
5.	Opening and Closing Clamp Jaws Seems Spongy or Slow.		

Table 6-A. Vibro Trouble-Shooting Index

Possible Cause

Remedy

1. Oil Blowing Out Between Gearbox and Hydraulic Motor.

The breather may be plugged or damaged.

Remove the breather and clean it. If the breather is damaged replace it.

O-rings may not be sealing properly

Check the o-rings between the gearbox top plate and the motor. Clean the seal areas and replace the o-rings if needed.

2. Vibro Gearbox is Too Hot.

Oil level may be too high.

Make sure the gearbox is level. Remove the oil over fill plug (located on the gearbox next to the sight gage). If oil flows out, the oil level is too high and must be lowered.

Oil may be too dirty.

Look at oil in the sight gage. If the oil is milky or contaminated it must be replaced. If you are still not sure, remove the gear box drain plug and check the oil.

3. Excess Oil in the Gearbox.

The seal between the gearbox and the hydraulic motor may be bad and is allowing hydraulic oil to flow directly into the gearbox.

Remove the motor from the face of the gearbox. Check and clean the seal area, replace the seal if it looks bad.

4. Oil Blowing out Pop-Off Valve.

Blocked flow in case drain line.

Check case drain line to see if it is pinched.

Valve may be bad.

Check case drain line for proper connection tightness.

One or both motors may be damaged.

Remove and check the valve. Replace the valve if needed.

Remove the motors and have them checked for damage. Replace if needed.



OPERATION / MAINTENANCE MANUAL

MODEL 400 VIBRATORY DRIVER WITH MODEL 1200 POWER UNIT

7032 SOUTH 196th - KENT, WA. 98032 - (253) 872-0141 / FAX (253) 872-8710

VI. VIBRO TROUBLE-SHOOTING

Possible Cause

Remedy

5. Opening and Closing Clamp Jaws Seems Spongy or Slow.

The plunger shaft may not be properly lubricated or may need cleaning.

Remove the movable jaw from the clamp. Inspect the plunger shaft and check for lubrication or debris build up. Clean the shaft if needed and then lubricate using the grease zert on the clamp body.

The clamp hoses may have air in them and may need bleeding.

Follow the procedures listed in this manual (page 4-3) for bleeding the clamp attachment hydraulic hoses.

6. Vibrator Won't Start When Start Switch is Engaged.

Hoses may be connected improperly.

Check hoses and make connection corrections if required.

One or both hydraulic motors may not be operating properly.

Remove the case drain hose from a motor and plug the port connecting it to the other motor. Hold the case drain hose so that the oil will flow into a bucket. Run the Vibrator, if a large amount of oil flows from the case drain hose the motor needs to be replaced or rebuilt. Do the same procedure to the other motor.

Vibrator gearbox may be frozen up.

If motors are working fine and the drive pressure appears normal, then the vibro gearbox may be frozen and in need of repair.

Drive pressure is too low.

Manually close start valve at the drive manifold. If vibro will not start, replace the start valve. If vibro will not start, replace the drive pump.

7. Clamp Won't Open When Clamp Open Switch is Engaged.

Vibrator is running.

The clamp won't open while the vibro is in operation. To open the clamp, stop the vibro.

There may be an electrical failure.

Check for the following:

- Defective CLAMP switch in pendant, flip "LOCAL / PENDANT" switch to "LOCAL" and use CLAMP switch on main panel.
- Broken or loose wire in the pendant or pendant cable.
- Defective OPEN solenoid.
- Broken or loose wire between main power switch and START relay.
- Defective or sticking clamp timing delay relay.
- Broken or loose wire between main power switch and amphenol connector.

The clamp pump may be defective.

Replace clamp check valves. If clamp still wont open, replace the clamp pump.



OPERATION / MAINTENANCE MANUAL

MODEL 400 VIBRATORY DRIVER WITH MODEL 1200 POWER UNIT

7032 SOUTH 196th - KENT, WA. 98032 - (253) 872-0141 / FAX (253) 872-8710

VI. VIBRO TROUBLE-SHOOTING

Possible Cause

Remedy

8. Vibro Won't Come Up to Normal Operating Speed.

Defective hydraulic motor or drive pump. If vibration frequency has been verified lower than normal, Replace the hydraulic motors one at a time to see if performance improves. If vibro still operates below normal speed, replace drive pump.

9. Vibro Won't Stop When Stop Switch is Engaged.

There may be an electrical failure. Check for the following:

- Defective REVERSE / OFF / FORWARD switch in pendant, flip "LOCAL / PENDANT" switch to "LOCAL" and use REVERSE / OFF / FORWARD switch on main panel.
- Broken or loose wire in the pendant or pendant cable.
- Defective START valve.



OPERATION / MAINTENANCE MANUAL

MODEL 400 VIBRATORY DRIVER WITH MODEL 1200 POWER UNIT

7032 SOUTH 196th - KENT, WA. 98032 - (253) 872-0141 / FAX (253) 872-8710

VII. MODEL 1200 POWER UNIT

VII-1. Hydraulic Circuitry

VII-1A. Clamp Circuit (Used for extending and retracting jaw cylinder Item "F".)

Oil for the clamp circuit is provided by pump "D1". All oil to the inlet of this pump flows from the reservoir (Item "A") through a shut-off valve, which must be open at all times. Oil is then directed from the pump to the Clamp/Drill manifold "C" which contains the clamp control valve. When the clamp switch is in the neutral position, the oil flows through the clamp directional control valve and back to the oil tank. When clamp switch is moved to OPEN, solenoid "B" (on the clamp directional control valve) is energized the oil will flow out to the clamp cylinder and retract (open) the jaws. The clamp open pressure can be seen on the clamp pressure gage. When the clamp switch is moved to CLOSE, solenoid "A" (on the clamp directional control valve) will be energized and oil flow will be directed to the clamp cylinder. The clamp cylinder will then extend (close) the jaws. When clamp comes up to pressure 4800 psi, solenoid "A" will be de-energized, directing pump oil flow back to oil tank. Clamp pressure is maintained in clamp cylinder by a pilot operated check valve. At any time should the clamp pressure fall below 4500 psi. the clamp pressure switch will re-energize solenoid "A" and direct pump flow to the clamp cylinder. Maximum clamp pressure is limited by the clamp pressure relief valve set at 4800 psi. The quick disconnect couplers permit decoupling of clamp hoses.

VII-1B. Drive Circuit (Used for operating APE vibrator, APE drill or any other unit, Item "B".)

Oil for the drive circuit is provided by pumps "D2", "D3" and "D4". All oil to the inlets of these pumps flows from the reservoir (Item "A") through shut-off valves which must be open at all times. Oil is then directed from the pumps to the Drive manifold "B" which contains the drive control valve. When the drive switch is in the neutral position, the oil flows through the drive control valve and back to the oil tank. When the drive switch is moved to FORWARD, that direct oil to the drive circuit (Vibro Motors). The maximum drive pressure is controlled by the drive pressure relief valve, to 4500 psi max. When the drive switch is moved to the FWD position, solenoid "B" of the drive directional control valve is energized. Oil flow is directed to the vibro motors to rotate the eccentrics. When the drive switch is moved to the OFF position, oil flow is directed back to the tank through the drive directional control valve and solenoid "B" is de-energized.

The quick-disconnect couplings permit de-coupling of the drive and case drain hoses.

VII. MODEL 1200 POWER UNIT

VII-1C. Hydraulic Schematic.

- | | |
|---|----------------|
| A | RESERVOIR |
| B | DRIVE MANIFOLD |
| C | CLAMP MANIFOLD |
| D | PUMPS |
| E | VIBRO |
| F | CLAMP CYLINDER |

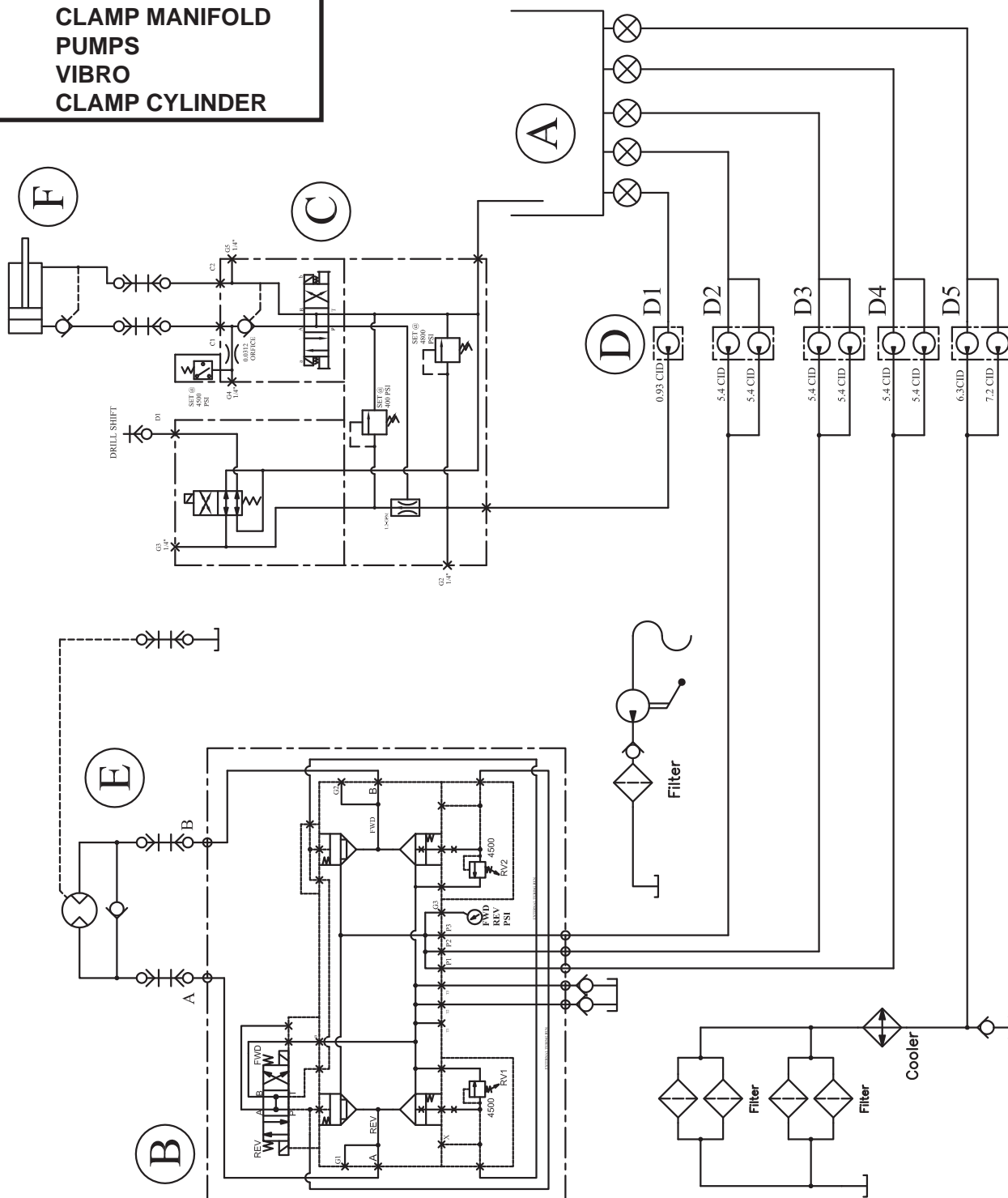

Figure 7-A. Hydraulic System Schematic

VII. MODEL 1200 POWER UNIT

VII-1D. Hydraulic Components - Clamp Drill Manifold Assembly

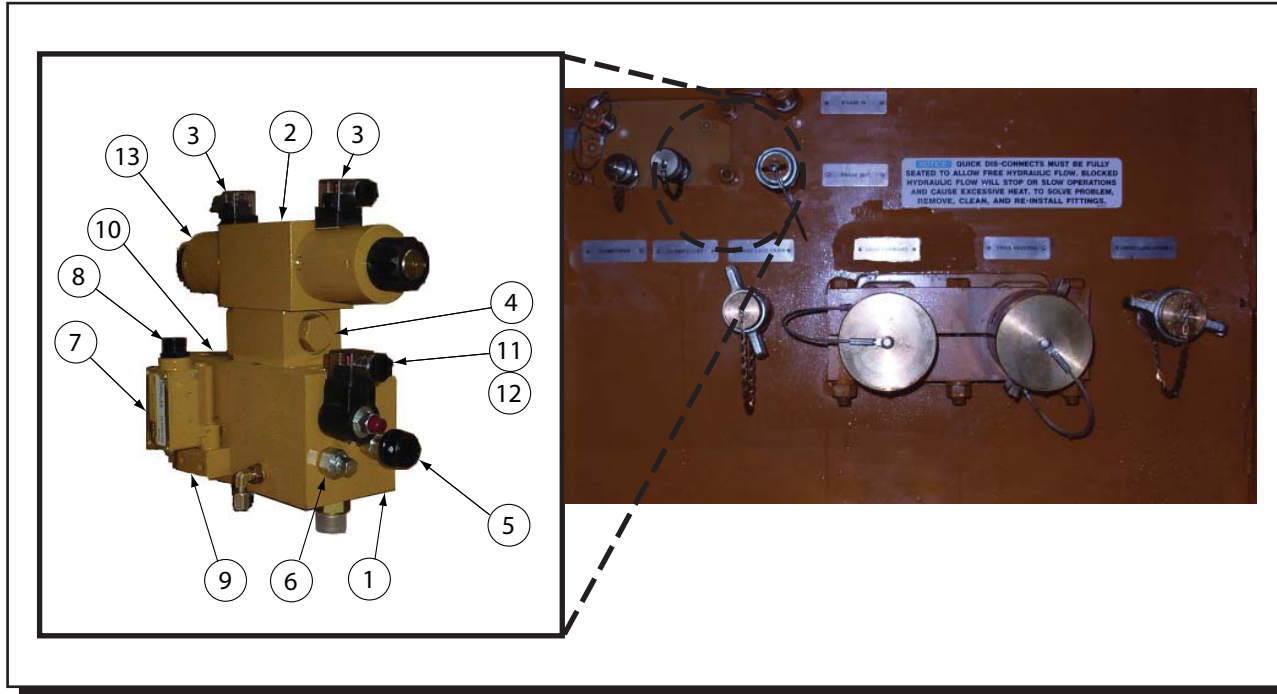

Figure 7-B. Clamp Drill Manifold Assembly 523003B

ITEM	APE PART NO.
1. MANIFOLD MACHINED	555073
2. CONTROL VALVE	555075
3. LIGHTED CONNECTOR	555077
4. PO CHECK VALVE	555079
5. CLAMP RELIEF VALVE	555081
6. DRILL RELIEF VALVE	555083
7. PRESSURE SWITCH	555085
8. STR SO COR CONNECTOR	555087
9. 90 DEG. TURN BLOCK	555089
10. PRIORITY FLOW CONTROL	555091
11. DRILL SOLENOID VALVE	555093
12. DRILL COIL	555095
13. CONTROL VALVE COIL	543049

Table 7-A. Clamp Drill Manifold Assembly 523003B

VII. MODEL 1200 POWER UNIT

VII-1D. Hydraulic Components - Clamp Drill Manifold 523003B

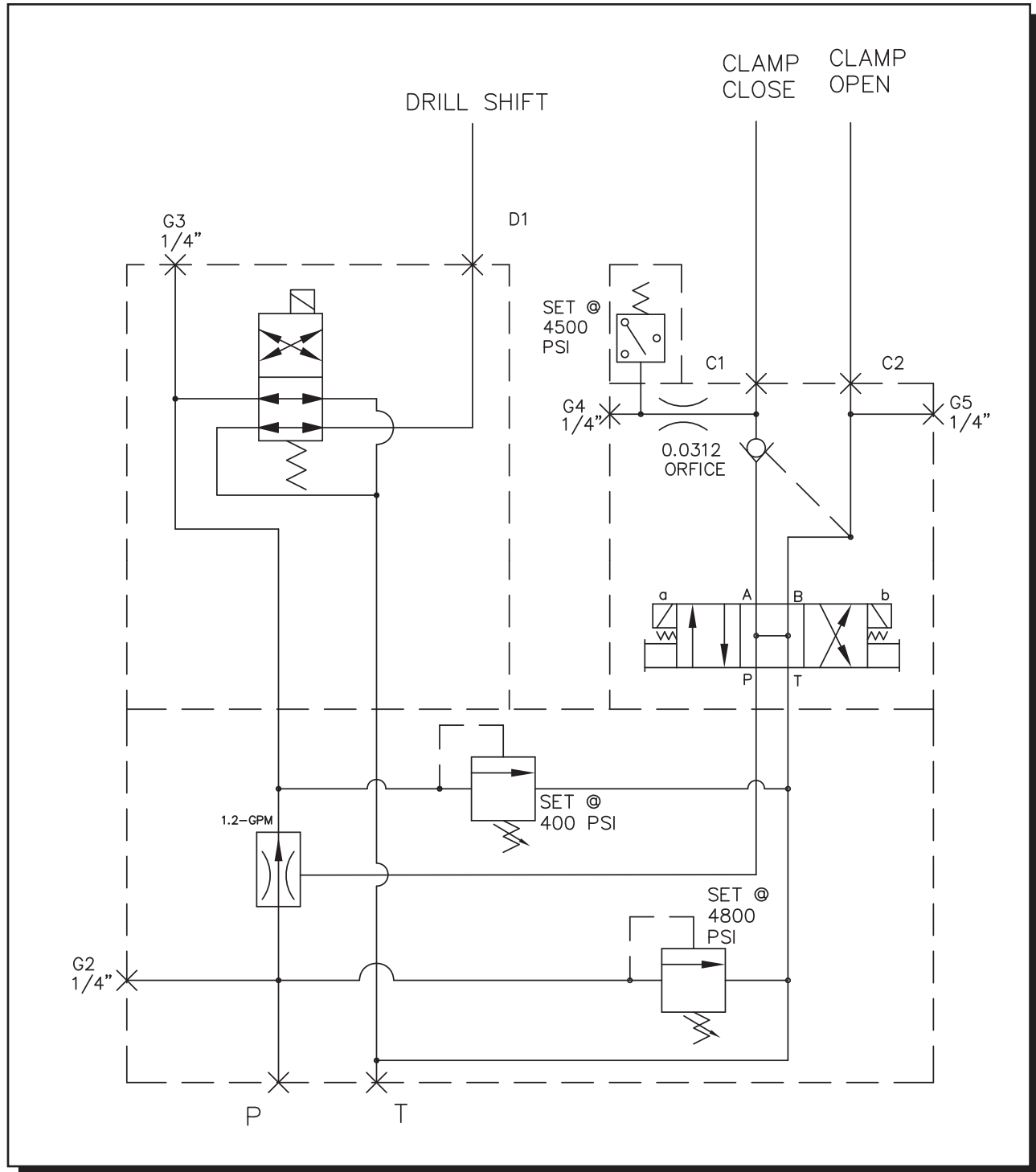

Figure 7-C. Hydraulic Schematic - Clamp Drill Manifold

VII. MODEL 1200 POWER UNIT

VII-1E. Hydraulic Components - Drive Manifold Assy. 555183

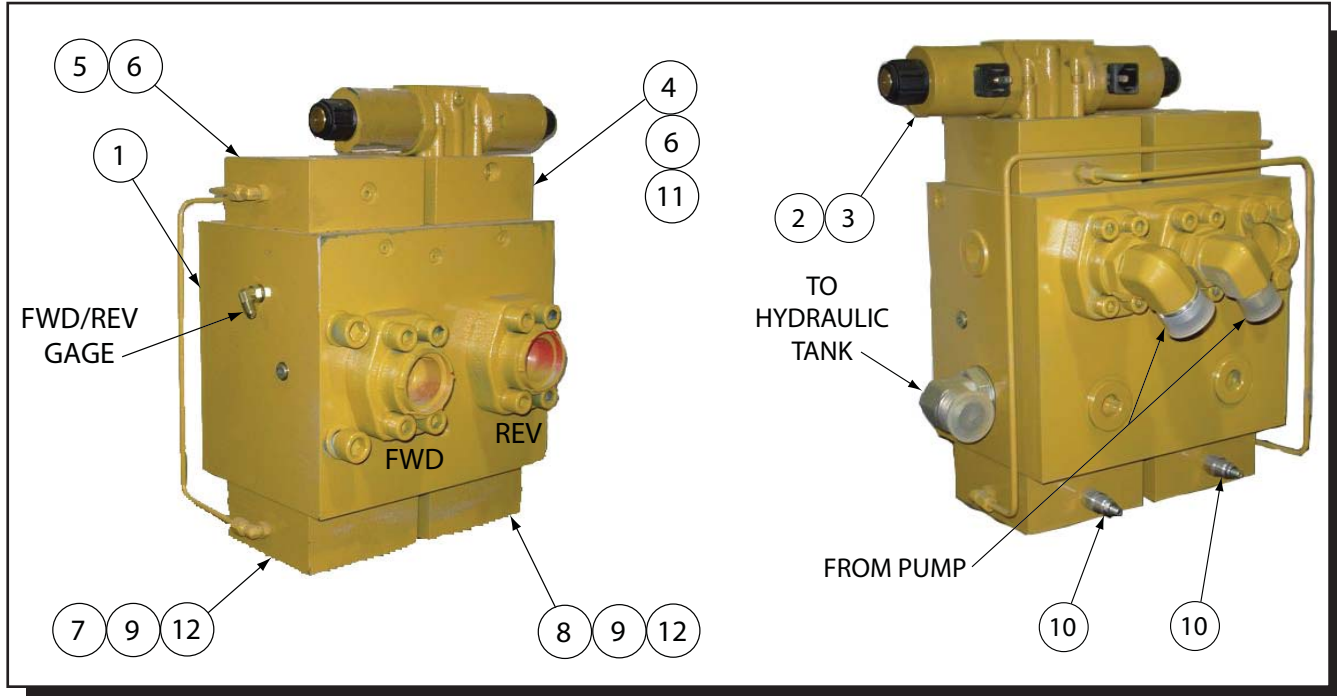

Figure 7-D. Drive Manifold Assembly 555183

<u>ITEM</u>	<u>APE PART NO.</u>
1. MANIFOLD MACHINED	555185
2. SOLENOID CONTROL VALVE	555075
3. SOLENOID COIL	543049
4. CA1 CART COVER	555187
5. CA2 CART COVER	555189
6. CARTRIDGE CA1 & CA2	555203
7. CB2 CART COVER	555193
8. CB1 CART COVER	555191
9. CARTRIDGE CB1 & CB2	555201
10. RELIEF VALVE	555195
11. ORIFICE	555197
12. ORIFICE	555199

Table 7-B. Drive Manifold Assembly 555183

VII. MODEL 1200 POWER UNIT

VII-1E. Hydraulic Components - Drive Manifold Assy. 555183

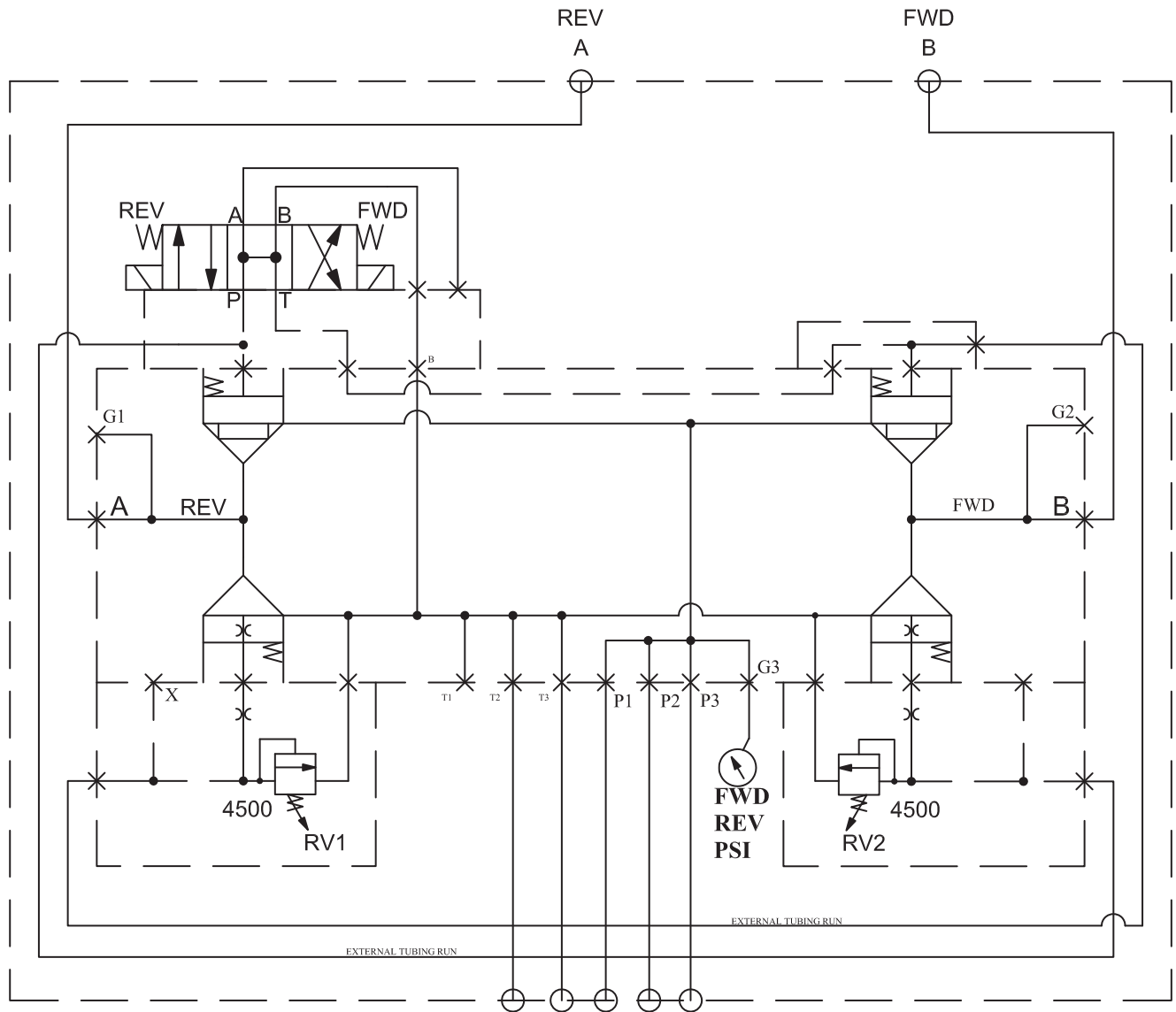

Figure 7-E. Hydraulic Schematic- Drive Manifold



OPERATION / MAINTENANCE MANUAL

MODEL 400 VIBRATORY DRIVER WITH MODEL 1200 POWER UNIT

7032 SOUTH 196th - KENT, WA. 98032 - (253) 872-0141 / FAX (253) 872-8710



OPERATION / MAINTENANCE MANUAL

MODEL 400 VIBRATORY DRIVER WITH MODEL 1200 POWER UNIT

7032 SOUTH 196th - KENT, WA. 98032 - (253) 872-0141 / FAX (253) 872-8710

VII. MODEL 1200 POWER UNIT

VII-1F. Hydraulic Components Hose Identification and Routing

QTY	DESCRIPTION	PARKER HOSE
1	Drive Forward & Reverse Gauge	F3010606-4-4-4-130"
1	Return Filter (Gauge)	F3010606-4-4-4-231"
1	Return Filter Jumper	F3010606-4-4-4-13 1/2"
1	Clamp Open Gauge	F3010606-4-4-4-118"
1	Clamp Close Gauge	F3010606-4-4-4-119 1/2"
1	Drill Shift	F3010606-4-4-4-115 1/2"
1	Engine Oil Pressure Gauge	9190606-4-4-4-96"
1	Hand Pump (Pressure)	F8110606-16-16-16-56 1/2"
1	Hand Pump (Suction)	F8110606-20-20-20-138 1/2"
1	Drive Pump Pressure	F78C0606-20-20-20-34 3/4"
1	Drive Pump Pressure	F78C0606-20-20-20-46 3/4"
1	Drive Pump Pressure	F78C0606-20-20-20-81"
1	Drive & Recirc Pumps Suction	811-32 141"
1	Recirculation Pump (Press. to Cooler)	F3010606-24-24-24-132 1/2"
1	Cooler to Filter	F3010606-24-24-24-219 1/2"
1	Hoop Hose	F8110606-24-24-24-41"
1	Recirculation Pump (Check. to Filter)	F3010606-24-24-24-44"
1	Hydraulic Tank transfer	F8110606-20-20-20-25 3/4"
1	Clamp Manifold Return	F451TC0606-12-12-12-64"
1	Fuel (Tank to Filter)	F451C0606-8-8-8-68"
1	Fuel (Return)	F451C0606-6-6-6-40"
1	Clamp Pump (Suction)	F8110606-16-16-16-60"
1	Clamp Pump (Press. to Clamp Manifold)	F471TC0606-8-8-8-32"
1	Vibro Case Drain	F471TC0606-16-16-16-50"
1	Drive Manifold (Return)	F3010606-24-24-24-26 1/4"
1	Drive Manifold (Return)	F3010606-24-24-24-28"
1	Radiator Shunt	801-16-41"

Table 7-C - Hose Identification and Routing

VII. MODEL 1200 POWER UNIT

VII-1G. Hydraulic Components - Hydraulic Tank Connections

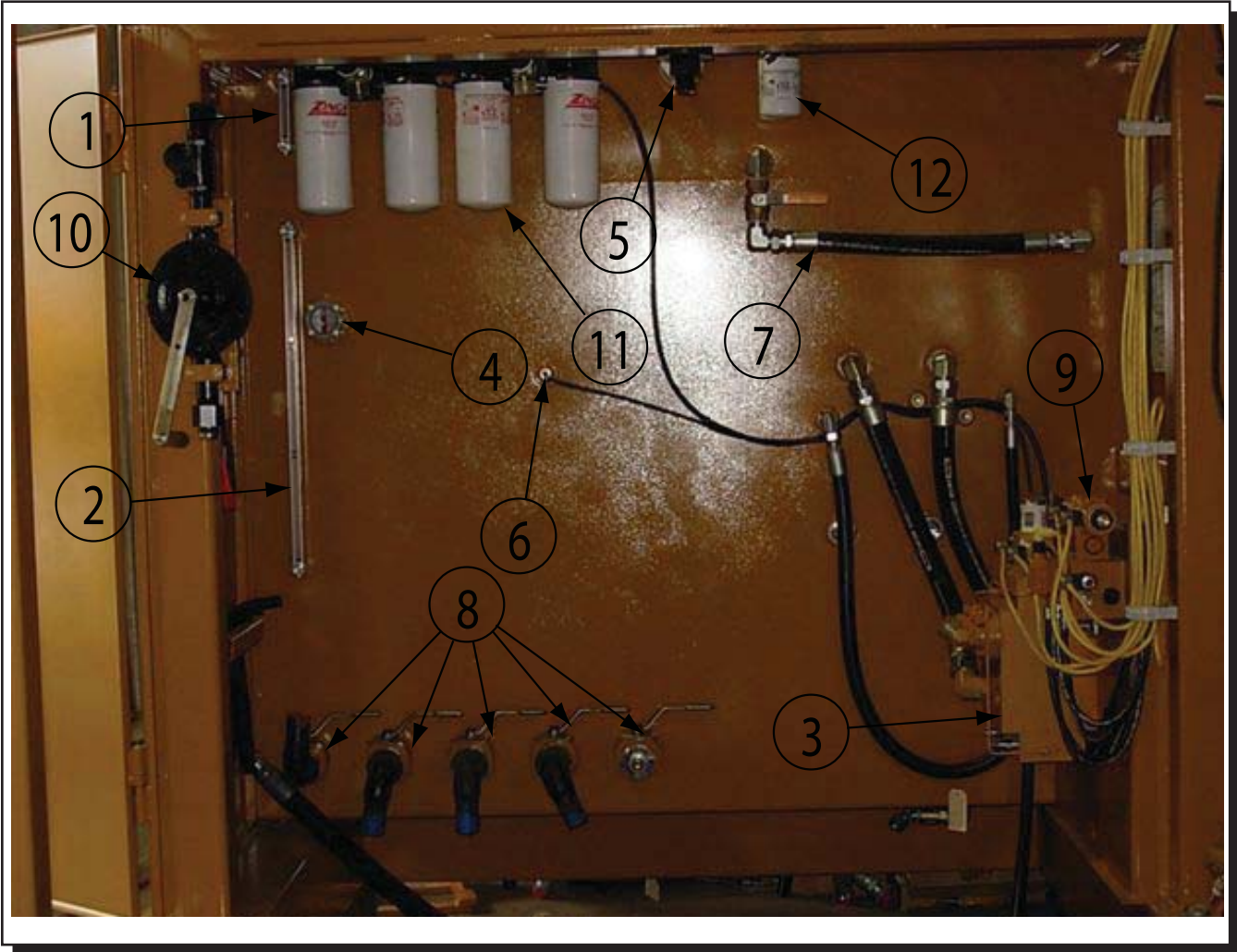

Figure 7-F. Hydraulic Component Identification - Tank Detail



OPERATION / MAINTENANCE MANUAL

MODEL 400 VIBRATORY DRIVER WITH MODEL 1200 POWER UNIT

7032 SOUTH 196th - KENT, WA. 98032 - (253) 872-0141 / FAX (253) 872-8710

VII. MODEL 1200 POWER UNIT

VII-1G. Hydraulic Components - Hydraulic Tank Connections (Continued...)

ITEM DESCRIPTION	APE PART NO.
1 6" SITE GAGE	513003
2 30" SITE GAGE	513005
3 DRIVE MANIFOLD ASSY.	555183
4 LEVEL SWITCH	513033
5 AIR BREATHER	555141
6 TEMP. SWITCH	523016
7 HYD. TANK TRANSFER ASSY.	
8 SUCTION VALVE (TO PUMPS)	555001
9 CLAMP/DRILL MANIFOLD	523003B
10 MANUAL PUMP	
11 RETURN FILTER	
12 MANUAL PUMP FILTER	

Table 7-D. Hydraulic Component Identification - Tank Detail



OPERATION / MAINTENANCE MANUAL

MODEL 400 VIBRATORY DRIVER WITH MODEL 1200 POWER UNIT

7032 SOUTH 196th - KENT, WA. 98032 - (253) 872-0141 / FAX (253) 872-8710

VII. MODEL 1200 POWER UNIT

VII-1H. Return Filter.

Returning fluid is filtered by the return filter.

VII-1I. Oil Cooler.

The oil cooler cools the hydraulic fluid is continuously pumped thru cooler while the engine is running. This cooler is protected by a check valve that will bypass oil back to hydraulic tank.

VII-1J. Manual Pump.

A manual pump is provided to fill the hydraulic reservoir a filter in place to see only clean oil enters the reservoir. A check valve prevents loss of fluid from the reservoir back through the manual pump.

VII-1K. Hydraulic Oil Temperature.

A temperature gauge indicates hydraulic oil temperature. The sending unit is mounted on the main tank.

VII. MODEL 1200 POWER UNIT

VII-1L. Hydraulic Components - Hydraulic Pumps

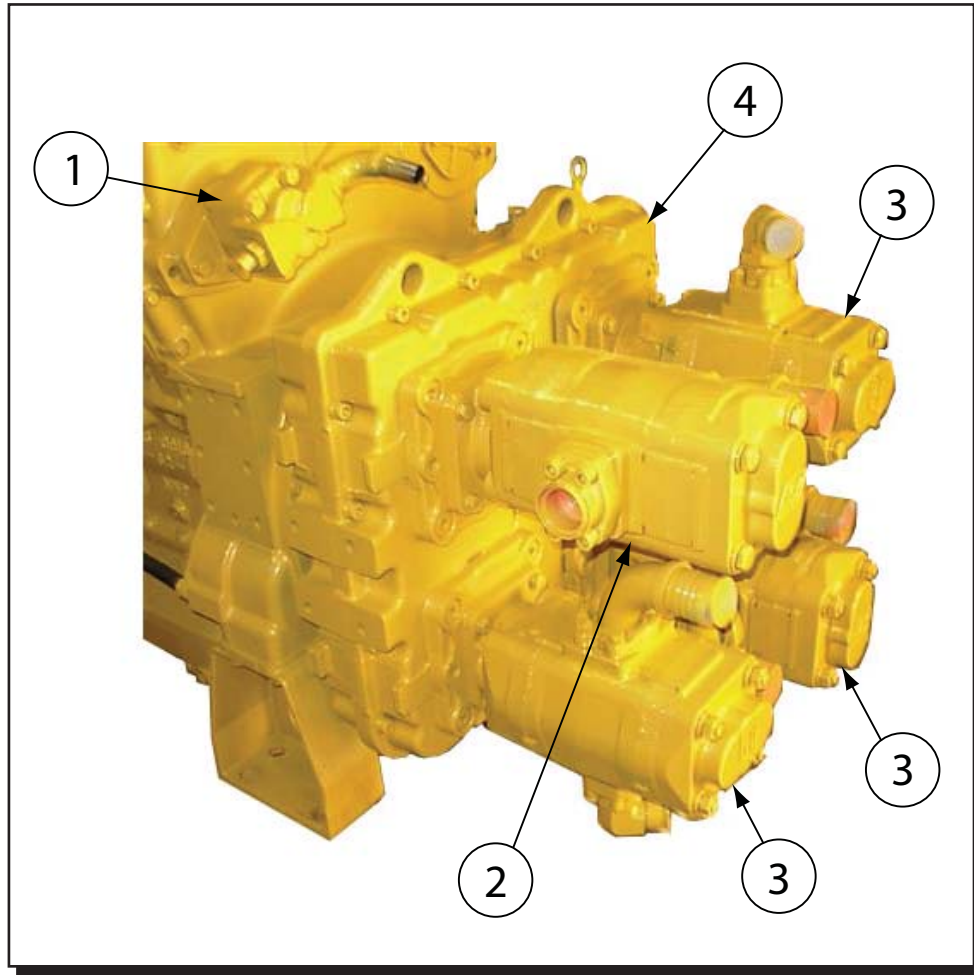

Figure 7-G. Hydraulic Pumps

ITEM	DESCRIPTION	QTY	PART NUMBER	FUNCTION
1	Clamp Pump RH (on engine)	1	543099	Clamp and Drill Shift
2	Recirc Pump	1	543097	Cooler / Filter
3	Vibro Drive Pump	3	543085	Vibro
4	Pump Drive	1	555275	Connect Engine to Pumps

Table 7-E. Hydraulic Pumps



OPERATION / MAINTENANCE MANUAL

MODEL 400 VIBRATORY DRIVER WITH MODEL 1200 POWER UNIT

7032 SOUTH 196th - KENT, WA. 98032 - (253) 872-0141 / FAX (253) 872-8710

VII. MODEL 1200 POWER UNIT

VII-2. Electrical Controls: (Understanding How They Work)

The Main Control Panel (located behind one of the doors on the left side of the Power Unit) contains all of the equipment necessary to Start, Control, and Monitor the Engine, as well as control the Vibro functions. Remote control of the Vibro functions can be achieved by plugging either a Remote Pendant Switch, or a Radio Receiver into the 12 pin receptacle, located on the bottom of the panel. The Pendant Switch will allow the operator to move about in approx. a 50 ft radius of the Power Unit. The Radio will allow the operator to move about in approx. a 400 ft radius of the Power Unit.

VII-2A. Main Circuit Breaker

A circuit breaker is provided to protect the control wiring in the event of an electrical overload or a shorted circuit. If the circuit breaker should trip, find and repair the fault, then reset the breaker by pressing the circuit breaker reset button on the face of the Control Panel.

VII-2B. Tachometer

A digital tachometer, located on the front of the control panel, is provided to monitor the engine RPM. A magnetic sensor picks up a signal from the flywheel, and sends it to the tachometer. If there is reason to doubt the accuracy of the tachometer, check the engine RPM with a phototach, then calibrate the tachometer gage. The factory should be consulted for proper setting of the tach switches.

VII-2C. Hourmeters

Two hourmeters are on the Control Panel, one on the face of the panel, and one inside the panel. The hourmeter on the face of the panel monitors the time that the engine is running. The hourmeter inside the panel monitors the time that the "Forward Drive" is operating.

VII-2D. Engine Safety Shutdown Switch (Murphy Magnetic Switch)

Mounted to the back side of the Control Panel Door, is a Murphy Magnetic switch with a manual reset button protruding through the front of the Panel Door. When the contact on the switch is closed, power is supplied to the fuel valve solenoid, the hourmeter, and the "System OK" light. When the contact is open, the above items will be de-energized, and the engine will not run. The contact can be manually closed by pressing the "Reset" button on the face of the control panel. The contact will remain latched closed, unless the coil on the switch is energized. Each time the coil is energized, the contact will be unlatched, and the contact will open, to stop the engine. There are five switches that can energize the coil on the Murphy magnetic Switch, to stop the engine, (Engine Oil Pressure Gage, Engine Coolant Temperature Gage, Hydraulic Oil Temperature Gage, Hydraulic Oil Level Switch, and Emergency Stop Button on either the Pendant Switch, or the Radio).



OPERATION / MAINTENANCE MANUAL

MODEL 400 VIBRATORY DRIVER WITH MODEL 1200 POWER UNIT

7032 SOUTH 196th - KENT, WA. 98032 - (253) 872-0141 / FAX (253) 872-8710

VII. MODEL 1200 POWER UNIT

VII-2E. Murphy “Engine Oil Press” gage

The Engine Oil Pressure Gage is located on the door of the Main Control Panel. A low cutoff switch is located inside the Murphy “Engine Oil Press” gage. When the engine oil pressure is too low, the switch will close to energize the coil in the Murphy Mag Switch. The cutoff pressure has been set at the factory. If the setting should need to be changed, use the adjustment screw provided in the front of the gage. A 1/16” allen wrench is required. Each time the engine is to be started, the Murphy Mag Switch coil will be energized by the switch in this gage. To start the engine, one must press and hold the manual reset button on the Murphy Mag Switch until sufficient engine oil pressure is achieved. Sufficient oil pressure has been achieved when the “Oil Press” light on the face of the Control Panel goes out.)

VII-2F. Murphy “Engine Coolant Temp” gage

The Engine Coolant Temperature Gage is located on the door of the Main Control Panel. A high cutoff switch is located in the Murphy “Engine Coolant Temp” gage. When the engine temperature is too high, the switch will close to energize the coil in the Murphy Mag Switch. The cutoff temperature has been set at the factory. If the setting should need to be changed, use the adjustment screw provided in the front of the gage. A 1/16” allen wrench is required. (Do not set the cutoff temperature above 220 deg F. without factory permission)

VII-2G. Murphy “Hyd Oil Temp” gage

The Hydraulic Oil Temperature Gage is located in the Gage Assembly on the left of the Control Panel. A high cutoff switch is located in the Murphy “Hyd Oil Temp” gage. When the hydraulic oil temperature is too high, the switch will close to energize the coil in the Murphy Mag Switch. The cutoff temperature has been set at the factory. If the setting should need to be changed, use the adjustment screw provided in the front of the gage. A 1/16” allen wrench is required.

VII-2H. Hydraulic Oil Level Float Switch

The “Hyd Oil Level” float switch is located in the hydraulic oil reservoir, next to the sight gage. A glass window is provided in the switch so that the float and oil level can be observed. If the oil level gets too low, the switch will close to energize the coil in the Murphy Mag Switch.

VII-2I. “Emergency Stop” button

To stop the engine in an emergency, press the “Emergency Stop” button on the Remote Pendant Switch. This “Emergency Stop” switch will work, regardless of the position of the “Local-Pendant” selector Switch. There are two “Emergency Stop” switches on the power unit shell to also stop the engine in an emergency.



OPERATION / MAINTENANCE MANUAL

MODEL 400 VIBRATORY DRIVER WITH MODEL 1200 POWER UNIT

7032 SOUTH 196th - KENT, WA. 98032 - (253) 872-0141 / FAX (253) 872-8710

VII. MODEL 1200 POWER UNIT

VII-2J. Pilot lights

There are five pilot lights on the face of the control panel that are associated with the Safety Shutdown Switch discussed above.

1. "System OK" light. A lit "System OK" light is an indication that the Engine Oil Pressure, Engine Coolant Temperature, Hydraulic Oil Temperature, and the Hydraulic Oil Level are all okay. When the "System OK" light is not lit, the engine will have been automatically stopped. The problem can be detected by observing the following lights.
2. "Engine Oil Press" light. Any time the engine oil pressure is too low, this light will be on, (with the following exception). If the "Engine Coolant Temperature Gage", the Hydraulic Oil Temperature Gage, or the Hydraulic Oil Level Switch has stopped the engine, the "Engine Oil Press" light will not be on; but, one of the following lights will be on.
3. "Engine Coolant Temp" light. If the Engine Coolant Temp is too high, this light will be on.
4. "Hydraulic Oil Temp" light. If the Hydraulic Oil Temperature is too high, this light will be on.
5. "Hydraulic Oil Level" light. Any time the Hydraulic Oil Level is too low, this light will be on.

In addition to the above, there is a pilot light in each of the terminal connectors on the solenoid valves. By observing these lights, one can tell which solenoids are energized.

VII-2K. Engine Control Switch "OFF-ON-START"

The Engine Control Switch is located on the front of the control panel, and is used to start and stop the diesel engine, as well as control power to all other electrical equipment on the power unit. This switch must be in the "on" position before the engine or any of the other electrical components will operate. The "off" and "on" positions are detented, but the "start" position is spring loaded to the "on" position. Turning the switch to the "start" position will energize the starter motor on the engine. The Local Remote switch must be in the local position for the engine control switch to be energized.

VII-2L. "LOCAL—PENDANT" Switch

This switch is also located on the main control panel, and determines the location from which the vibro can be operated. The vibro can not be operated from more than one location at a time. When this switch is turned to the "local" position, the vibro can be operated only by the switches on the power unit control panel. In the "pendant" position, operation of the vibro is controlled by either the Hand Held Pendant Switch, or the Radio (depending on which one is plugged into the bottom of the Control Panel).

CAUTION should be used when changing the position of this switch. Check to make sure that all of the Drive "Forward/Reverse" switches, and "Clamp" switches (including the Radio) are turned "off" before turning this switch. If any one of the above switches are "on", the vibro eccentrics or clamp could be accidentally activated, causing mechanical damage or personal injury.



OPERATION / MAINTENANCE MANUAL

MODEL 400 VIBRATORY DRIVER WITH MODEL 1200 POWER UNIT

7032 SOUTH 196th - KENT, WA. 98032 - (253) 872-0141 / FAX (253) 872-8710

VII. MODEL 1200 POWER UNIT

VII-2M. Governor Control Switches “RAISE-off-LOWER”

Governor Control switches can be found on the Main Control Panel, and the Held Pendant. The “Local-Pendant” switch determines which one is operable. To increase the engine rpm, turn the appropriate governor control switch to the “Raise” position. To decrease the engine rpm, turn the switch to the “Lower” position. On power units equipped with Caterpillar engines, the switches are connected directly to the engine governor. On power units equipped with Cummins engines, the switches control a Murphy Actuator, which in turn, operates a control arm on the engine governor. On both the Caterpillar and Cummins models, there is a manual throttle control, which can override the electric control. The electric control cannot lower the engine rpm below that set by the manual throttle control.

VII-2N. Clamp Control Switches (“OPEN-off-CLOSE”)

A Clamp Control Switch can be found on the Main Control Panel, the Hand Held Pendant, and/or the Radio Transmitter. The “Local-Pendant” switch determines which one is operable.

The Clamp Control Switches on the Control Panel and the Hand Held Pendant are detented in the “off” and “close” positions. The “open” position is spring loaded back to the “off” position.

When the ‘active’ Clamp Control Switch is in the “off” position, oil from the Clamp Pump is routed through the Clamp Solenoid Valve back to tank.

When the ‘active’ Clamp Control Switch is turned to the “open” position, The “open” solenoid on the Clamp Valve is energized, causing oil to be directed to the rod end of the Clamp Cylinder, provided the drive “Forward/Reverse” Switch is in the “off” position. (The clamp “open” solenoid cannot be energized when the “Drive Forward” switch is activated.) If the Clamp Control Switch is held in the “open” position after the clamp is fully open, oil pressure will build in the system until oil is flowing over a pressure relief valve, creating heat.

When the ‘active’ Clamp Control Switch is turned to the detented “Close” position, the “close” solenoid on the Clamp valve is energized, causing oil to be directed to the blind end of the Clamp Cylinder. Once the Clamp is closed, and sufficient oil pressure (4800psi) has built in the system, a pressure switch will open the circuit to the solenoid valve, and energize a pilot light located in the Clamp Control Switch Operator. A lit pilot light in the Clamp Control Switch Operator is an indication that there is enough oil pressure in the clamp circuit to safely run the vibro eccentrics.

If oil pressure in the Clamp circuit should bleed off to a predetermined level(4500psi), the pressure switch will de-energize the pilot light, and re-energize the “close” solenoid on the Clamp valve until pressure in the clamp circuit reaches 4800 psi again. This cycle will continue until the Clamp switch is turned to the “off “ position.



OPERATION / MAINTENANCE MANUAL

MODEL 400 VIBRATORY DRIVER WITH MODEL 1200 POWER UNIT

7032 SOUTH 196th - KENT, WA. 98032 - (253) 872-0141 / FAX (253) 872-8710



OPERATION / MAINTENANCE MANUAL

MODEL 400 VIBRATORY DRIVER WITH MODEL 1200 POWER UNIT

7032 SOUTH 196th - KENT, WA. 98032 - (253) 872-0141 / FAX (253) 872-8710

VII. MODEL 1200 POWER UNIT

VII-20. Drive Control Switches (“FORWARD/off/REVERSE”)

Drive Control Switches can be found on the Main Control Panel and the Hand Held Pendant. The “Local-Pendant” Selector Switch determines which one is operable. The Drive Control Switches on the Control Panel and the Hand Held Pendant are detented in all three positions. They must be in the “off” position before the engine can be started.

Turning the switch to FORWARD will start the vibro eccentrics spinning. To stop vibro turn the switch to off. When operating the eccentrics on a vibro, only the “Forward” drive should be used. If the “Reverse” drive is used, the majority of the oil will pass through the anti-cavitation valves located in the vibro suppresser housing, and the vibro eccentrics will not run properly.

NEVER SWITCH FROM "FORWARD" TO "REVERSE" WHILE VIBRO IS OPERATING.

VII-2P. Preparing the Electrical System for Engine Startup.

The following procedure should be followed at Engine Startup:

1. The Circuit Breaker must be closed (Pushed in and locked).
2. Turn the Clamp Switches on both the Control Panel and the Pendant to the ‘Off’ position.
3. Turn the Drive Switch on both the control panel and the Pendant to the ‘Off’ position.
4. Turn the Engine Control Switch to the ‘On’ position.
5. Check the Pilot Lights on the face of the Control Panel. If any of the lights, other than the “Engine Oil Pressure’ light is on, correct the problem before proceeding. If the ‘Engine Oil Pressure’ light is on, proceed to step #8.
6. Depress and hold the button on the Engine Safety Shutdown Switch (Murphy Switch). This button must be depressed until Engine Oil Pressure is present.
7. Turn the Engine Control Switch to the ‘Start’ Position to engage the Starter Motor. Once the engine is running release the Engine Control switch. It will return to the RUN position.
8. Once Engine Oil Pressure is present, release the Engine Safety Shutdown Switch.

VII. MODEL 1200 POWER UNIT

VII-2Q. Electrical Schematic

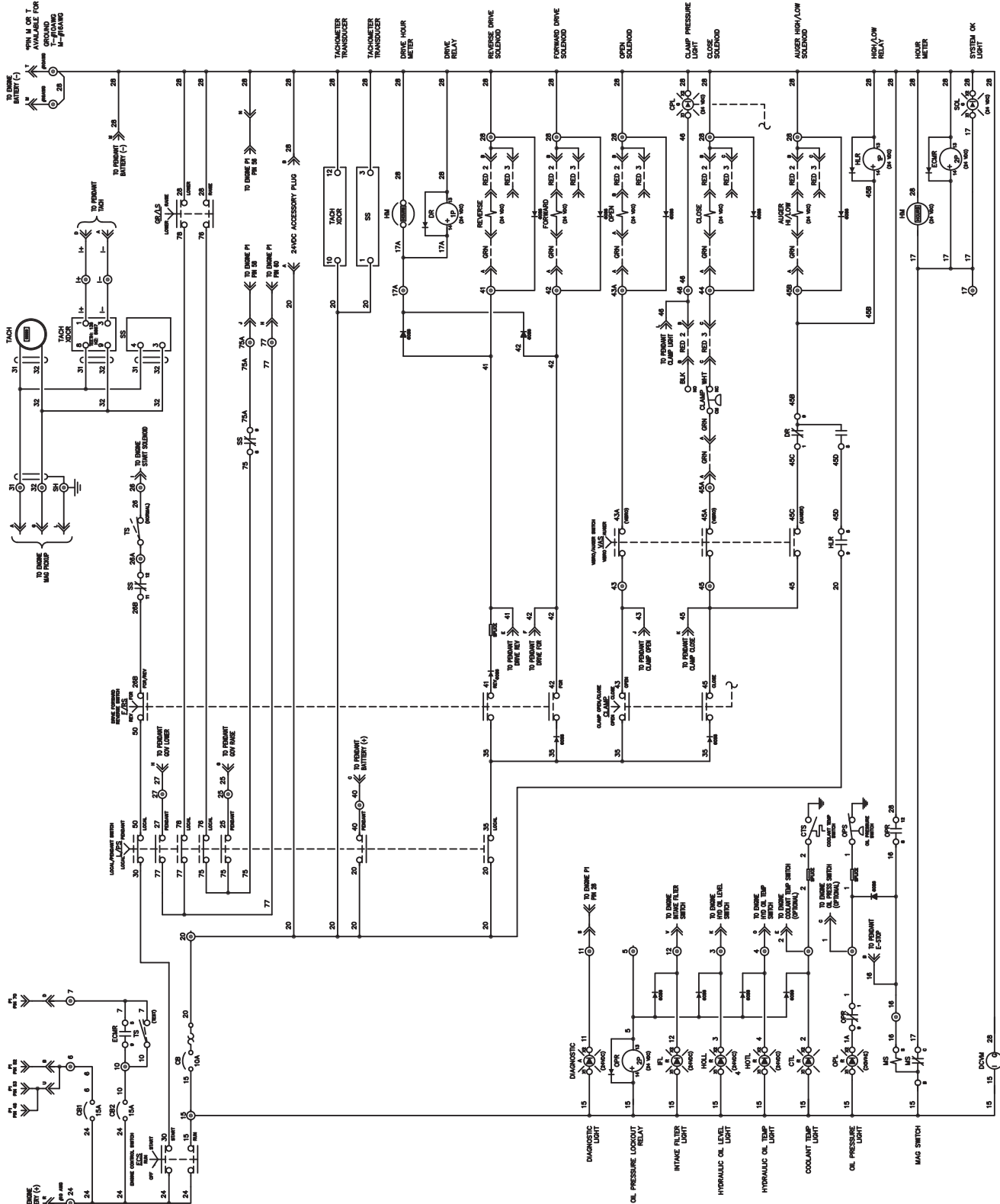



OPERATION / MAINTENANCE MANUAL

MODEL 400 VIBRATORY DRIVER WITH MODEL 1200 POWER UNIT

7032 SOUTH 196th - KENT, WA. 98032 - (253) 872-0141 / FAX (253) 872-8710

VII. MODEL 1200 POWER UNIT

VII-2R. Electrical Symbol Legend

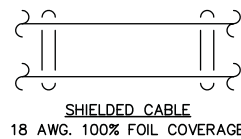
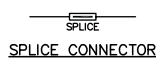
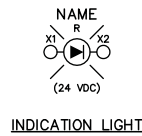
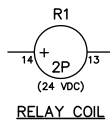
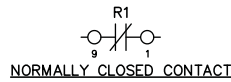
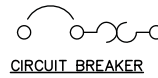
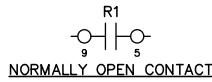
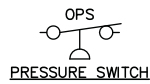
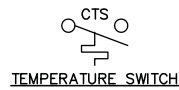
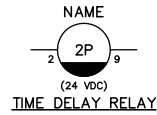
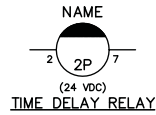

Figure 7-I. Electrical Symbol Legend

VII. MODEL 1200 POWER UNIT

VII-3. Control Pendant

A "CONTROL PENDANT" is provided to allow operation of the power unit at a distance of up to 50 feet (15 meters) and can be extended using 50 foot extension cables. The "CONTROL PENDANT" is connected to the control panel via a multiconnector plug.

The Control Pendant is particularly handy as a trouble shooting tool, in that the operator can position himself near the Control Valves while checking them. To make the Control Pendant Switches operable, turn the 'Local-Pendant' Switch to the 'Pendant' position, and the Engine Control Switch to the 'On' Position. (The Engine does not need to be running.) Each time a solenoid is energized, a pilot light on the connector to that solenoid should light up.

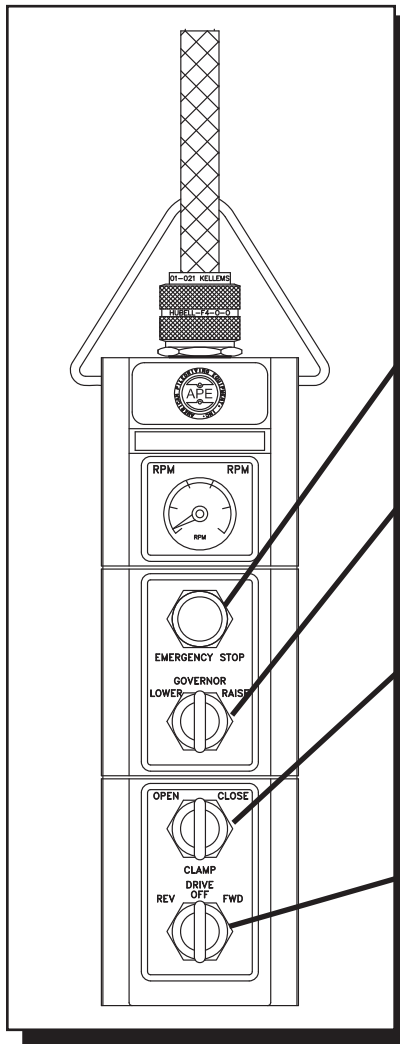

ENGINE EMERGENCY SHUTDOWN SWITCH

Press and hold to shut engine off. Do not use to shut engine off at the end of shift. Shut unit off at panel at end of shift. Button is for emergency only.

ENGINE THROTTLE SWITCH

Three position switch. Turn to raise to increase engine RPM. Turn to lower to decrease engine RPM. This switch will return to the middle position and maintain this set RPM. Use this switch increases / decreases hydraulic flow to Vibro.

CLAMP OPEN/CLAMP CLOSE

Lighted switch. Turn to close to extend jaw and clamp vibro to pile. Light comes on when clamp is closed and locked. Turn to open to retract jaw and release vibro from pile. Switch must remain in closed position to hold clamp to pile. Sometimes the light will not come on. It could be burnt out or shorted. Check clamp pressure gauge and make sure it reads at least 3800 psi before vibrating any pile. Contact APE if light is not working.

FORWARD/OFF/REVERSE

Three position switch. Turn to forward to operate vibro. Turn to off to stop vibro. Turn to reverse when using power unit to run a drill motor. Vibro is not supposed to vibrate in reverse. If it does then switch the two yellow cables labeled "drive" and "reverse" located on the other side of the control panel.

Figure 7-J. Control Pendant

WARNING: Never leave vibro clamped to a pile without the crane line attached. The clamp cylinder could bleed off causing the vibro to drop. Never hoist a pile in the air without a safety line attached to the pile. Should the clamp close line become damaged and leak, the clamp cylinder could lose pressure and drop the pile.



OPERATION / MAINTENANCE MANUAL

MODEL 400 VIBRATORY DRIVER WITH MODEL 1200 POWER UNIT

7032 SOUTH 196th - KENT, WA. 98032 - (253) 872-0141 / FAX (253) 872-8710

VII. MODEL 1200 POWER UNIT

VII-3A. Control Pendant Wiring Diagram

The following is the pin wiring configuration and the wire colors of the amphenol connectors for the remote control pendant cable.

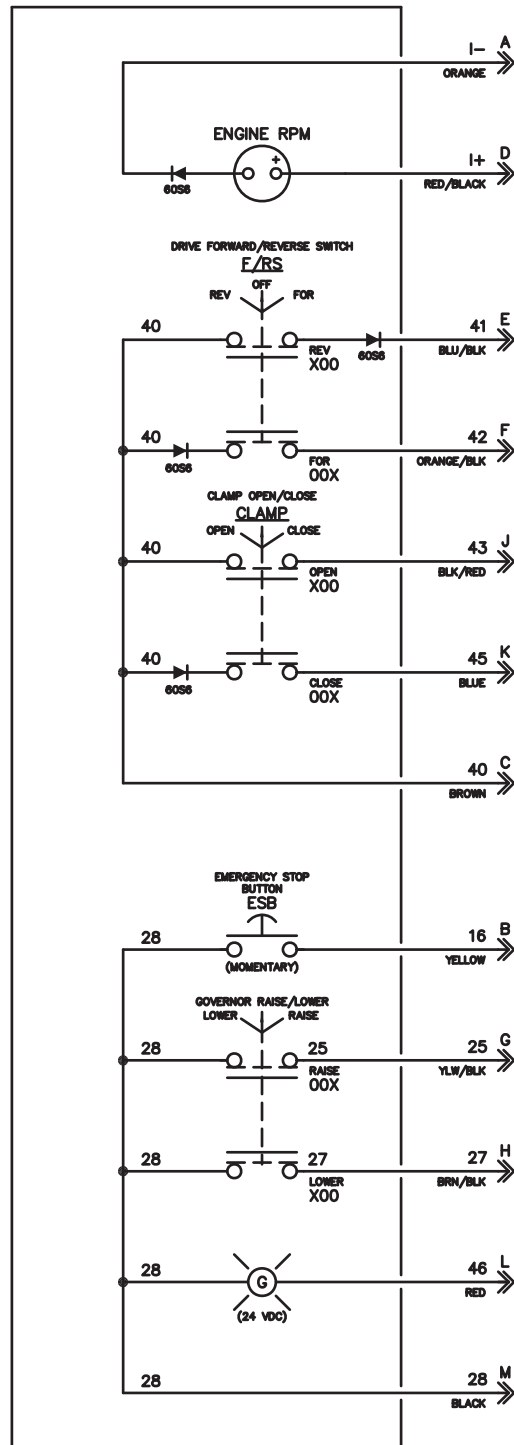

Figure 7-K. Electrical Schematic - Control Pendant



OPERATION / MAINTENANCE MANUAL

MODEL 400 VIBRATORY DRIVER WITH MODEL 1200 POWER UNIT

7032 SOUTH 196th - KENT, WA. 98032 - (253) 872-0141 / FAX (253) 872-8710

VII-4. Recommended Bolt Tightening Torque

Nominal Screw Size	Nominal Socket Size	Tightening Torque Ft-Lbs. (Kg-M)	Nominal Screw Size	Nominal Socket Size	Tightening Torque Ft-Lbs. (Kg-M)
#10-24	5/32	6 Ft-Lbs. (.83 Kg-M)	#10-32	5/32	6 Ft-Lbs. (.83 Kg-M)
1/4-20	3/16	13 Ft-Lbs. (1.8 Kg-M)	1/4-28	3/16	15 Ft-Lbs. (2.1 Kg-M)
5/16-18	1/4	27 Ft-Lbs. (3.7 Kg-M)	5/16-24	1/4	30 Ft-Lbs. (4.2 Kg-M)
3/8-16	5/16	48 Ft-Lbs. (6.6 Kg-M)	3/8-24	5/16	55 Ft-Lbs. (7.6 Kg-M)
7/16-14	3/8	77 Ft-Lbs. (10.6 Kg-M)	7/16-20	3/8	86 Ft-Lbs. (11.9 Kg-M)
1/2-13	3/8	119 Ft-Lbs. (16.4 Kg-M)	1/2-20	3/8	133 Ft-Lbs. (18.4 Kg-M)
5/8-11	1/2	234 Ft-Lbs. (32.3 Kg-M)	5/8-18	1/2	267 Ft-Lbs. (36.9 Kg-M)
3/4-10	5/8	417 Ft-Lbs. (57.6 Kg-M)	3/4-16	5/8	467 Ft-Lbs. (64.5 Kg-M)
7/8-9	3/4	676 Ft-Lbs. (93.4 Kg-M)	7/8-14	3/4	742 Ft-Lbs. (102.5 Kg-M)
1-8	3/4	1,009 Ft-Lbs. (139.4 Kg-M)	1-12	3/4	1,126 Ft-Lbs. (155.6 Kg-M)
1-1/4-7	7/8	1,600 Ft-Lbs. (221.1 Kg-M)	1-1/4-12	7/8	1,800 Ft-Lbs. (248.8 Kg-M)
1-1/2-6	1	2,800 Ft-Lbs. (387 Kg-M)	1-1/2-12	1	3,000 Ft-Lbs. (414.6 Kg-M)

Table 7-F. Recommended Bolt Tightening Torque

NOTE: These values are for Socket head cap screws only. Button heads, Flat heads and Set screws have different values. Check the Allen Hand Book for correct torque specifications.