



**MODEL 200
BOTTOM DRIVE
WICK INSERTER**

OPERATING AND MAINTENANCE MANUAL

MODEL 200 WICK

BOTTOM DRIVE WICK INSERTER

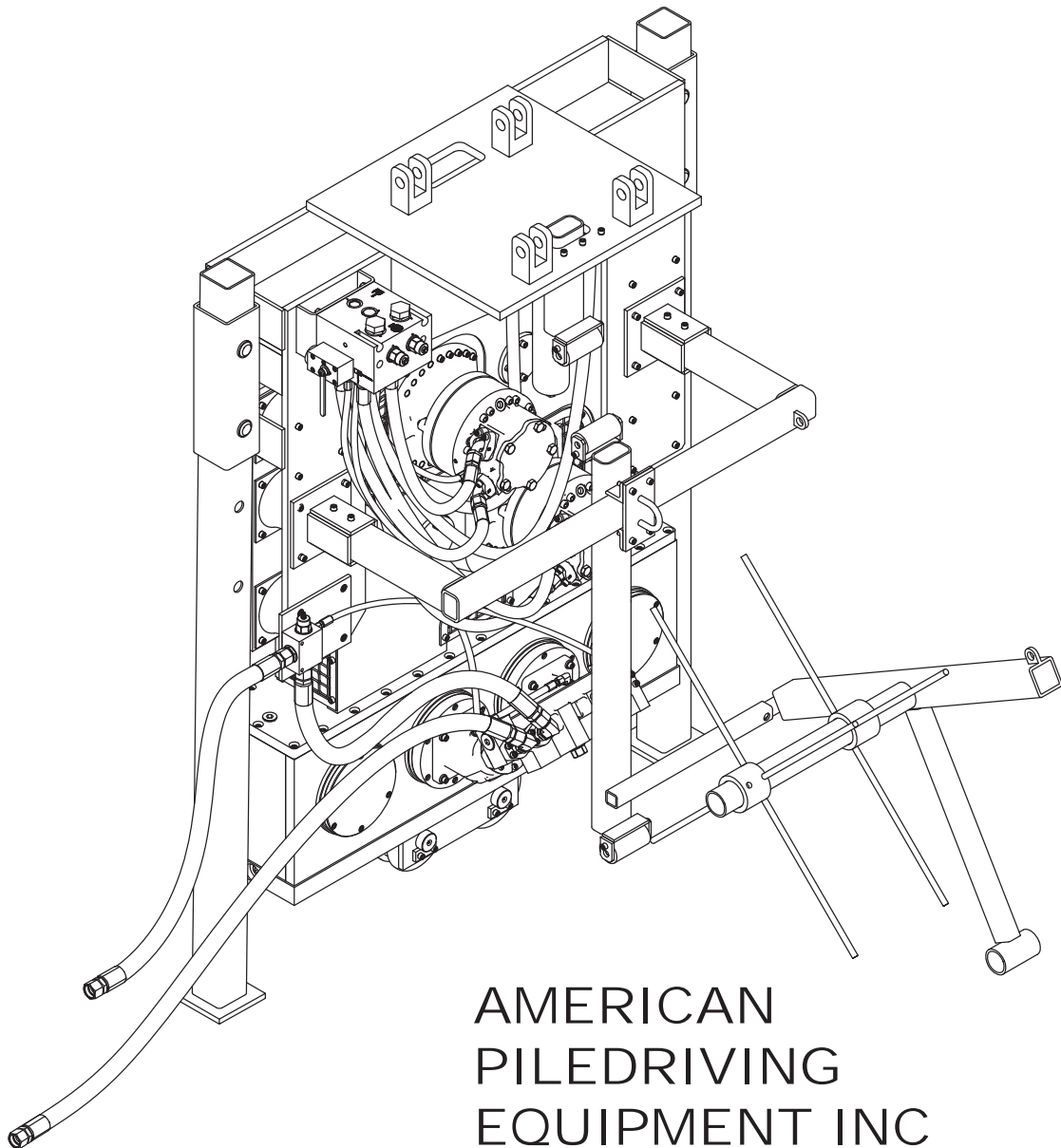

**AMERICAN
PILEDIVING
EQUIPMENT INC**

MAN 200 WICK 201501



**MODEL 200
BOTTOM DRIVE
WICK INSERTER**

Revision Record

Change Number	Page Number	Date	Revision Description
		01-2015	Initial Printing
		10-2018	Added Wick Drain Mandrel Splice Specifications



**MODEL 200
BOTTOM DRIVE
WICK INSERTER**

APE MODEL 200 BOTTOM DRIVE
WICK INSERTER
MAN 200 WICK-201501

PREFACE

INFORMATION This manual was prepared to acquaint the owner, operator and serviceman with the operation and maintenance of the vibratory driver/extractor. We strongly suggest that this manual be carefully studied before operating or undertaking any maintenance work on the unit. It is not meant to be all inclusive as to content, and any questions and/or doubt should be directed to APE before proceeding with any operation or maintenance.

This manual is organized into two major categories.

The first category is for OPERATING INSTRUCTIONS of the unit and includes a GENERAL DESCRIPTION section, which presents a basic explanation of the driver/extractor specifications. The MAINTENANCE AND ADJUSTMENT section should be referred to for all servicing of equipment. All machines and equipment require systematic, periodic inspection and maintenance, if they are to perform satisfactorily.

The second category is for parts ordering and it includes both a PARTS LIST and a pictorial drawing of the assembly. Refer to the ORDERING PARTS section of the PARTS LIST for more specific procedures regarding parts ordering. Adherence of the listed procedures will insure receipt of the required part(s) with the minimal amount of delay or error.

APE reserves the right to update or revise this manual as required, check with APE for current release date.



**MODEL 200
BOTTOM DRIVE
WICK INSERTER**



**MODEL 200
BOTTOM DRIVE
WICK INSERTER**

Warranty

American Piledriving Equipment, Inc. J&M Foundation Equipment LLC
STANDARD WARRANTY

American Piledriving Equipment, Inc./J&M Foundation Equipment LLC (APE/J&M) warrants new products sold by it to be free from defects in material or workmanship for a period of one year after the date of delivery to the first user and subject to the following conditions:

APE/J&M's obligation and liability under this WARRANTY is expressly limited to repairing or replacing at APE/J&M's option, any parts which appear to APE/J&M upon inspection to have been defective in material or workmanship. Such parts shall be provided at no cost to the user, at the business establishment of APE/J&M or the authorized APE/J&M distributor of the product during regular working hours. This WARRANTY, shall not apply to component parts or accessories of products not manufactured by APE/J&M and which carry the warranty of the manufacturer thereof, or to normal maintenance (scraped and scived lube and fuel lines, worn cushion material in the drive base) or normal maintenance parts (such as fouled injectors, weakened check valve springs, damaged grease zirts caused by use over time).

Replacement or repair parts installed in the product covered by this WARRANTY are warranted only for the remainder of the warranty as if such parts were original components of said product. APE/J&M makes no other warranty, expressed or implied and makes no warranty of merchantability of fitness for any particular purpose.

APE's obligation under this WARRANTY shall not include any transportation charges, costs of installation, duty, taxes or any other charges whatsoever, or any liability for direct, indirect, incidental or consequential damage or delay. If requested by APE/J&M, products or parts for which a warranty claim is made are to be returned transportation prepaid to APE/J&M. Any improper use, including operation after discovery of defective or worn parts, operation beyond rated capacity, substitution of any parts whatsoever, or parts not approved by APE/J&M or any alteration or repair by others in such manner as in APE/J&M's judgment affects the product materially and adversely, shall void this warranty.

**ANY TYPE OF WELDING ON EQUIPMENT
WILL VOID THE WARRANTY**

Refusal: Vibros: If the pile does not move one foot in 30 seconds of vibro operation at full speed. Resort to a larger vibro. APE/J&M equipment may exceed the refusal driving criteria for short periods of time as may be needed to penetrate hard soil layers or obstacles. In such cases, a heat gun is used to monitor the temperature of the bearings and related components to prevent use of the machine beyond 190 degrees. Contact APE/J&M or your local APE/J&M distributor for special instructions when faced with refusal conditions.

Refusal: Diesels: Do not exceed 10 blows per inch or 120 blows per foot. In cases of setting of the pile it is permitted to increase the blow count to 250 blows per foot, but only for one foot of driving penetration. Pile inspectors should consult the APE factory for permission to exceed these limits. Failure to do so will void the warranty. This standard specification is accepted by the DFI (Deep Foundations Institute) and the PDCA

(Pile Contractors Association) and by all manufacturers of pile driving equipment.



**MODEL 200
BOTTOM DRIVE
WICK INSERTER**

TABLE OF CONTENTS

<u>I.</u>	<u>GENERAL DESCRIPTION</u>	<u>PAGE</u>
A.	General	I- 1
B.	Vibration Gear Box	I- 2
C.	Vibration Suppressor	I- 2
D.	Wick Carrier	I- 2
E.	Mandrel Guide	I- 2
F.	Legs	I- 2
G.	Leader System	I- 2
H.	Specifications	I- 3
<u>II.</u>	<u>PREPARATION FOR OPERATION</u>	
A.	General	II- 1
B.	Safety Precautions	II- 1
C.	Rigging of Vibrator	II- 3
D.	Connection of Hydraulic Hoses	II- 4
E.	Filling Vibrator Pressure Hose	II- 5
<u>III.</u>	<u>OPERATING INSTRUCTIONS</u>	
	—Feroy Selector Valve	III- 1
A.	Completion of Set-Up and Maintenance	III- 2
B.	Feroy Selector Valve	III- 2
C.	Driving / Extracting Mandrel	III- 2
D.	Changing Frequency	III- 3
E.	Shut Down	III- 3
<u>IV.</u>	<u>MAINTENANCE AND ADJUSTMENTS</u>	
A.	General	IV- 1
B.	Daily	IV- 1
C.	100 Hours, 500 Hours and Other	IV- 2
D.	Severe Conditions	IV- 2
E.	Lubrication	IV- 3
F.	Bolt Torque Information	IV- 5



**MODEL 200
BOTTOM DRIVE
WICK INSERTER**

TABLE OF CONTENTS

	<u>PAGE</u>
V. <u>HYDRAULIC CIRCUITRY</u>	
A. Vibrator Drive	V- 1
Hydraulic Schematic	V- 2
B. Hydraulic Components List	V- 3
VI. <u>GENERAL DATA</u>	
A. Abbreviations	VII- 1
B. Screws and Bolts	VII- 1
C. Serial Number Locations	VII- 2
VII. <u>ORDERING PARTS</u>	
A. Procedure	VII- 1
B. Fitting Description Key	VII- 2
Fitting Style Selector Chart - SC1	VII- 3
C. Hose Description Code	VII- 4
D. Parts Identification	VII- 5
Parts Lists and Drawings	VII- 6
E. Miscellaneous Accessories	VII- 30
F. Recommended Spare Parts	VII- 31
G. Recommended Tightening Torque	VII- 32



**MODEL 200
BOTTOM DRIVE
WICK INSERTER**



**MODEL 200
BOTTOM DRIVE
WICK INSERTER**

**OPERATING
INSTRUCTIONS**

A. GENERAL

The APE Model 200 BOTTOM DRIVE WICK INSERTER is a vibratory wick drain inserter. Designed to insert wick drain by forcing a wick threaded mandrel into wet soil while vibrating through tough soil.

The Model 200 Wick operates in a frequency range of 800 to 1,650 vibrations per minute to provide maximum mandrel penetration rates in a wide variety of soils. Produces 56 tons (498 kN) of dynamic force and 27.8 tons (247 kN) of static driving force.

The wick inserter unit consists of six major components. (1) The vibration gear box, (2) the vibration suppressor which contains mandrel control motors, (3) the wick carrier assembly, (4) the leg assembly, (5) mandrel guide and (6) the lead system (not shown).

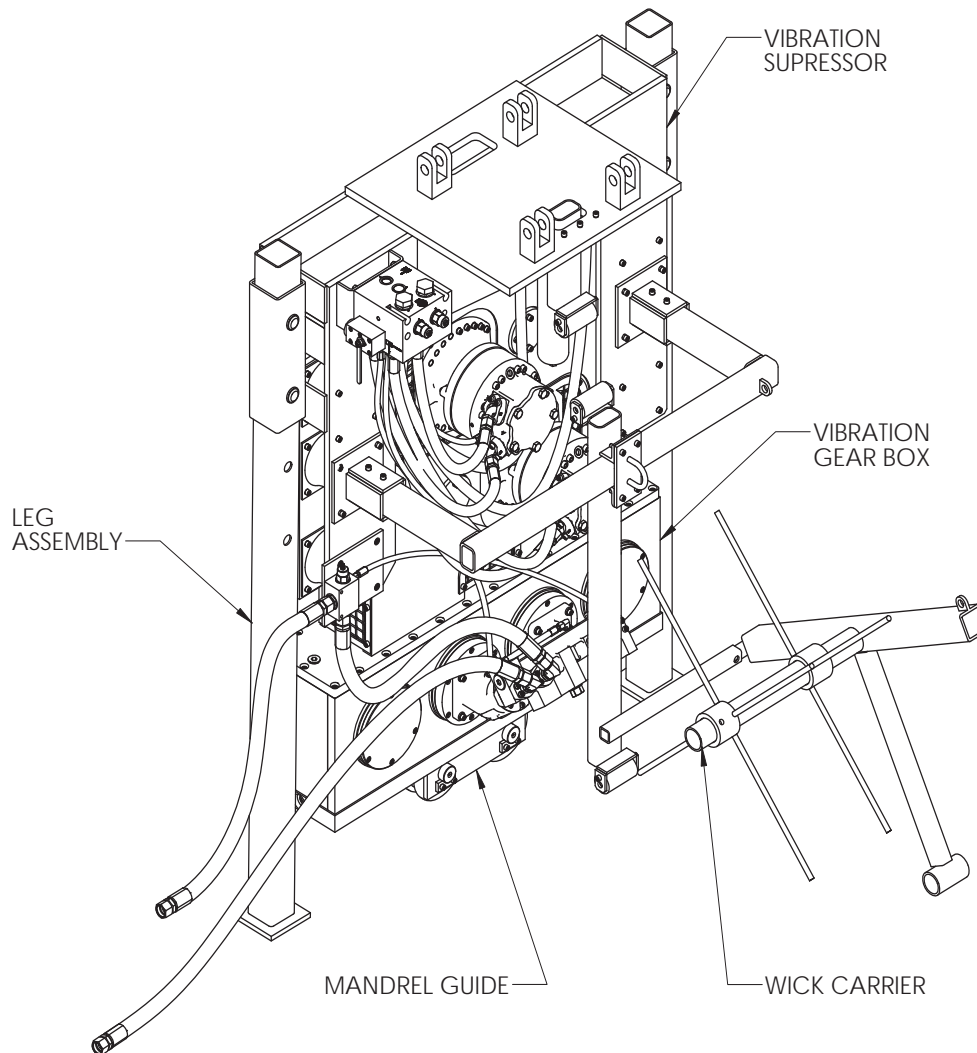

Fig. 1-1



**MODEL 200
BOTTOM DRIVE
WICK INSERTER**

**OPERATING
INSTRUCTIONS**

I. GENERAL DESCRIPTION

B. VIBRATION GEAR BOX

The vibration gear box contains two eccentric weights which rotate in a vertical plane to create vibration (Dynamic Force). The eccentric weights are driven by a hydraulic motor.

C. VIBRATION SUPPRESSOR

The vibration suppressor contains 12 rubber elastomers to isolate the vibration case from the leads. The mandrel insert / extract motors are mounted here. A pair of hydraulic motors with a sprocket assembly mounted to the motors force the mandrel into the ground as well as removing the mandrel from the ground. There is a roller assembly that works together with the sprockets keeping the mandrel engaged with the sprockets.

D. WICK CARRIER

The wick carrier assembly is designed to carry six spools of wick drain. This assembly has capability to hold one spool on the center of the wick tube and five to the side of center of the wick tube. While you line-up the first spool of wick to the wick tube the rest of the carrier can hold the spare spools of wick. When the center spool is close to being empty mechanically join the end of the wick to the beginning of a new spool of wick. When the center spool is empty, remove spool bracket and wick roll tube. Re-install spool bracket, slide the wick spools so that the first spool is in-line with the wick tube and slide the other spool bracket over to keep the remaining wick spools in place. Continue to mechanically joining the end of a spool to the beginning of the next spool and adjusting the spool bracket.

E. MANDREL GUIDE

The mandrel guide is a set of rollers at the bottom of the vibration case used to maintain position of the mandrel fore and aft as well as right and left. The mandrel is a rectangular steel tube that is used to thread the wick drain into the soil.

F. LEGS

The legs are to rest upon the ground to stabilize the wick inserter while inserting wick or removing the mandrel. They are adjustable to suit the job site and operators preference of height for best visibility.

G. LEADER SYSTEM

The leader system is a lattice system used to support and guide the mandrel and wick drain. This system has a trough for the mandrel to run in maintaining it's location in relationship to the wick inserter assembly. A set of lugs and pins connect the leader system together as well as the leader system to the inserter assembly. On top of the leader system is a wick guide bracket that aligns the wick drain that goes to the top of the leader system and over to top of the mandrel.



MODEL 200 BOTTOM DRIVE WICK INSERTER

OPERATING INSTRUCTIONS

I. GENERAL DESCRIPTION

H. SPECIFICATIONS

1. Constant improvement and engineering progress make it necessary that we reserve the right to make specification changes without notice.

Always consult APE in your area for current or additional information you may require.

2. Model 200 Bottom Drive Wick Inserter

Type	Hydraulic
Frequency	1000-1650 VPM
Max Dynamic Force	56 Tons (498kN)
Static (Crowd) Force	27.8 Tons (247kN)
Weight	10,780# lbs. (4,889 kg)
Length [L]	85.26 in. (216.6 cm)
Width [W]	46.26 in. (117.5 cm)
Whole Width [WW]	86.35 in. (219.3 cm)
Height [H]	112.38 in. (285.4 cm)

INFORMATION

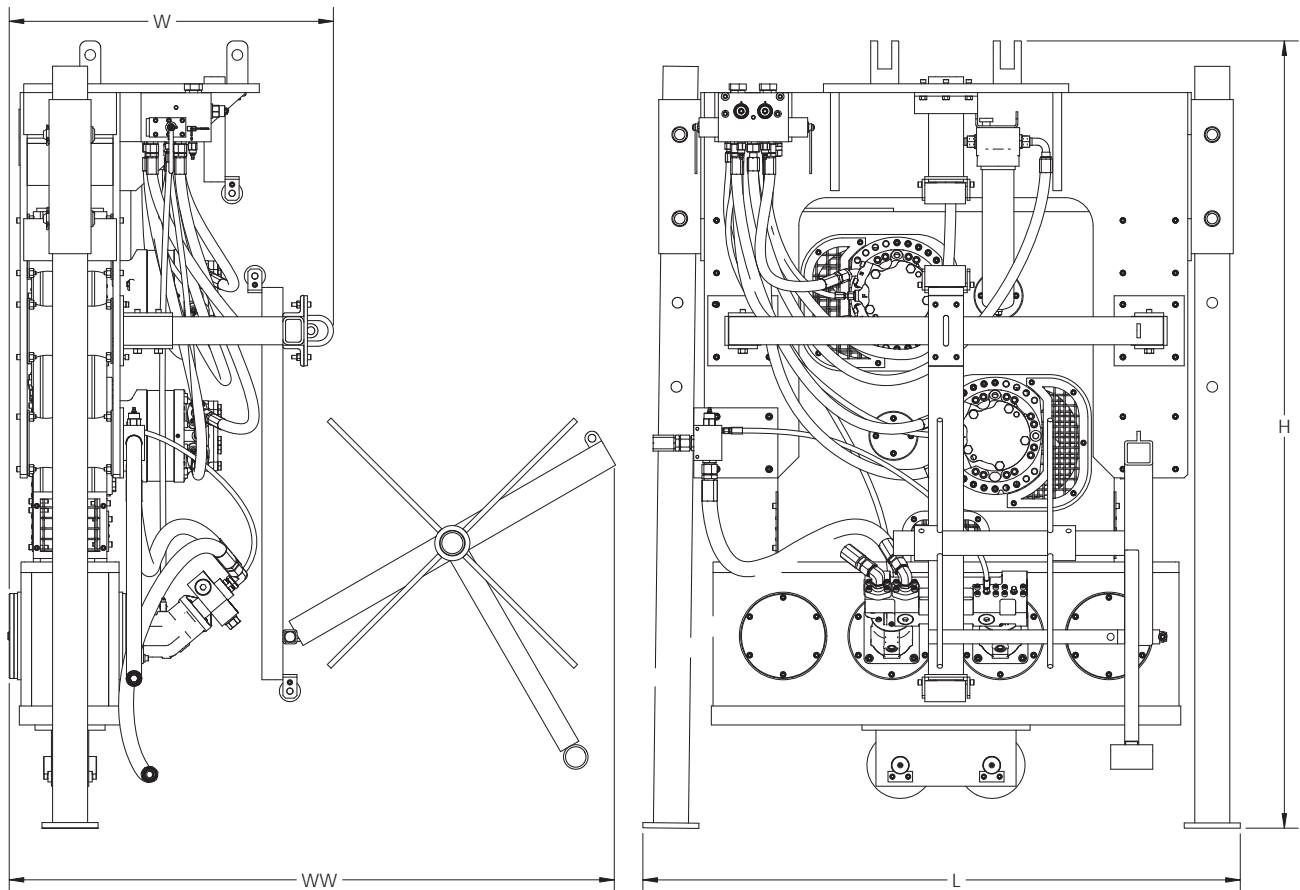

Fig. 1-2



**MODEL 200
BOTTOM DRIVE
WICK INSERTER**

OPERATING INSTRUCTIONS



**MODEL 200
BOTTOM DRIVE
WICK INSERTER**

OPERATING INSTRUCTIONS

II. PREPARATION FOR OPERATION

A. GENERAL



When unloading and unpacking the bottom drive wick inserter, use extreme care. For your protection, make a thorough inspection of the unit immediately on delivery. In case of any damage or shortage, notify the transit agent at once and have the delivering carrier make a notation on the freight bill.

B. SAFETY PRECAUTIONS

Safety is very important and is everyone's responsibility that operates this equipment or services this equipment.



Use the following safety precautions as a general guide to safe operations, when in doubt consult APE before proceeding with any operation that may produce an unsafe result. These safety guidelines do not constitute all possible safety issues that may occur during operation or maintenance.

1. Read this manual thoroughly before operating or working on the equipment.
2. Read and follow any safety instructions in the excavator's operators manual.
3. Only well trained and experienced personnel should attempt to operate or maintain this equipment.
4. Never adjust, lubricate or repair the unit when it is in operation, or lifted above ground level.
5. Never remove, paint over or cover warning or safety labels. If labels become damaged or unreadable, replace immediately.
6. All personnel should wear approved safety clothing, including **HARD HATS, SAFETY SHOES, SAFETY GLASSES** and **HEARING PROTECTION** when in the vicinity of this machinery.
7. Do not stand any closer to this equipment than necessary when it is in operation. Parts may loosen and fall. Never stand under operating, or elevated, equipment.
8. When maintaining or repairing the equipment, never substitute parts not supplied, or approved in writing, by APE.
9. Do not weld, or flame cut, on this equipment.
10. Never use or store flammable liquids on or near the engine.
11. Insure that all lifting equipment, including cranes, wire rope, slings, hooks, shackles, etc., are properly sized for the worst case loads anticipated during operations.
12. If there are any questions about the weights, specifications, or performance of the unit, contact APE before handling or operating the equipment.
13. If the equipment is to be used for anything other than inserting plumb wick drains, contact APE before using the unit.



**MODEL 200
BOTTOM DRIVE
WICK INSERTER**

OPERATING INSTRUCTIONS

II. PREPARATION FOR OPERATION

B. SAFETY PRECAUTIONS (CONTINUED)

14. Insure that ground vibrations will not damage or collapse adjacent structures or excavations.
15. Remove all tools, parts and electrical cords before starting the unit.
16. When operating in an enclosed area, pipe exhaust fumes outside. Continued breathing of exhaust fumes may be fatal.
17. When servicing batteries, do not smoke or use open flames in the vicinity. Batteries generate explosive gas during charging. There must be proper ventilation when charging batteries.
18. When filling fuel tank, do not smoke or use open flame in the vicinity.
19. If abnormal equipment operation is observed, discontinue use immediately and correct the problem.
20. Do not adjust, or set, hydraulic pressures higher or lower than those specified in this manual.
21. Never operate this equipment with hydraulic hoses that are damaged or "kinked". Replace damaged hoses immediately.
22. Do not lift, or support, hydraulic hoses with wire rope slings.
23. Do not pull on, or attempt to move equipment, with hydraulic hoses.
24. Do not attempt to locate hydraulic leaks with your hands. High pressure hydraulic leaks can penetrate the skin, causing severe damage, blood poisoning and infection. Do not attempt to repair leaks while the equipment is in operation.
25. Do not attempt to tighten, or loosen, fittings or hoses when the machine is in operation.
26. A properly maintained fire extinguisher, suitable for oil fires, must be kept in the immediate vicinity of equipment operations.
27. When moving or transporting this equipment, insure that the vehicle or vessel is of sufficient capacity to handle the load, and that the equipment is properly tied down.
28. Be sure that all equipment parts are tight, or properly secured, before shipment. Unsecured parts may vibrate loose and fall, during transport, causing injury or property damage.
29. Keep crane boom, mandrel, lead system, wire rope and other equipment at least 15' (5M) from electrical power lines, transformers and other electrical equipment, or at such distance as required by applicable safety codes.



**MODEL 200
BOTTOM DRIVE
WICK INSERTER**

**OPERATING
INSTRUCTIONS**

II. PREPARATION FOR OPERATION

B. SAFETY PRECAUTIONS (CONTINUED)

30. Rounded or damaged bolt heads or nuts should be replaced so that proper torque values may be obtained. Proper torque values are necessary to prevent parts on this equipment, leads and crane boom from loosening and falling. Refer to Torque Chart, in this manual, for proper values.
31. Never induce mandrel crowd or extraction force before starting the unit in vibration. Always start both driving and extraction of mandrel insertion / extraction circuit in neutral.
32. Keep hands away from mandrel sprocket assemblies.
33. Keep hands away from vibrator suppressor during operation. Clearances may change causing pinch points.
34. When driving "batter" wick drain insure that the lead system, and crane boom, have sufficient bending strength to handle the worst case load. Consult APE.

REMEMBER, SAFETY IS EVERYONE'S BUSINESS.

C. RIGGING OF INSERTER

A mast system is designed to mount to the base rig that the Bottom Drive Wick Inserter is mounted to that also guides the Mandrel with the wick. The following instructions provide guidelines for the assembling.

An adapter has been designed for the entire assembly for the original project to a certain excavator.

1. With Mast in horizontal position bolt the lower two wick lead sections to mast.
2. Stand mast vertical.
3. Pin bottom drive wick inserter to wick lead.
4. Lower mast to horizontal.
5. Pin upper sections of wick lead to the lower sections that are bolted to the mast.
6. Supporting and hanging mandrel load into the bottom of bottom drive wick inserter using Roller Guide Asm.
7. With the BV1 motor valve in the "FREE WHEEL" position and the needle valve (NV1) closed all but one turn open.
8. Slowly pull the lever in the extract wick position to allow the bottom motor sprocket to pull the mandrel into the mast.
9. The mandrel will engage into the upper motor sprocket. You can continue to feed the mandrel as is.
10. With BV1 turned to the "RUN" position and the NV1 open all the way feed the remainder of the mandrel.

The pins supplied for the mast are the only pins to be used and installed with supplied fastening hardware.



**MODEL 200
BOTTOM DRIVE
WICK INSERTER**

**OPERATING
INSTRUCTIONS**

II. PREPARATION FOR OPERATION

D. CONNECTION OF HYDRAULIC HOSES

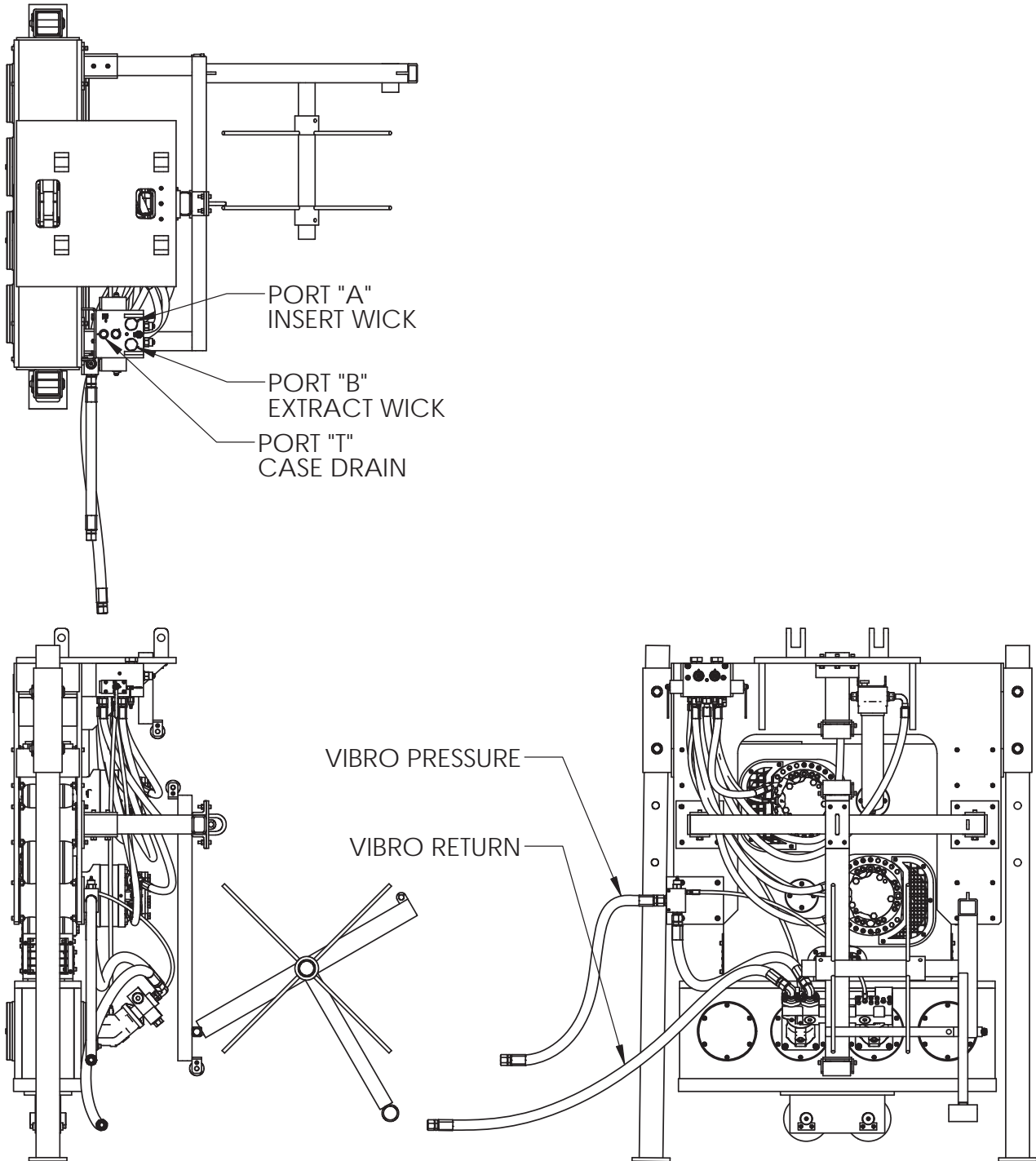

Fig. 2-1



**MODEL 200
BOTTOM DRIVE
WICK INSERTER**

OPERATING INSTRUCTIONS

II. PREPARATION FOR OPERATION

C. RIGGING OF INSERTER (CONTINUED)

The mandrel can be loaded in the lengths of delivery and welded together as the end of the mandrel nears the Roller Guide Asm. Another way to load the mandrel is to completely weld the entire length in advance. Either way it is a must to use the Mandrel Template p/n 352017 to align and properly space the sections.

All rigging of either the inserter must be done in accordance with standard rigging guide lines set forth in ASTM standards; APE does not assume responsibility for incorrect rigging or procedures.

D. CONNECTION OF HYDRAULIC HOSES (CONTINUED)

1. Connection of hoses inserter.

a. The inserter gear box motor and crowd / extraction motors are connected to the base rig by five hydraulic hoses (Fig. 2-1) on the previous page.



The base rig must be shut down during connection of the hydraulic hoses.

b. Clean connection fittings with a lint-free cloth before making connections.

c. Make sure that the connectors are fully tightened with wrenches.

2. Connection of hoses at base rig.

a. The vibrator circuit is controlled by the tool circuit.



Use caution when bleeding any hydraulic lines, even low hydraulic pressure can cause injury to personnel.



**MODEL 200
BOTTOM DRIVE
WICK INSERTER**

OPERATING INSTRUCTIONS

II. PREPARATION FOR OPERATION

E. FILLING VIBRATOR PRESSURE HOSE

1. The vibrator is usually shipped with the vibrator hydraulic hoses full of fluid and the unit may be used immediately. However, if the pressure hose has been removed from the vibrator, the hose should be allowed to fill with hydraulic fluid prior to full speed operation.
2. Read SECTION III - OPERATING INSTRUCTIONS.
3. Start and warm up the diesel engine in accordance with SECTION III-C - STARTING AND WARMING UP ENGINE. Hold the vibrator in a vertical position.
4. With the engine warmed up and running at 1000 RPM, turn and hold the vibrator switch REVERSE. The hoses will fill in approximately 5 minutes.



If vibration begins in the vibrator, stop immediately and recheck hose connections.



**MODEL 200
BOTTOM DRIVE
WICK INSERTER**

OPERATING INSTRUCTIONS

III. OPERATING INSTRUCTIONS

A. COMPLETION OF SET-UP AND MAINTENANCE

1. Complete all preparation as described in Section II.
2. Read Section IV - MAINTENANCE AND ADJUSTMENTS and perform any required maintenance.

B. ERECTING MAST - LEAD SYSTEM

Raising the Mast:

1. The mast is raised by pushing the "LEADER ERECT" lever, this lever is on the far right and the knob is Black.
2. The mast will rise to about 30 degrees from horizontal and the limit switch will stop movement, an alarm will sound.
3. Pull the "WINCH-MAIN" lever, this lever is the second from the right and the knob is Red.
4. The mast will be hoisted bringing the base rearward until it stops the alarm will stop. This has released the limit switch.
5. Push the "LEADER ERECT" lever until the mast is in full vertical position.

CAUTION

Adjustment of the mast - lead system should only be done when NO mandrel is below the surface of soil.

Lowering the Mast:

1. The mast is lowered by pulling the "LEADER ERECT" lever, this lever is on the far right and the knob is Black.
2. The mast will lower until about 30 degrees from horizontal and the limit switch will stop movement, an alarm will sound.
3. Push the "WINCH-MAIN" lever, this lever is the second from the right and the knob is Red.
4. The mast will be lowered bringing the base forward until it stops the alarm will stop. This has released the limit switch.
5. Pull the "LEADER-ERECT" lever until the mast is completely down resting in the mast cradle. In the case that the operator wants to lower the mast into the cradle slower there is a toggle switch. Pull and hold the toggle switch labeled "SUPER SLOW" all the while pulling the "LEADER-ERECT" lever.

Attention: All fully assembled rig movement is to be done with mast in the full vertical position!



**MODEL 200
BOTTOM DRIVE
WICK INSERTER**

OPERATING INSTRUCTIONS



**MODEL 200
BOTTOM DRIVE
WICK INSERTER**

OPERATING INSTRUCTIONS

III. OPERATING INSTRUCTIONS

C. DRIVING / EXTRACTING MANDREL

Pushing the “WINCH-AUX” lever, this lever is the third from the right and is the knob is Blue. Pushing and holding the lever a small amount will allow the mandrel to move down slowly. The further the lever is pushed the faster the mandrel will move.

Returning the lever to the neutral position stops the mandrel.

Pulling the “WINCH-AUX” lever, this lever is the third from the right and is the knob is Blue. Pulling and holding the lever a small amount will allow the mandrel to move up slowly. The further the lever is pushed the faster the mandrel will move.

There is an indicator at the top of the mandrel. This indicator allows the operator and crew to know how far the mandrel is in the ground by how much is above the bottom drive wick inserter. This indicator is especially useful to determine how much mandrel is left in the ground when extracting the mandrel. The crew and operator must keep in mind that the mandrel will not stop based on the position the mandrel. The mandrel will smash out the top roller if the mandrel is not stopped before this happens.

D. RUNNING THE VIBRO (BOTTOM DRIVE WICK INSERTER)

When the mandrel slows or stops running into the ground using the mandrel inserting motors the use of the vibros is needed. A good indicator that the driving of the mandrel is getting tough the gear case will be pushed up into the suppressor. It is recommended that when you see this happen push and hold the “VIBRO” button. Within a few seconds the Vibro will begin to vibrate at full speed. With Vibro running at full speed continue to run the mandrel. If you wait until the mandrel stops release the WINCH AUX lever and push and hold the “VIBRO” button. With Vibro running at full speed continue to run the mandrel. When the tough soil layer is broken through release the “VIBRO” button while continuing to run the mandrel.

G. SHUT DOWN

1. Stop the vibration gear box and mandrel drive motors.
2. Allow the diesel engine to run for five minutes at 1500 RPM.
3. Reduce speed to low idle for about thirty seconds.
4. Stop the engine by turning the ENGINE START switch to OFF.



**MODEL 200
BOTTOM DRIVE
WICK INSERTER**

OPERATING INSTRUCTIONS



**MODEL 200
BOTTOM DRIVE
WICK INSERTER**

OPERATING INSTRUCTIONS

IV. MAINTENANCE AND ADJUSTMENTS

A. GENERAL

Preventive maintenance includes normal servicing that will keep the wick inserter in peak operating condition and prevent unnecessary trouble from developing. This servicing consists of periodic lubrication and inspection of the moving parts and accessories of the unit.

Lubrication is an essential part of protective maintenance, controlling to a great extent the useful life of the unit. Different lubricants are needed and some components in the unit require more frequent lubrication than others. Therefore, it is important that the instructions regarding types of lubricants and frequency of their applications be closely followed.

To prevent minor irregularities from developing into serious conditions that might involve shut-down and major repair, several other services or inspections are recommended for the same intervals as the periodic lubrications. The purpose of these services or inspections is to assure the uninterrupted operation of the unit.

Thoroughly clean all lubrication fittings, caps, filler and level plugs and their surrounding surfaces before servicing. Prevent dirt from entering with lubricants and coolants. The intervals given in the schedule are based on normal operation. Perform these services, inspections, etc., more often as needed for operation under abnormal or severe conditions.

B. DAILY

1. Check the entire unit prior to and during set-up each day or at the beginning of each shift.
2. Prior to starting the engine of the base rig or at the beginning of each shift, check the following items:
 - a. Visibly inspect all bolts, nuts and screws, to insure they are tight.

▲ CAUTION Vibration loosens bolts - check carefully.

- b. Check the oil level in the vibration gear box and add oil if required. The oil level should be in the middle of the sight glass. Change oil if milky or contaminated. DO NOT OVERFILL

▲ CAUTION It is absolutely imperative that no dirt or other impurities be permitted to contaminate the hydraulic fluid. Any contamination will drastically shorten the life of the high-pressure hydraulic system.



**MODEL 200
BOTTOM DRIVE
WICK INSERTER**

OPERATING INSTRUCTIONS

IV. MAINTENANCE AND ADJUSTMENTS

B. DAILY (CONTINUED)

- c. Visually check all hoses for signs of damage or cuts that might cause hose failure during operation. Be sure all connections are tight.
 - d. Visually inspect all suppressor elastomers and elastomer bolts.
 - e. Grease the rollers in the mandrel guide assemblies and the rollers in the roller guide assembly.
 - f. Perform all daily maintenance checks and lubrication indicated in the base rig's OPERATION GUIDE.
3. After engine start-up, check the following:
- a. Check all hydraulic hoses for leaks. Make sure they hang freely with no kinks.
 - b. Check hydraulic manifolds for leaks.

C. 75 HOURS AND OTHER

1. Every 75 hours, drain and add new lubricant in the vibration gear box.
2. Perform all maintenance checks and lubrication indicated in the base rig's OPERATION GUIDE.

D. SEVERE CONDITIONS

The servicing intervals specified are based on normal operating conditions. Operation under severe or unusual conditions will require some adjustments in servicing intervals.

1. When the average temperature is above 80°F(26°C) or below -10°F(-23°C), reduce service time intervals by one-half of those specified above.
2. When operating in the presence of dust or sand, reduce service time intervals by one-half of those specified.
3. When operating in excess of twelve hours per day, reduce service time intervals by one-half of those specified.
4. When operating in air with high moisture or salt, the servicing intervals need not usually be changed. However, the unit should be inspected weekly to determine if additional servicing be required. Also, have hydraulic fluid tested quarterly.



**MODEL 200
BOTTOM DRIVE
WICK INSERTER**

OPERATING INSTRUCTIONS

IV. MAINTENANCE AND ADJUSTMENTS

E. LUBRICATION

1. Hydraulic System

To maintain the maximum operating efficiency in the precision parts of the hydraulic system, it is extremely important to eliminate factors which can cause breakdowns or unsatisfactory performance in the system. Among the most common of these factors are rust, corrosion, contamination and products of oil deterioration. Most problems can be minimized or avoided simply by maintaining a disciplined preventive maintenance program.

Some simple steps to follow as part of that program are:

- a. Keep stored oil dry and clean at all times and always store in clean containers.
- b. Always clean tools, spouts, lids, funnels, etc. when used in conjunction with the transfer of oil.
- c. Never put dirty oil into the hydraulic system. Use only clean, uncontaminated oil. Never return to the system any fluid which has leaked out.

NOTE: Foreign material in the hydraulic system can drastically effect the life and operation of many hydraulic component parts.

- d. Clean or replace filter elements at the first indication that they are dirty or ineffective.

2. Vibration Gear Box

The fluid level is easily read through the sight glass located at the lower center of the vibration case on the motor side. Lubricating oil may be added when necessary, through the hole in the vibration case top plate after removing the 1" pipe plug. To drain the case, remove a 1" pipe plug at the end of the base plate. Tilt the case for complete drainage. The capacity of gear oil is 20 quarts.



**MODEL 200
BOTTOM DRIVE
WICK INSERTER**

OPERATING INSTRUCTIONS



**MODEL 200
BOTTOM DRIVE
WICK INSERTER**

**OPERATING
INSTRUCTIONS**

IV. MAINTENANCE AND ADJUSTMENTS

E. LUBRICATION (CONTINUED)

3. The preferred lubricating oil for APE vibration gear boxes is “High Moly” oil (Schaeffer 268).
 - a. The vibration gear box lubricant installed at the factory is SCHAEFFER 268 but the following gear lubes may be used when changing lubricants:

FIRST Preference Group:

SCHAEFFER 268

SECOND Preference Group:

MOBIL	SHC 629
BORON	Gearep 140
CHEVRON	Gear Comp. NL460
CITGO	Premium MP 85W-140
CITGO	Standard MP 85W-140

THIRD Preference Group (Natural Petroleum Base):

AMOCO	Perma Gear EP140
ARCO	Pennant NL 460
CONOCO	EP 460
EXXON	Spartan EP 460
PHILLIPS	AP 140

SCHAEFFER 268 Lubricant is available from APE in five gallon cans.

F. BOLT TORQUE INFORMATION

Torque, in foot-pounds, is determined by the length of the wrench handle (in feet) multiplied by the weight (or force in pounds) applied at the end of the handle. For example, if the wrench is one foot long and five pounds of force is applied at the end of the handle, the total torque applied would be five foot pounds. A six inch wrench would require ten pounds of force to obtain five foot pounds of torque.

The only way to actually tighten high strength bolts is with a torque wrench. Proper use of the torque wrench is important. To obtain the listed torques, a steady pull should be exerted to the handle until the desired torque is reached.



**MODEL 200
BOTTOM DRIVE
WICK INSERTER**

OPERATING INSTRUCTIONS



**MODEL 200
BOTTOM DRIVE
WICK INSERTER**

**OPERATING
INSTRUCTIONS**

V. HYDRAULIC CIRCUITRY

A. VIBRATOR DRIVE

With the diesel engine running at full RPM hydraulic oil from the circuit is to run the vibro motors.

Pushing and holding the “VIBRO” button sends hydraulic oil to the VIBRATOR MOTORS (M3 & M4).

Full motor speed is reached within a few seconds and the motor maximum drive pressure is limited to approximately 5000 PSI (345 Bar) by the system relief valve. Oil exiting VIBRATOR MOTORS (M3 & M4) returns to the unit. Case drain oil from the motors returns to the reservoir after being filtered by CASE DRAIN RETURN FILTER (F1). Case drain pressure is limited to 50 PSI (3.4 Bar) by the CASE DRAIN RELIEF VALVE (RV3).

Releasing the “VIBRO” button stops the hydraulic oil flow to the VIBRATOR MOTORS (M3 & M4). The vibrator stops vibrating.

B. MANDREL DRIVE

With the diesel engine running and the winch auxiliary valve ready to be used, hydraulic oil from the winch auxiliary valve is to run the mandrel motors.



**MODEL 200
BOTTOM DRIVE
WICK INSERTER**

**OPERATING
INSTRUCTIONS**

V. HYDRAULIC CIRCUITRY

HYDRAULIC SCHEMATIC

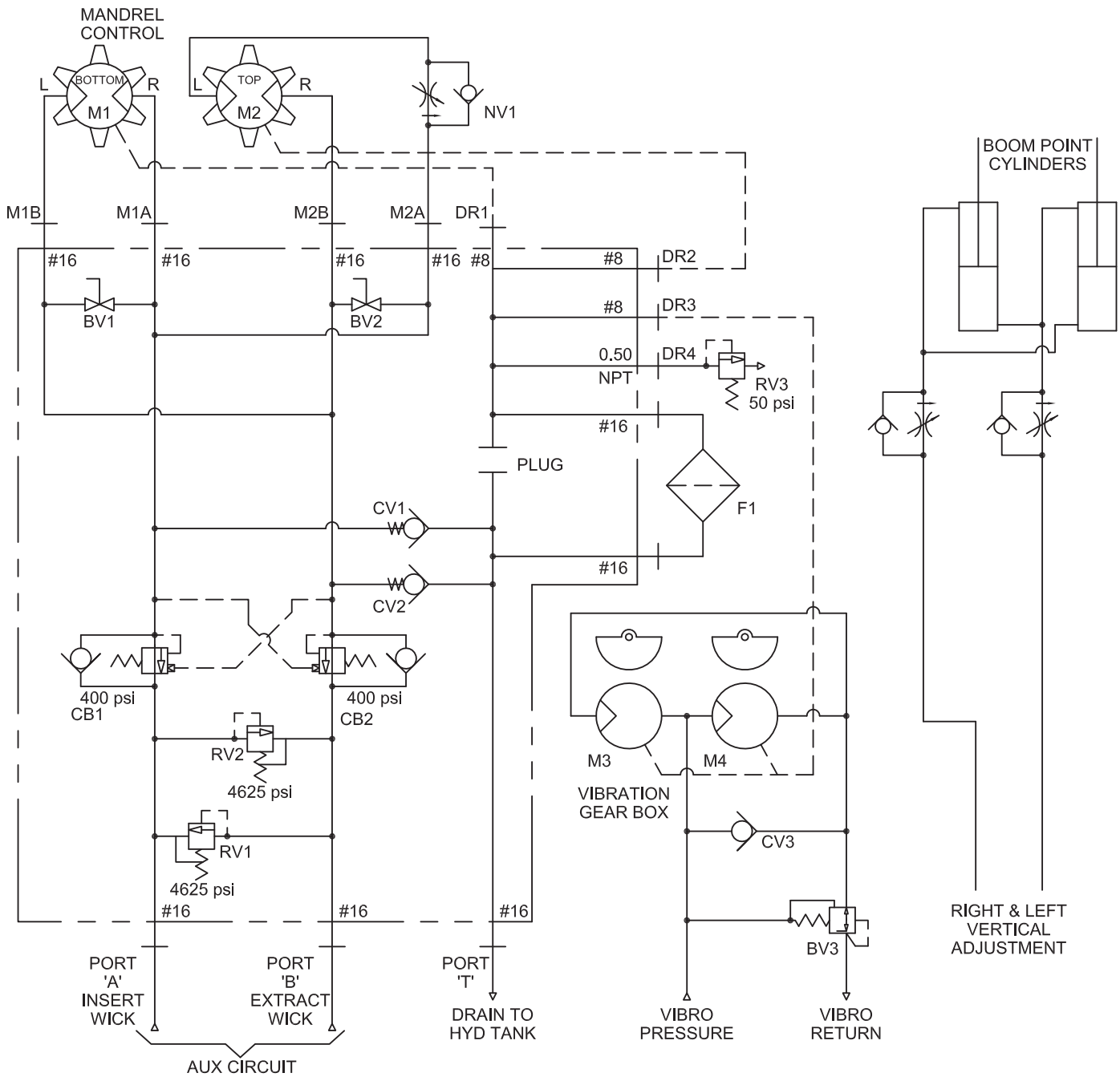



**MODEL 200
BOTTOM DRIVE
WICK INSERTER**

**OPERATING
INSTRUCTIONS**

V. HYDRAULIC CIRCUITRY

B. HYDRAULIC COMPONENTS LIST

<u>Notation</u>	<u>Description</u>	<u>Part Number</u>	<u>Page Number</u>
BV1	Free Wheel Valve		VII-15
BV2	Free Wheel Valve		VII-15
BV3	Brake Valve	1001844	VII-27
CB1	Counterbalance Valve	352117	VII-15
CB2	Counterbalance Valve	352117	VII-15
CV1	Drain Check Valve	1001808	VII-15
CV2	Drain Check Valve	1001808	VII-15
CV3	Gear Box Anti-Cav Check Valve	1001693	VII-29
F1	Case Drain Filter		
NV1	Needle Valve		
M1	Mandrel Drive Motor	352001	VII-7
M2	Mandrel Drive Motor	352001	VII-7
M3	Gear Box Motor	122001A	VII-13
M4	Gear Box Motor	122001A	VII-13
RV1	Relief Valve	1000813	VII-15
RV2	Relief Valve	1000813	VII-15
RV3	Pop Off Relief Valve	321009	VII-15



**MODEL 200
BOTTOM DRIVE
WICK INSERTER**

OPERATING INSTRUCTIONS



**MODEL 200
BOTTOM DRIVE
WICK INSERTER**

PARTS LIST

VII. GENERAL DATA

A. ABBREVIATIONS

The abbreviations shown below are used throughout the parts lists and various other parts of the manual.

ASM.	Assembly
BHCS	Button Head Cap Screw
Cyl.	Cylinder
DC	Direct Current
FHCS	Flat Head Cap Screw
FLCS	Flanged Head Cap Screw
HC	High Collar
HHCS	Hex Head Cap Screw
HHPP	Hex Head Pipe Plug
HSSS	Hex Socket Set Screw
Hyd.	Hydraulic
Lg.	Long
mm	Millimeter
Mtg.	Mounting
NPT.	National Pipe Thread
PHMS	Phillips Head Machine Screw
P/N	Part Number
Qty.	Quantity
RHMS	Round Head Machine Screw
Sch.	Schedule
SHCS	Socket Head Cap Screw
SHPP	Socket Head Pipe Plug
SHSS	Socket Head Shoulder Screw
S/N	Serial Number
Sol.	Solenoid

B. SCREWS AND BOLTS

1. Practically all connections on the unit are made with socket head (Allen) cap screws. These high-strength screws are available at most industrial supply houses.
2. Screws and bolts are designated in the PARTS LIST in abbreviated form. (Refer to subsection A, above, for specific abbreviations.) Listed below is a typical screw description:
0.50 - 13 UNC X 1.50 LG SHCS

0.50 = Diameter

13 UNC = Threads Per Inch

1.50 LG = Length

SHCS = Screw Type Abbreviation



**MODEL 200
BOTTOM DRIVE
WICK INSERTER**

PARTS LIST

VII. GENERAL DATA

C. SERIAL NUMBER LOCATIONS

1. The following units are serial numbered separately:
 - a. Vibrator



**MODEL 200
BOTTOM DRIVE
WICK INSERTER**

PARTS LIST

VIII. ORDERING PARTS

A. PROCEDURE

1. When ordering parts, **be sure to include the model and serial number** of the unit or component. Confirm all telephone orders immediately to avoid duplicating shipment.
2. ORIGINAL EQUIPMENT; Where component serial numbers are given, these apply only to equipment and components originally furnished with the unit. Where equipment has been changed or upgraded these numbers may not be an adequate description.
3. SHIPMENT; State to whom shipment is to be made and method of shipment desired, otherwise our own judgement will be used.
4. SHORTAGES; Claims for shortages or errors should be made immediately upon receipt of parts. No responsibility will be assumed for delay, damage or loss of material while in transit. Broken, damaged or lost material should be refused or a full description made of damage or loss to the carrier agent on the freight or express bill.
5. RETURN OF PARTS; If for any reason you desire to return parts to the factory or to any distributor from whom these parts were obtained, you must first secure permission to return the parts. Shipping instructions will be given along with this permission. A ten percent handling charge must be assessed against the returned shipment unless an error is made by the factory or by the distributor when filling your order.



**MODEL 200
BOTTOM DRIVE
WICK INSERTER**

PARTS LIST

VIII. ORDERING PARTS

B. FITTING DESCRIPTION KEY

<p style="text-align: center; margin-bottom: 0;"> <u>FITT</u> 2 L - 16 M 12 J 00 0 - 00L 0 0 0 1 </p> <p><u>SELECTOR INDEX</u> 2 - INCH FITTING 9 - METRIC FITTING</p> <p><u>CONFIGURATION OR SHAPE OF FITTING</u> S - STRAIGHT FITTING L - 90 Deg. ELBOW V - 45 Deg. ELBOW T - TEE C - CAP P - PLUG U - UNION X - CROSS (FOURTH END FITT'G REQ'D.)</p> <p><u>FIRST END SIZE</u> * IN 1/16THS OF AN INCH (INDEX 2) IN MILLIMETERS (INDEX 9) SEE GENERAL SPECIFICATION SHEET FOR SEQUENCE OF ORDER</p> <p><u>FIRST END FITTING STYLE</u> SEE FITTING STYLE SELECTOR CHART SC-1</p> <p><u>SECOND END SIZE</u> IF APPLICABLE - SEE FIRST END SIZE</p> <p><u>SECOND END FITTING STYLE</u> IF APPLICABLE - SEE FIRST END FITTING STYLE</p> <p><u>THIRD END SIZE</u> IF APPLICABLE - SEE FIRST END SIZE</p> <p><u>THIRD END FITTING STYLE</u> IF APPLICABLE - SEE FIRST END SIZE</p> <p>* EXCEPTIONS 90 = 10" 96 = 6" 92 = 12" 98 = 8" 94 = 14" 99 = NON CODE SIZE</p>	<p><u>MATERIAL</u> 1 - CARBON STEEL 2 - BRASS 4 - STAINLESS STL 5 - AAR MAL IRON 6 - MALLEABLE IRON 8 - FORGED STEEL</p> <p><u>SPECIAL NOTATIONS</u></p> <p><u>PRESSURE RATING</u> 0 - NONE 1 - 125 LB. 3 - SCH 40 4 - SCH 80</p> <p><u>INSTALLATION AID OR STYLE OF HEAD</u> 0 - NOT APPLICABLE H - REGULAR HEX Q - SQUARE HEAD (EXT.) R - SQUARE HEAD (INT.) S - HEX HEAD (INT SOCKET) T - HEX HEAD (EXT.)</p> <p><u>LENGTH CODE</u> (ELBOWS & NIPPLES) ___L - LONG (ELBOW) ___X - EXTRA LONG (ELBOW) ___C - CLOSE (NIPPLE)</p> <p>PIPE NIPPLES (LONG) ONLY IN DEC. INCHES FOR INDEX 2 050 = 5.0 INCHES 105 = 10.5 INCHES</p> <p>IN MILLIMETERS FOR INDEX 9 120 = 12.0 MILLIMETERS 084 = 8.4 MILLIMETERS</p> <p><u>FOURTH END SIZE & FITTING STYLE</u> (CROSSES ONLY) SEE FIRST END FITTING SIZE OR END STYLE</p>
---	---



**MODEL 200
BOTTOM DRIVE
WICK INSERTER**

PARTS LIST

B. FITTING DESCRIPTION KEY (CONTINUED)

FITTING STYLE SELECTOR CHART

SC-1

FOR END FITTING STYLE SELECTION

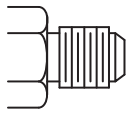
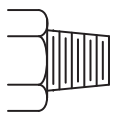
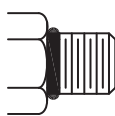
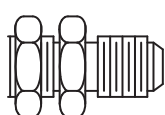
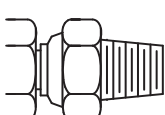
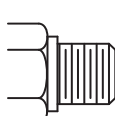
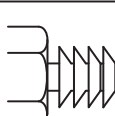
M		JIC MALE 37 Deg. FLARE
P		MALE PIPE NPT
R		S.A.E. MALE O-RING (& ADJUSTABLE)
B		JIC MALE 37 Deg. FLARE BULKHEAD
D		MALE PIPE NPT SWIVEL
S		B.S.P. MALE PIPE
T		HOSE BARB

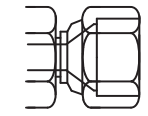
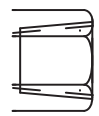
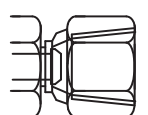
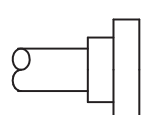
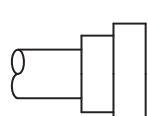
J		JIC FEMALE 37 Deg. FLARE (& SWIVEL)
Q		FEMALE PIPE NPTF
K		S.A.E. FEMALE O-RING
N		FEMALE PIPE NPSM-SWIVEL
F		SPLIT FLANGE 3000 PSI. CODE 61
H		SPLIT FLANGE 6000 PSI. CODE 62



**MODEL 200
BOTTOM DRIVE
WICK INSERTER**

PARTS LIST

VIII. ORDERING PARTS

C. HOSE DESCRIPTION CODE

The HOSE DESCRIPTION CODE is a 24 digit number enabling easier and quicker identification whenever a hose replacement is desired. The key below explains the structure of the coded number in detail.

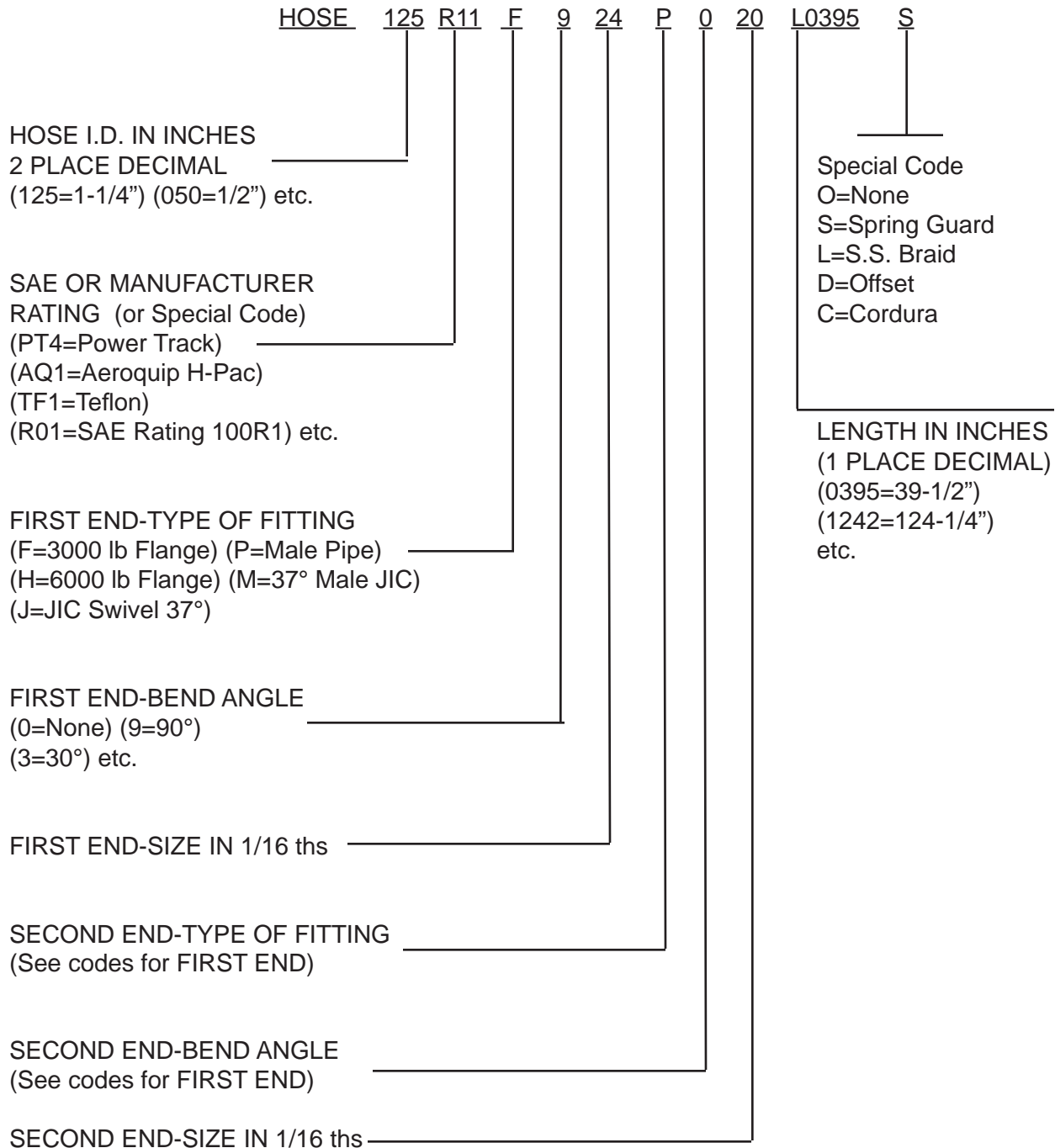



**MODEL 200
BOTTOM DRIVE
WICK INSERTER**

PARTS LIST

VIII. ORDERING PARTS

D. PARTS IDENTIFICATION

1. Parts lists and drawings are included on the following pages for the equipment components shown below:

a. BOTTOM DRIVE INSERTER	1001180
b. GEAR BOX	1001672
c. SUPPRESSOR	1001275
d. MANIFOLD	1001608
e. ROLLER GUIDE	352039
f. DRIVE SPROCKET	352051
g. MANDREL GUIDE	352053
h. WICK CARRIER	1001696
i. WICK GUIDE BRACKET	852085
j. BRAKE MANIFOLD	1001703

2. The spare parts list SECTION VIII - RECOMMENDED SPARE PARTS contains spare parts which may be very useful in keeping down-time to a minimum, especially in remote or secluded job sites where unforeseen communication problems could cause delay of the delivery of an awaited part.

These RECOMMENDED SPARE PARTS may be ordered beforehand, individually or as a package group as shown in the PARTS LIST.



MODEL 200
BOTTOM DRIVE
WICK INSERTER

PARTS LIST

BOTTOM DRIVE INSERTER

1001180

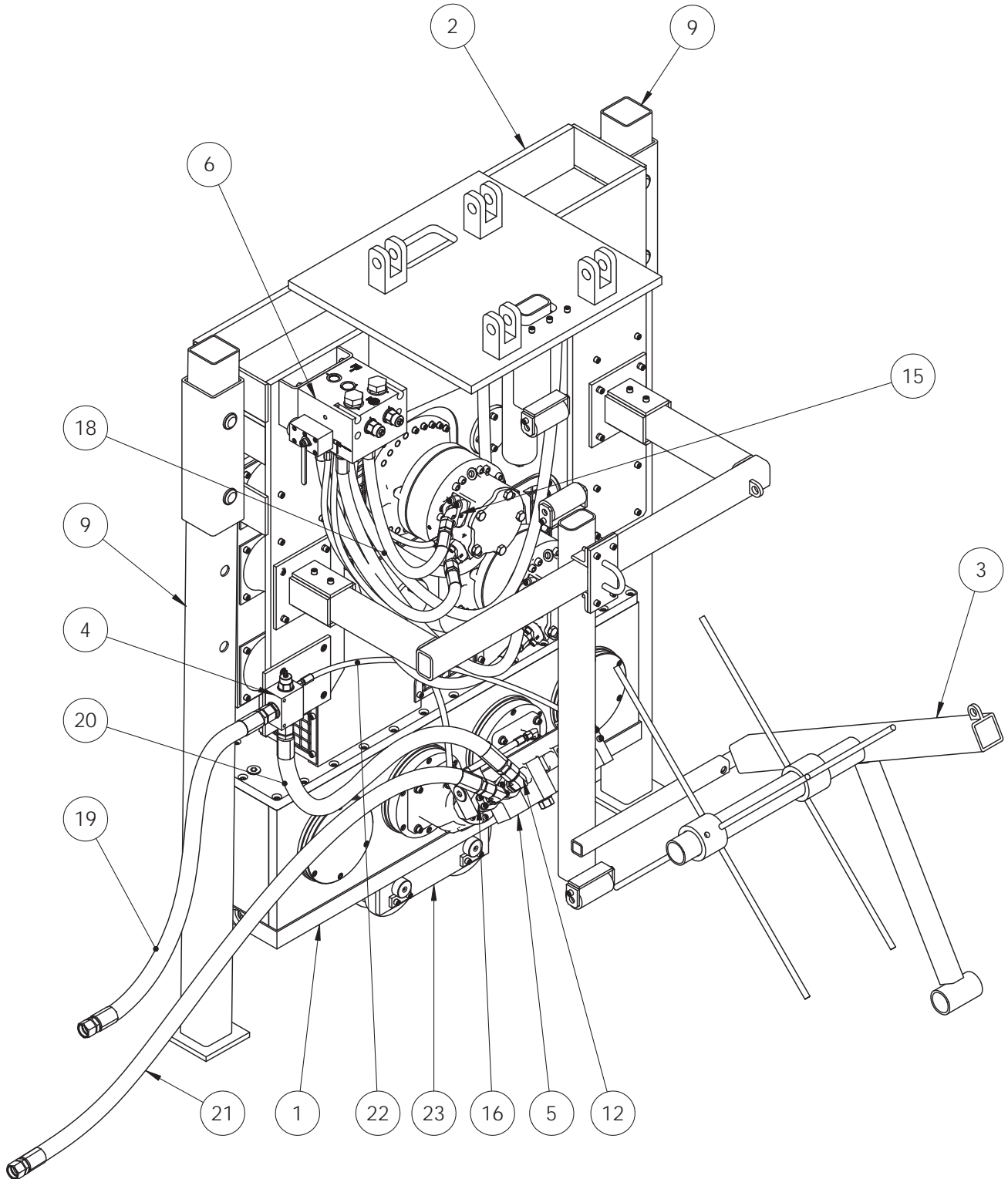



MODEL 200
BOTTOM DRIVE
WICK INSERTER

PARTS LIST

BOTTOM DRIVE INSERTER

1001180

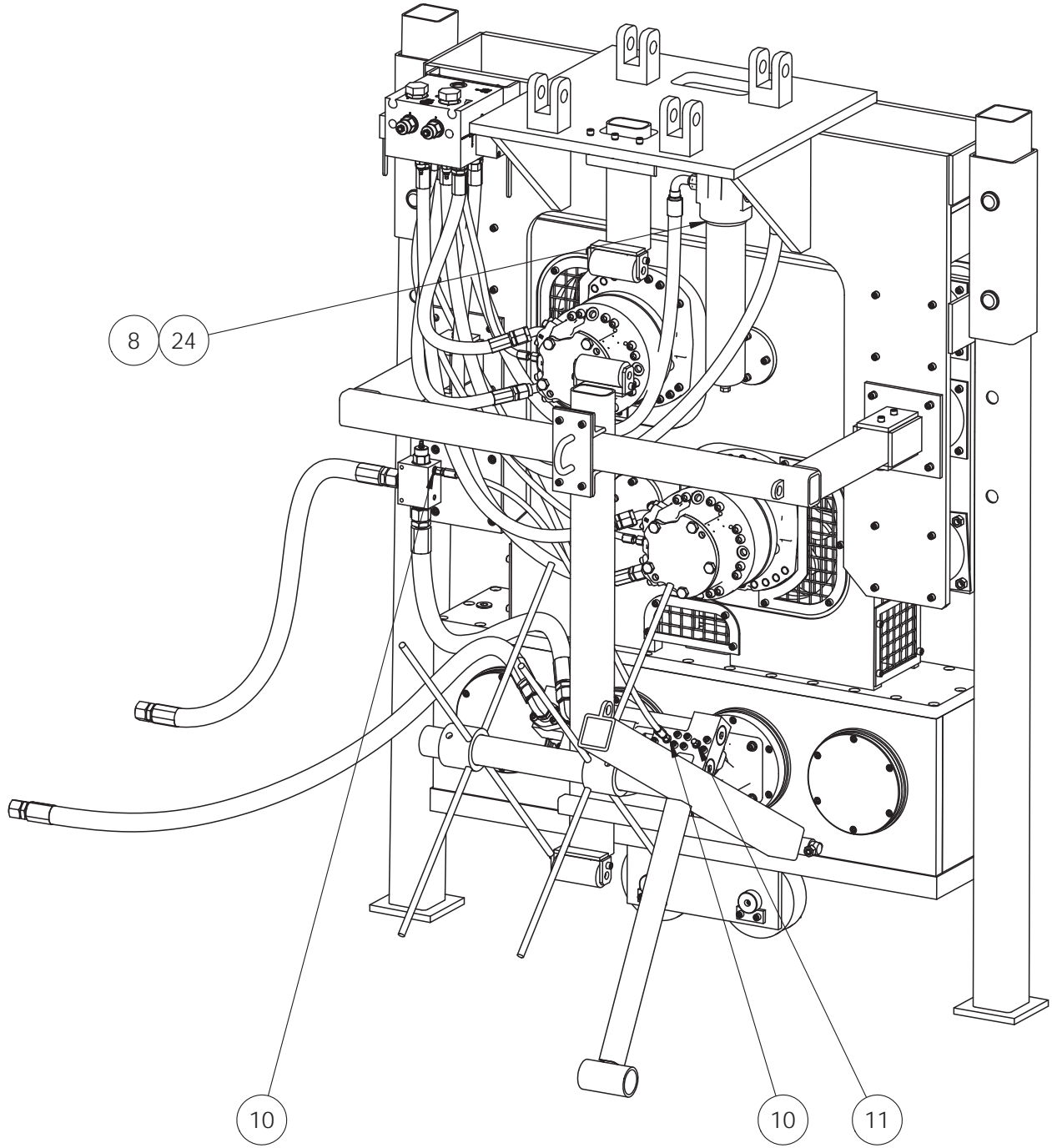



**MODEL 200
BOTTOM DRIVE
WICK INSERTER**

PARTS LIST



**MODEL 200
BOTTOM DRIVE
WICK INSERTER**

PARTS LIST

BOTTOM DRIVE INSERTER

1001180

<u>Item</u>	<u>Part Number</u>	<u>Qty.</u>	<u>Description</u>
1	1001672	1	200 WICK DRAIN-GEAR BOX ASM
2	1001275	1	SUPPRESSOR ASM
3	1001696	1	WICK CARRIER ASM
4	1001703	1	BRAKE VALVE ASM
5	1001277	1	200 WICK MANIFOLD ASM
6	1001608	1	WICK MANIFOLD
7	100037	6	2-222 O-RING 90 DURO
8	1001411	1	RETURN FILTER ASM
9	352129	2	STAND OFF LEG
10		3	FITT2S-05M05R
11		1	FITT2C-05J
12	170465	2	FITTSL-20M20R
13		32	0.50 HI COLLAR L/W
14		32	0.50-13UNCA3 SHCS
15	124233	4	#20 SPLIT FLANGE CODE 62
16		2	#20 SOLID #20 O-RING
17	170457	4	FITT2S-20M20R
18		1	200 WICK DRAIN HOSE BUNDLE
19		1	HOSE
20		1	HOSE
21		1	HOSE
22		1	HOSE
23	352039	1	ROLLER GUIDE ASM
24	100586	1	RETURN FILTER ELEMENT



**MODEL 200
BOTTOM DRIVE
WICK INSERTER**

PARTS LIST

GEAR BOX

1001672

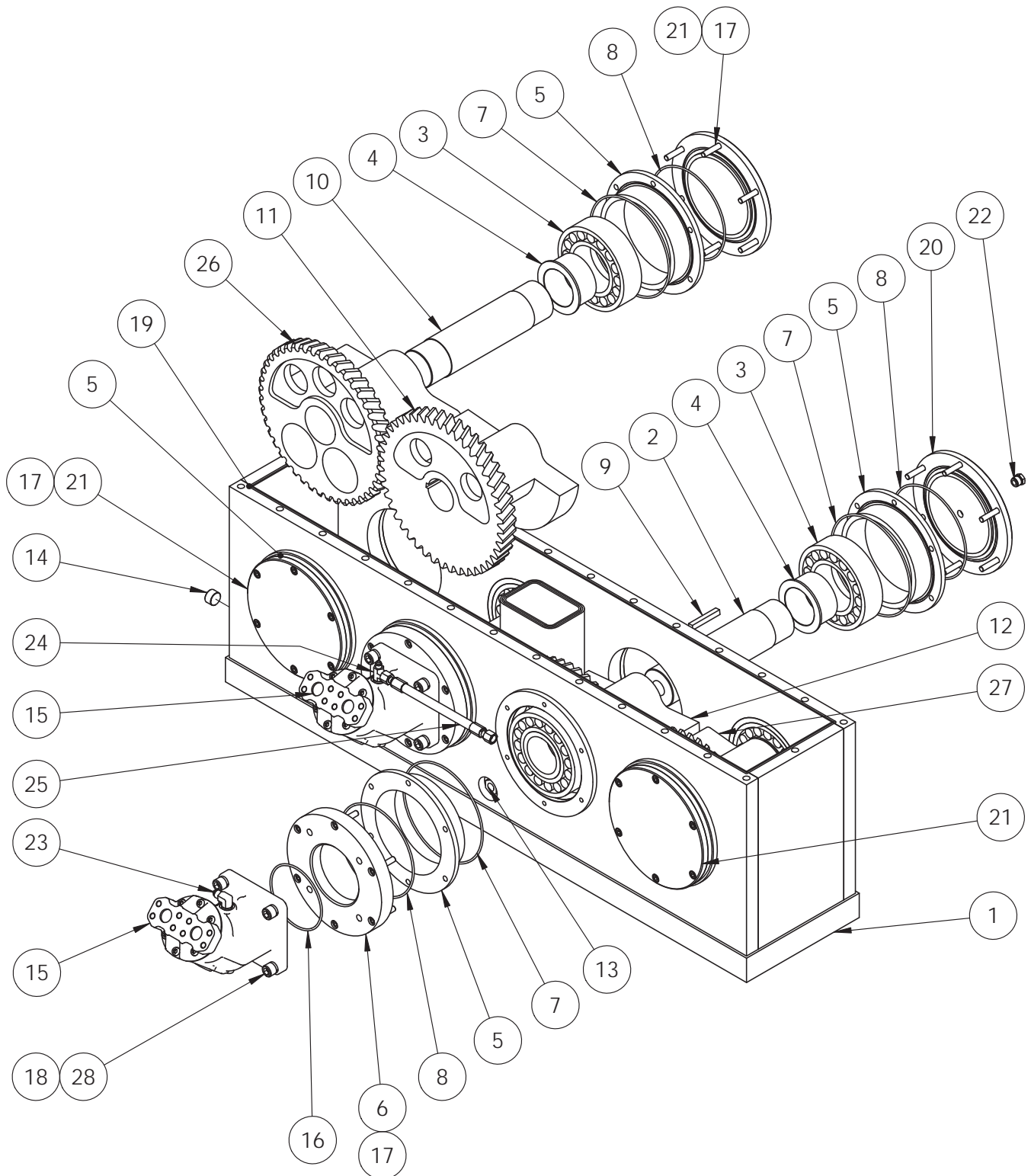



**MODEL 200
BOTTOM DRIVE
WICK INSERTER**

PARTS LIST

GEAR BOX

1001672

<u>Item</u>	<u>Part Number</u>	<u>Qty.</u>	<u>Description</u>
1	1001272	1	200 WICK GEARBOX MACHINE
2	352045	2	DRIVE SHAFT
3	181001A	8	ECCENTRIC BEARING
4	181005	8	BEARING SLEEVE
5	181002	8	BEARING CARRIER
6	352011	2	BEARING COVER MOTOR MOUNT
7	352067	8	2-274 O-RING
8	352081	8	2-272 O-RING
9	352065	2	KEY
10	181003	2	ECCENTRIC SHAFT
11	1001692	1	WICK ECC DRIVE LEFT
12	1001691	1	WICK ECC DRIVE RIGHT
13	123005	1	SIGHT GLASS
14	123004	1	1 INCH NPT MAG PLUG
15	122001A	2	VIBRO MOTOR FM125
16	352113	2	2-163 O-RING
17		48	0.50-13 SHCS
18	400727	8	0.75 HI-COLLAR L/W
19	352079	176	O-RING CORD 0.13 C.S.
20	352077	2	BEARING COVER WITH BREATHER PORT
21	181004	4	BEARING COVER
22	122015	2	GEAR BOX BREATHER
23	100933	1	FITT2L08M10R
24		1	FITT2T-10R008R08R
25		1	HOSE050R02J008J008L01500
26	1001685	1	ECCENTRIC RIGHT HOLLOW
27	1001686	1	ECCENTRIC LEFT-HOLLOW
28	400069	8	0.75-10UINC X 2.00 LG SHCS



MODEL 200
BOTTOM DRIVE
WICK INSERTER

PARTS LIST

SUPPRESSOR

1001275

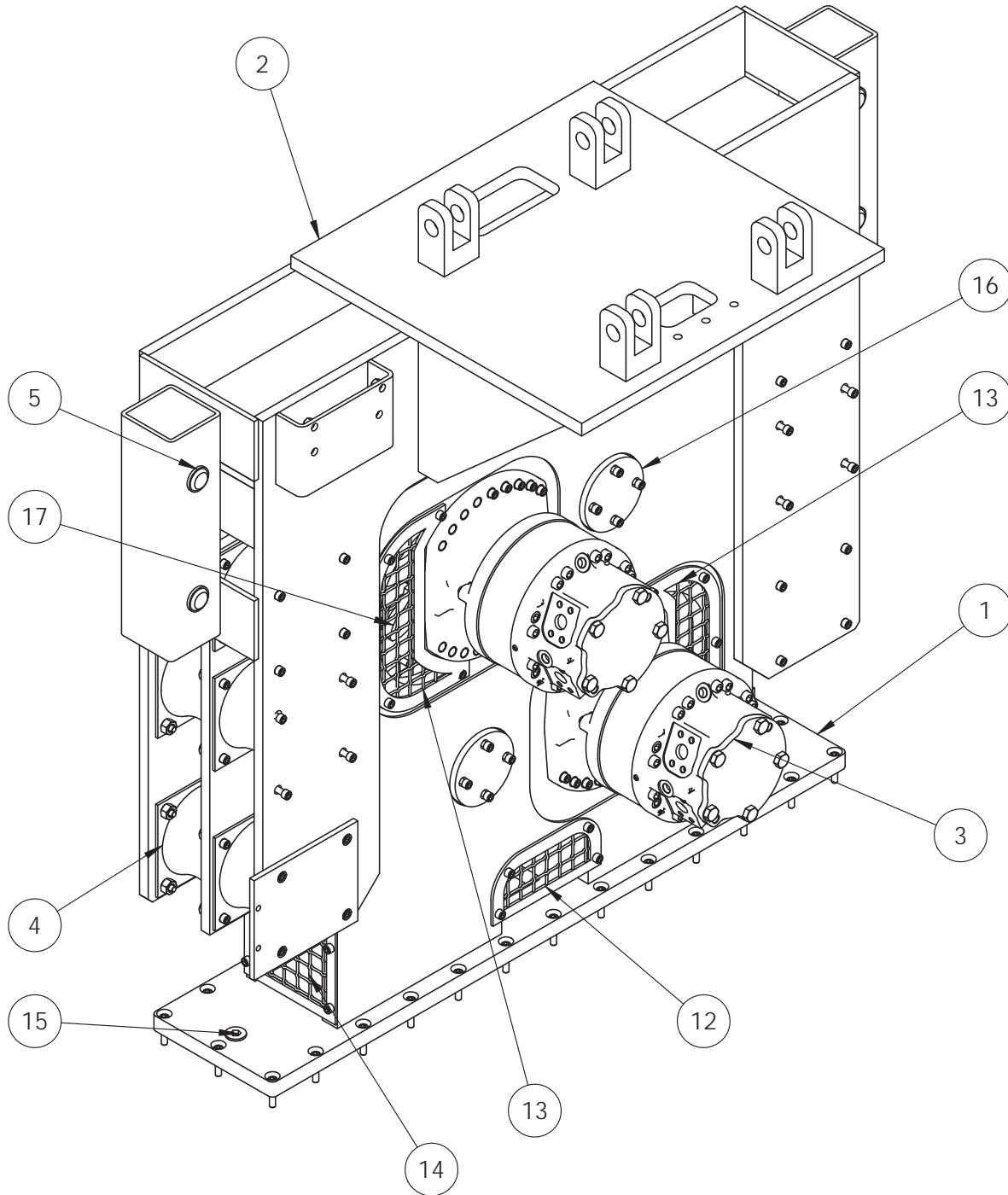



**MODEL 200
BOTTOM DRIVE
WICK INSERTER**

PARTS LIST

SUPPRESSOR

1001275

<u>Item</u>	<u>Part Number</u>	<u>Qty.</u>	<u>Description</u>
1	1001274	1	INNER SUPPRESSOR HOUSING
2	1001694	1	OUTER SUPPRESSOR HOUSING
3	352027	2	MANDREL MOTOR
4	321004A	12	ELASTOMER BLUE
5	352131	4	LEG PIN
6		4	COTTER PIN
7		171	
8		24	
9		63	
10		1	LOWER SPROCKET COVER
11		1	UPPER SPROCKET COVER
12		1	LOWER COVER
13		2	MOTOR COVER
14		2	SIDE COVER
15		1	FITT2P-16P
16	352053	2	MANDREL GUIDE ASM
17	352051	2	DRIVE SPROCKET ASM



MODEL 200
BOTTOM DRIVE
WICK INSERTER

PARTS LIST

MANIFOLD

1001608

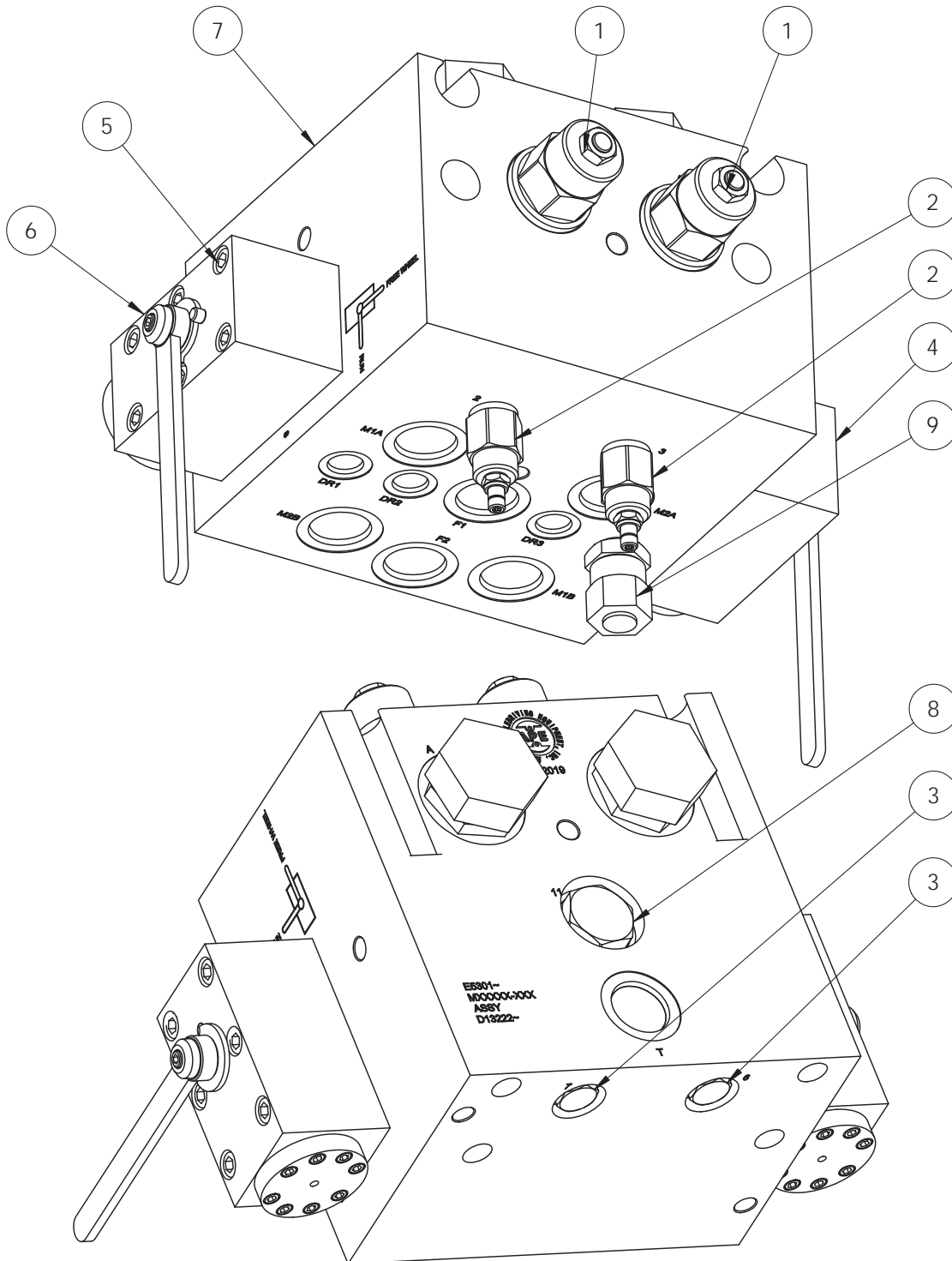



**MODEL 200
BOTTOM DRIVE
WICK INSERTER**

PARTS LIST

MANIFOLD

1001608

<u>Item</u>	<u>Part Number</u>	<u>Qty.</u>	<u>Description</u>
1	352117	2	COUNTER BALANCE VALVE
2	1000813	2	RELIEF VALVE
3	1001808	2	CHECK VALVE
4	1001635	1	FREE WHEEL VALVE RIGHT HAND
5	110913	12	0.38-16UNC X 3.00 LG SHCS
6	1001634	1	FREE WHEEL VALVE LEFT HAND
7	1001636	1	MANIFOLD BLOCK
8	1001826	1	CAVITY PLUG
9	321009	1	POP OFF VALVE



MODEL 200
BOTTOM DRIVE
WICK INSERTER

PARTS LIST

ROLLER GUIDE

352039

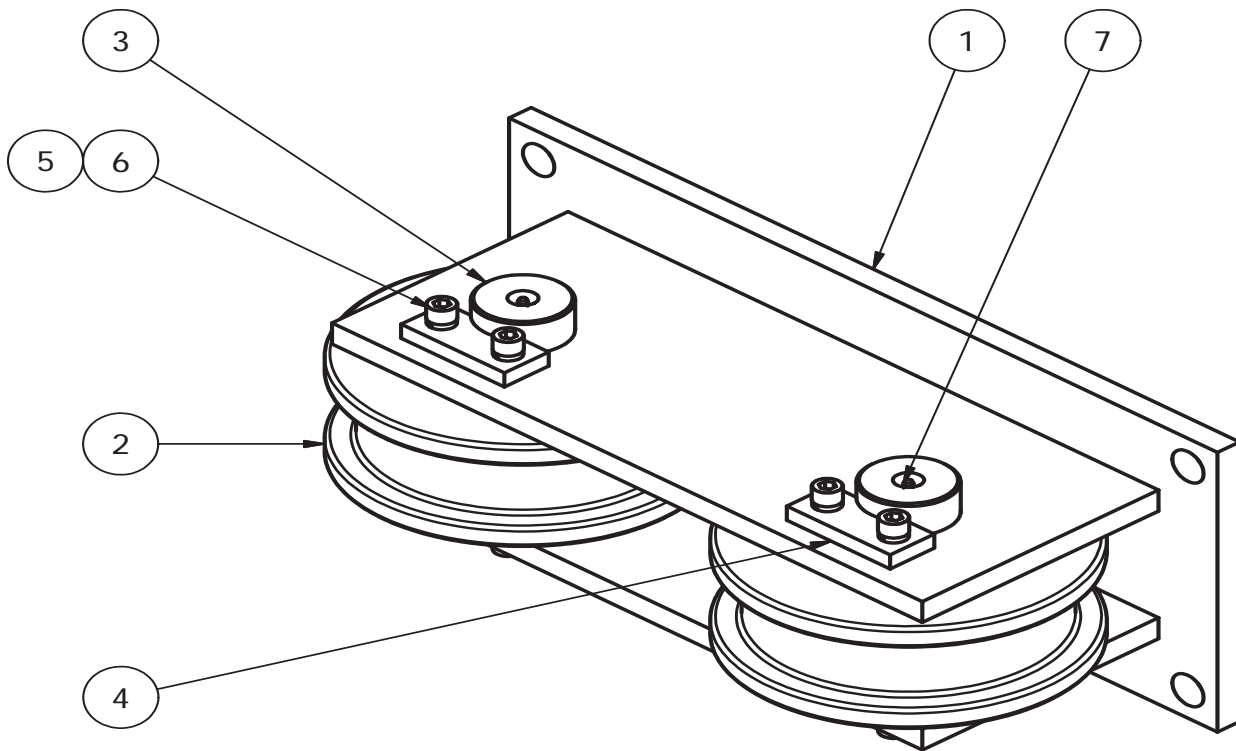



**MODEL 200
BOTTOM DRIVE
WICK INSERTER**

PARTS LIST

ROLLER GUIDE

352039

<u>Item</u>	<u>Part Number</u>	<u>Qty.</u>	<u>Description</u>
1	352132	1	GUIDE ROLLER FRAME
2	352025	2	GUIDE ROLLER w/ BUSHING
3	352026	2	GUIDE ROLLER PIN
4	352028	4	KEEP PLATE
5	*	8	0.50 HI COLLAR LOCK WASHER
6	*	8	0.50-13UNC X 1.25 SHCS
7	FITT	4	GREASE FITTING 0.13 NPT
* FITT	352123 352125		INCLUDED IN FASTENER KIT INCLUDED IN FITTING KIT



**MODEL 200
BOTTOM DRIVE
WICK INSERTER**

PARTS LIST

SPROCKET AND HUB ASSEMBLY

1002143

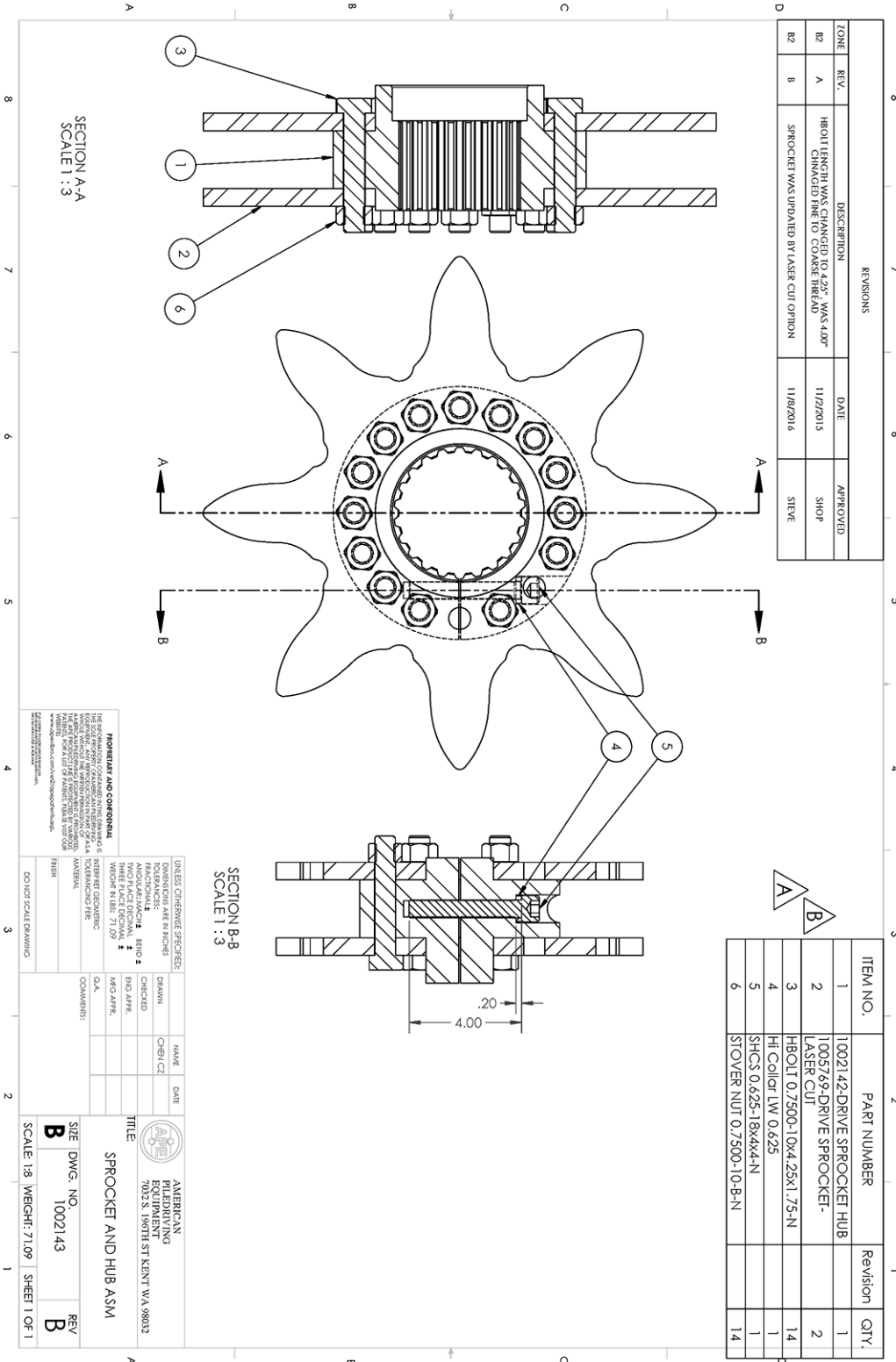

REVISIONS			
ZONE	REV.	DESCRIPTION	DATE
R2	A	HBOLT LENGTH WAS CHANGED TO 4.25" WAS 4.00"	11/2/2015
R2	B	SPROCKET WAS UPDATED BY LASER CUT OPTION	11/8/2016

APPROVED	SHOP
STEVE	

ITEM NO.	PART NUMBER	Revision	QTY.
1	1002142-DRIVE SPROCKET HUB	1	1
2	1005769-DRIVE SPROCKET-LASER CUT	2	2
3	HBOLT 0.7500-1.0X4.25X1.75-N	14	14
4	HI COLLAR LW 0.625	1	1
5	SHCS 0.625-18X4X4-N	1	1
6	STOVER NUT 0.7500-10-B-N	14	14

PROPRIETARY AND CONFIDENTIAL

THIS DRAWING IS THE PROPERTY OF AMERICAN PILEDIVING EQUIPMENT INC. IT IS TO BE USED FOR THE MANUFACTURE OF THE PARTS IDENTIFIED HEREIN. IT IS NOT TO BE REPRODUCED, COPIED, OR TRANSMITTED IN ANY FORM OR BY ANY MEANS, ELECTRONIC OR MECHANICAL, INCLUDING PHOTOCOPYING, RECORDING, OR BY ANY INFORMATION STORAGE AND RETRIEVAL SYSTEM. ANY UNAUTHORIZED USE OF THIS DRAWING IS PROHIBITED AND WILL BE PROSECUTED TO THE FULL EXTENT OF THE LAW.

UNLESS OTHERWISE SPECIFIED:
DIMENSIONS ARE IN INCHES
FRACTIONS ARE IN 16THS
TWO PLACE DECIMAL
THREE PLACE DECIMAL
WHEEL RADIUS 71.09"

FINISH: UNLESS OTHERWISE SPECIFIED, ALL SURFACES SHALL BE FINISHED TO A 32 RAY SURFACE FINISH.

DATE: 11/2/2015

SCALE: 1:3

WEIGHT: 71.09

SHEET 1 OF 1

A 8 7 6 5 4 3 2 1



**MODEL 200
BOTTOM DRIVE
WICK INSERTER**

PARTS LIST

SPROCKET AND HUB ASSEMBLY

1002143

<u>Item</u>	<u>Part Number</u>	<u>Qty</u>	<u>Description</u>
1	1002142	1	Drive Sprocket Hub Drive
2	1005769	2	Sprocket-Laser Cut Bolt
	1005169		Kit
3	Includes:	14	HBolt 3/4-10x4-1/4x1-3/4-N
4		1	HCLW 0.625
5		1	SHCS 0.625-18x4x4-N
6		14	Stover Nut 3/4-10-B-N

SPROCKET AND HUB ASSEMBLY - OLD STYLE

352021

<u>Item</u>	<u>Part Number</u>	<u>Qty.</u>	<u>Description</u>
1	352000	2	DRIVE SPROCKET
2	352003	1	DRIVE HUB
3	*	8	0.63-11UNC X 4.00 HHCS
4	*	8	0.63-11UNC STOVER NUT
5	*	1	0.63-18UNF X 3.00 LG SHCS
*	352123		INCLUDED IN FASTENER KIT



MODEL 200
BOTTOM DRIVE
WICK INSERTER

PARTS LIST

MANDREL GUIDE

352053

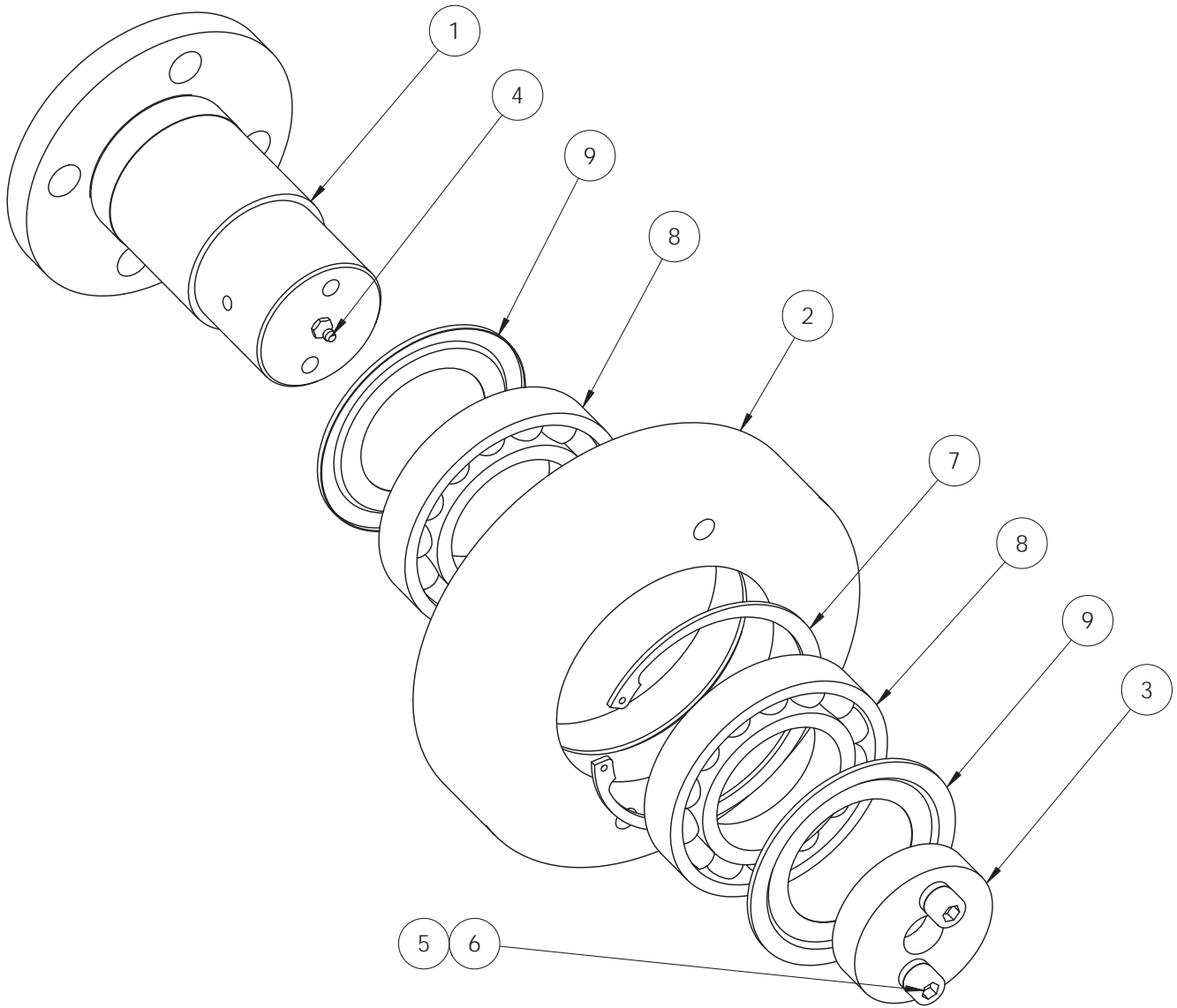



**MODEL 200
BOTTOM DRIVE
WICK INSERTER**

PARTS LIST

MANDREL GUIDE

352053

<u>Item</u>	<u>Part Number</u>	<u>Qty.</u>	<u>Description</u>
1	352014	1	MANDREL GUIDE SUPPORT PIN
2	352004A	1	MANDREL GUIDE ROLLER
3	352007	1	END PLATE
4		1	GREASE FITTING
5	100027	2	0.50 HI-COLLAR L/W
6	100513	2	0.50-13UNC X 1.50 LG SHCS
7	352016	1	RETAINER RING
8	352015	2	BALL BEARING *
9	352015A	2	NILOS RING

* Must remove the seal facing the retainer ring.



**MODEL 200
BOTTOM DRIVE
WICK INSERTER**

PARTS LIST

WICK CARRIER

1001696

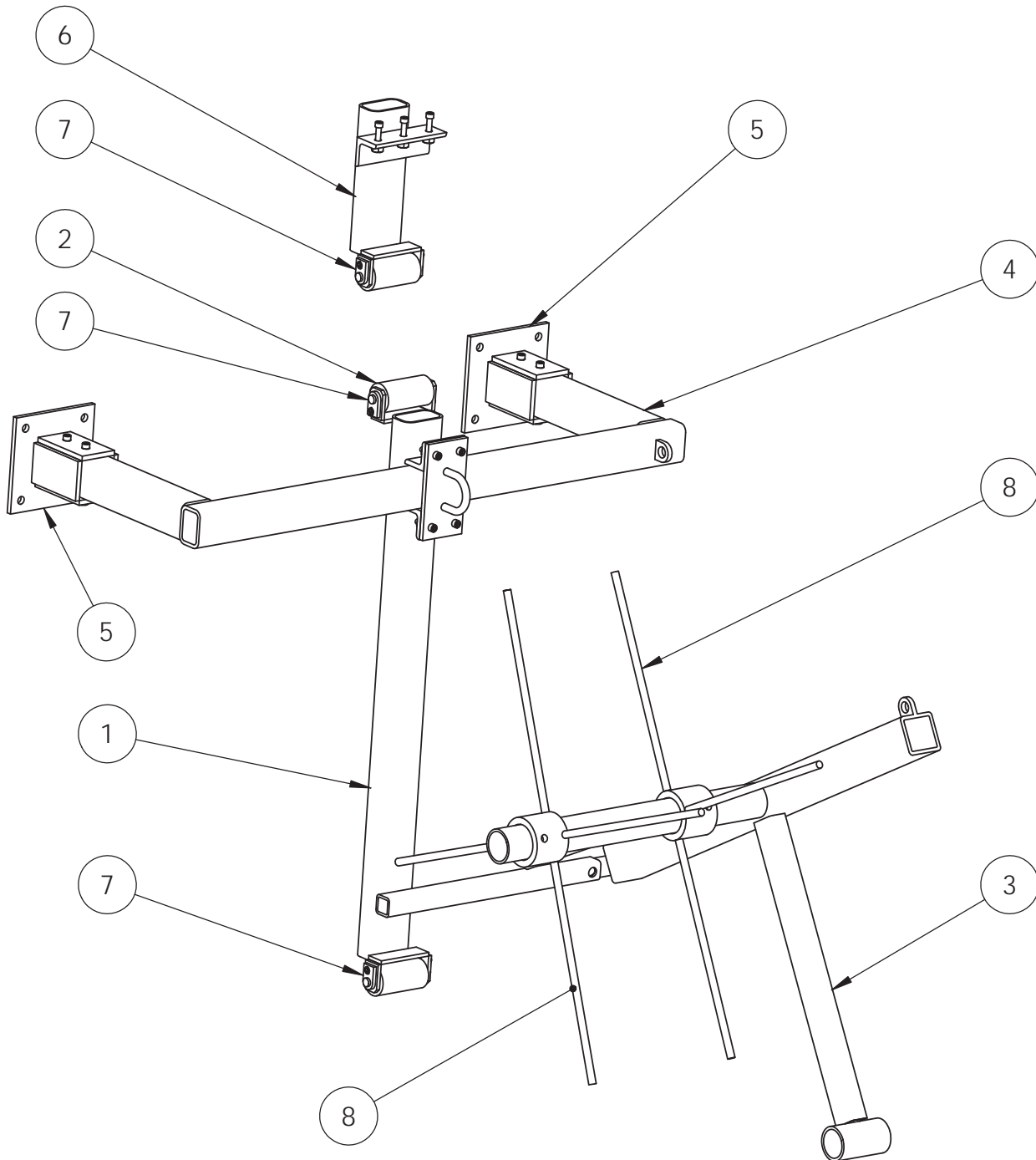



**MODEL 200
BOTTOM DRIVE
WICK INSERTER**

PARTS LIST

WICK CARRIER

1001696

<u>Item</u>	<u>Part Number</u>	<u>Qty.</u>	<u>Description</u>
1	352137	1	6 ROLL MOUNT FRAME
2	352063	3	WICK SUPPORT ROLLER
3	352134	1	6 ROLL WICK CARRIER
4	1001502	1	SUPPORT FRAME
5	352061	2	SUPPORT FRAME BRACKET
6	352095	1	MOUNT FRAME TOP
7	352097	3	ROLLER PIN
8	352136	2	6 ROLL WICK BAR ASM



MODEL 200
BOTTOM DRIVE
WICK INSERTER

PARTS LIST

WICK GUIDE BRACKET

352085

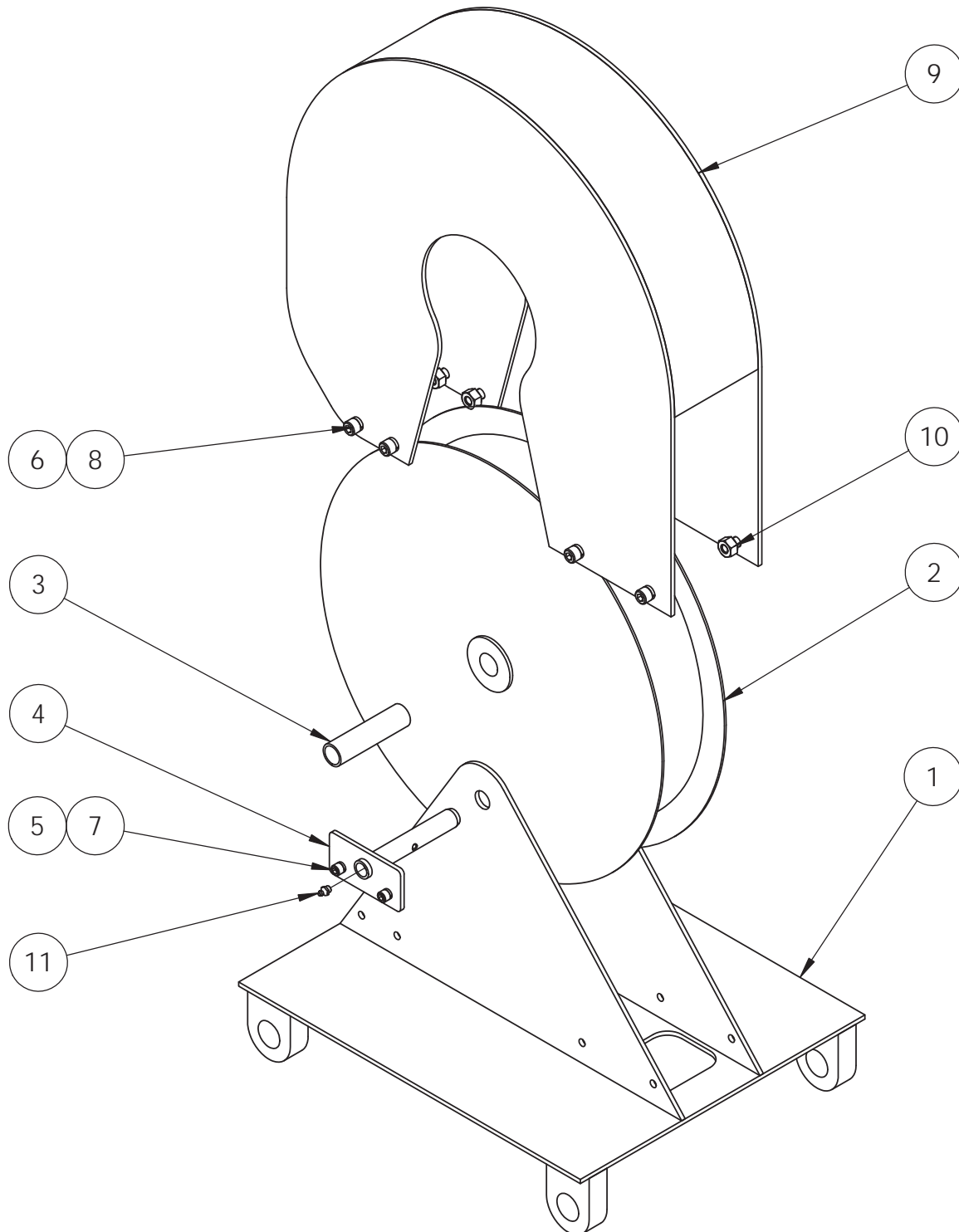



**MODEL 200
BOTTOM DRIVE
WICK INSERTER**

PARTS LIST

WICK GUIDE BRACKET

352085

<u>Item</u>	<u>Part Number</u>	<u>Qty.</u>	<u>Description</u>
1	352087	1	WICK GUIDE ROLLER BRACKET
2	352089	1	WICK GUIDE ROLLER
3	352091	1	BUSHING
4	352111	1	WICK GUIDE PIN
5		2	0.38 HI COLLAR LOCK WASHER
6		8	0.50 HI-COLLAR L/W
7		2	0.38-16UNC X 0.75 LG SHCS
8		8	0.50-13UNC X 1.25 LG SHCS
9	1001101	1	ROLLER BRACKET COVER
10		8	0.50-13UNC HEX NUT
11		1	GREASE FITTING



**MODEL 200
BOTTOM DRIVE
WICK INSERTER**

PARTS LIST

BRAKE VALVE MANIFOLD

1001703

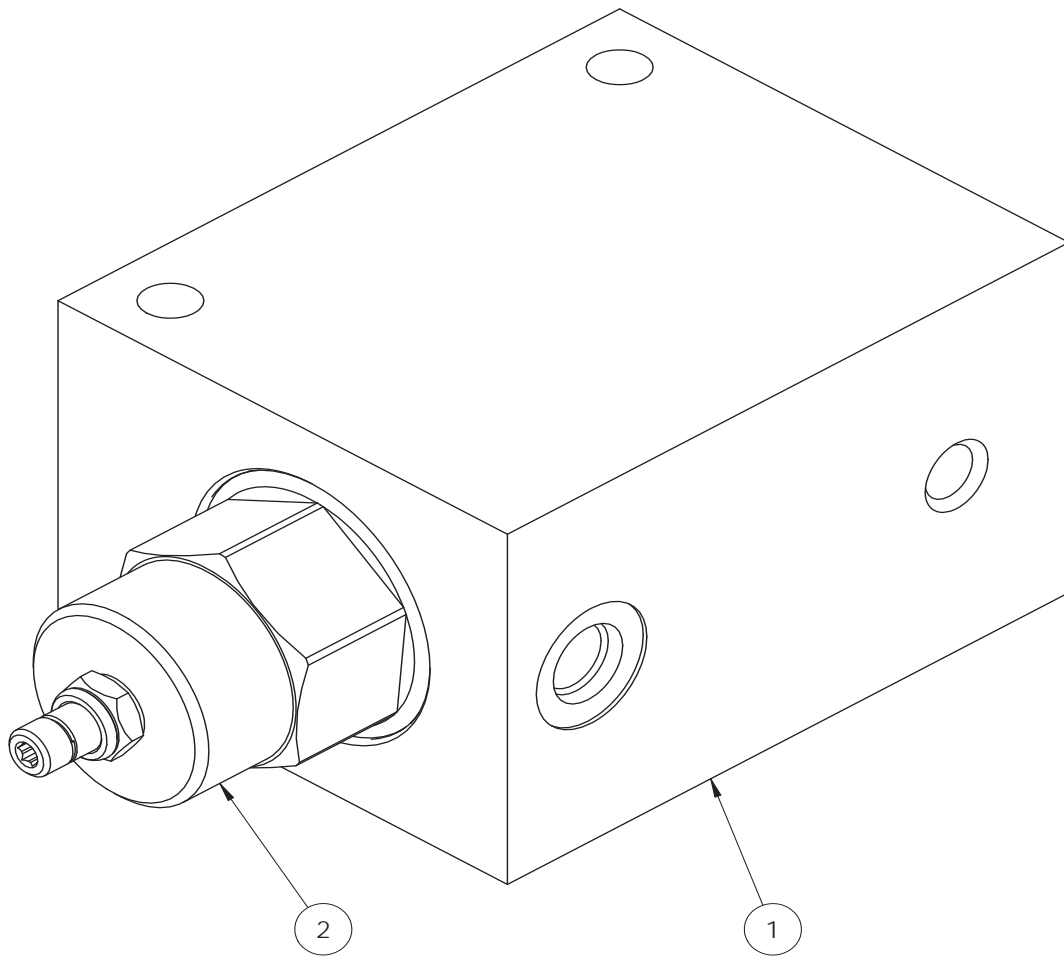



**MODEL 200
BOTTOM DRIVE
WICK INSERTER**

PARTS LIST

BRAKE VALVE MANIFOLD

1001703

<u>Item</u>	<u>Part Number</u>	<u>Qty.</u>	<u>Description</u>
1	1001843	1	VALVE BODY
2	1001844	1	PRESSURE REDUCING VALVE



**MODEL 200
BOTTOM DRIVE
WICK INSERTER**

PARTS LIST

200 WICK MANIFOLD

1001277

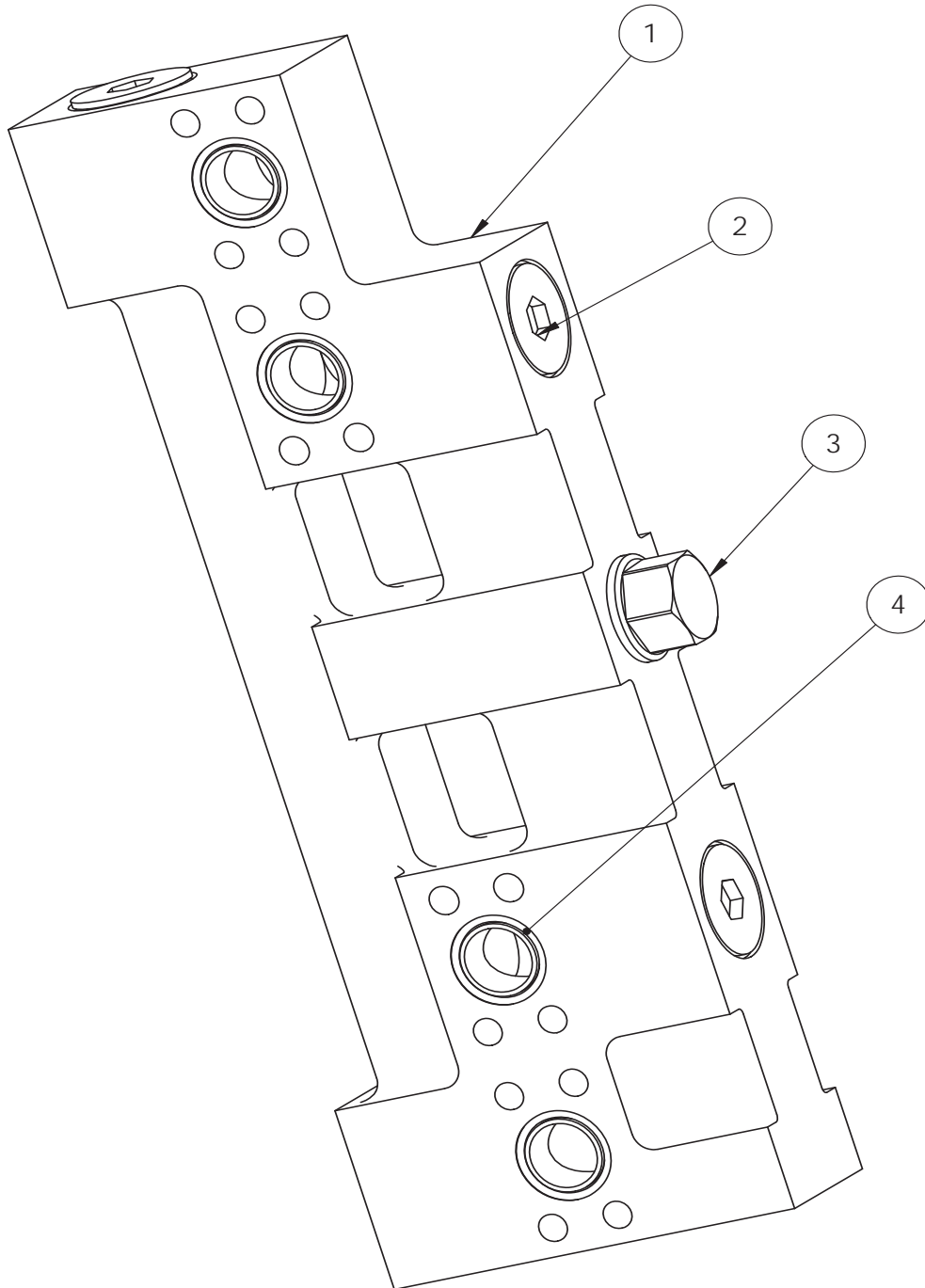



**MODEL 200
BOTTOM DRIVE
WICK INSERTER**

PARTS LIST

200 WICK MANIFOLD

1001277

<u>Item</u>	<u>Part Number</u>	<u>Qty.</u>	<u>Description</u>
1	1001276	1	200 WICK DRAIN MANIFOLD
2	160503	7	FITT2P-20R
3	1001693	1	CHECK VALVE
4	100037	4	2-222 O-RING



**MODEL 200
BOTTOM DRIVE
WICK INSERTER**

PARTS LIST

VIII. ORDERING PARTS

E. MISCELLANEOUS ACCESSORIES

1. Bulk

Part Number	Qty.	Description
810011	5 GAL	Vibration Case Lubricant
100298	1 GAL	APE / J&M Yellow Paint
100299	1 GAL	Primer

2. 200 Wick Hose Kit

P/N	Qty.	Description
	2	HOSE125R13J020J020L09600
	1	HOSE050R02J008J008L07900

3. 200 Wick O-Ring Kit

P/N	Qty.	Description
100037	8	2-222 O-RING
352067	8	2-274 O-RING
352079	176	O-RING CORD 0.13 C.S. / INCH
352081	8	2-272 O-RING
352113	2	2-163 O-RING



**MODEL 200
BOTTOM DRIVE
WICK INSERTER**

PARTS LIST

VIII. ORDERING PARTS

F. RECOMMENDED SPARE PARTS

GEAR BOX 1001672 Refer to page VIII-10

<u>P/N</u>	<u>Qty.</u>	<u>Description</u>
123005	1	Sight Gage
352067	8	2-274 O-Ring
352081	8	2-272 O-Ring
352113	2	2-163 O-Ring
110142	1	Motor Shaft Seal
122001A	1	Hydraulic Motor
122015	1	Breather

SUPPRESSOR 1001275 Refer to page VIII-12

<u>P/N</u>	<u>Qty.</u>	<u>Description</u>
321004A	1	Elastomer

MANIFOLD 1001608 Refer to page VIII-14

<u>P/N</u>	<u>Qty.</u>	<u>Description</u>
321009	1	Pop Off Relief Valve
1001808	1	Check Valve
1000813	1	Relief Valve
352117	1	Counter Balance Valve

WICK CARRIER 352055 Refer to page VIII-22

<u>P/N</u>	<u>Qty.</u>	<u>Description</u>
352063	3	WICK SUPPORT ROLLER
352097	1	ROLLER PIN



**MODEL 200
BOTTOM DRIVE
WICK INSERTER**

PARTS LIST

G. RECOMMENDED TIGHTENING TORQUE

Nominal Screw Size	Nominal Socket Size	Tightening Torque Ft-Lbs. (Kg-M)	Nominal Screw Size	Nominal Socket Size	Tightening Torque Ft-Lbs. (Kg-M)
#10-24	5/32	6 Ft-Lbs. (.83 Kg-M)	#10-32	5/32	6 Ft-Lbs. (.83 Kg-M)
1/4-20	3/16	13 Ft-Lbs. (1.8 Kg-M)	1/4-28	3/16	15 Ft-Lbs. (2.1 Kg-M)
5/16-18	1/4	27 Ft-Lbs. (3.7 Kg-M)	5/16-24	1/4	30 Ft-Lbs. (4.2 Kg-M)
3/8-16	5/16	48 Ft-Lbs. (6.6 Kg-M)	3/8-24	5/16	55 Ft-Lbs. (7.6 Kg-M)
7/16-14	3/8	77 Ft-Lbs. (10.6 Kg-M)	7/16-20	3/8	86 Ft-Lbs. (11.9 Kg-M)
1/2-13	3/8	119 Ft-Lbs. (16.4 Kg-M)	1/2-20	3/8	133 Ft-Lbs. (18.4 Kg-M)
5/8-11	1/2	234 Ft-Lbs. (32.3 Kg-M)	5/8-18	1/2	267 Ft-Lbs. (36.9 Kg-M)
3/4-10	5/8	417 Ft-Lbs. (57.6 Kg-M)	3/4-16	5/8	467 Ft-Lbs. (64.5 Kg-M)
7/8-9	3/4	676 Ft-Lbs. (93.4 Kg-M)	7/8-14	3/4	742 Ft-Lbs. (102.5 Kg-M)
1-8	3/4	1,009 Ft-Lbs. (139.4 Kg-M)	1-12	3/4	1,126 Ft-Lbs. (155.6 Kg-M)
1-1/4-7	7/8	1,600 Ft-Lbs. (221.1 Kg-M)	1-1/4-12	7/8	1,800 Ft-Lbs. (248.8 Kg-M)
1-1/2-6	1	2,800 Ft-Lbs. (387 Kg-M)	1-1/2-12	1	3,000 Ft-Lbs. (414.6 Kg-M)

NOTE: These values are for Socket head cap screws only. Button heads, Flat heads and Set screws have different values. Check the Allen Hand Book for correct torque specifications.

ITEM NO.	PARTNO	DESCRIPTION	QTY.
1	1001670	20FT MANDREL ASM	2

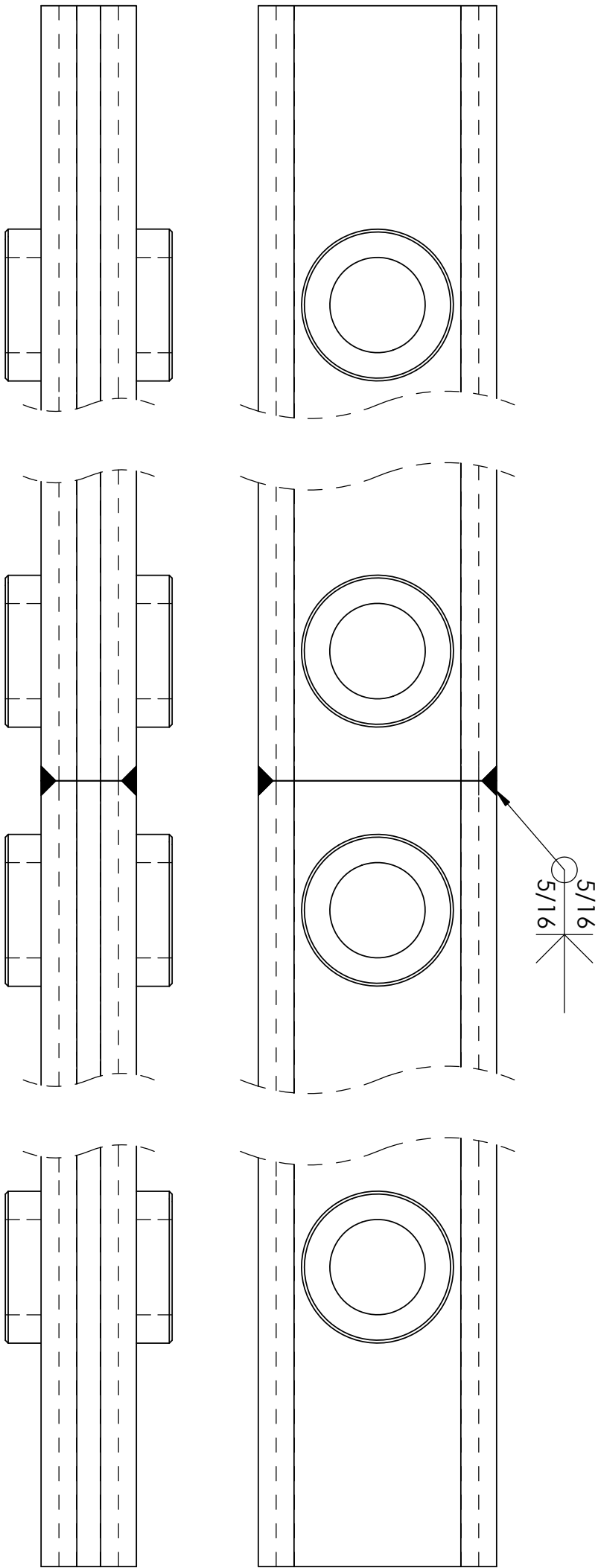
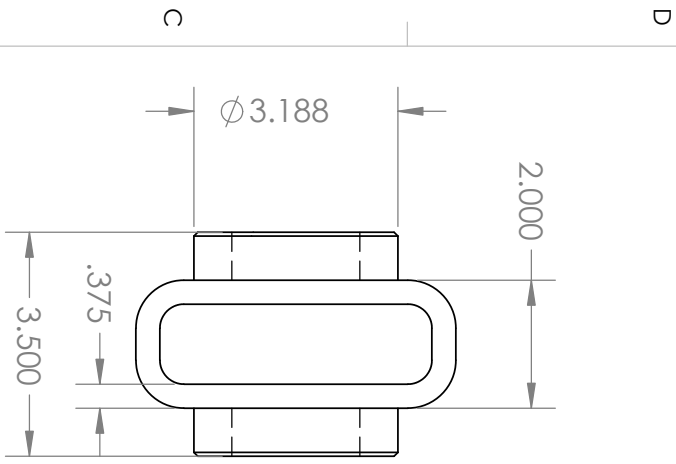

- NOTE: 1,) MANDREL SPICING ENDS HAVE TO BE CHAMFERED BY 5/16 ALL AROUND;
 2,) USING SPICING TEMPLATE (DWG# 0204-050) TO MATCH TWO SPICING MANDRELS;
 3,) USING ER70S-6 WELDING WIRE (OR EQUIVALENT) TO WELD;
 4,) DEBURR AND GRIND OFF ALL EXCESSIVE WELD AND SMOOTH ALL SURFACES.

PROPRIETARY AND CONFIDENTIAL

THE INFORMATION CONTAINED IN THIS DRAWING IS THE SOLE PROPERTY OF AMERICAN PILEDRIVING EQUIPMENT. ANY REPRODUCTION IN PART OR AS A WHOLE WITHOUT THE WRITTEN PERMISSION OF AMERICAN PILEDRIVING EQUIPMENT IS PROHIBITED. THE APE PRODUCT LINE IS PROTECTED BY VARIOUS PATENTS. FOR A LIST OF PATENTS, PLEASE VISIT OUR WEBSITE: www.apeltd.com/ver2/opepatents.asp

UNLESS OTHERWISE SPECIFIED: DIMENSIONS ARE IN INCHES TOLERANCES: FRACTIONAL ±1/32 ANGULAR ±.25° .X: ±0.02" .OX: ±0.01" .00X: ±0.005" WEIGHT IN LBS: 764.93	THIRD ANGLE PROJECTION	NAME CHEN CZ	DATE 10/3/2018	 AMERICAN PILEDRIVING EQUIPMENT 7032 S. 196TH ST KENT WA 98032
MATERIAL: FINISH: DO NOT SCALE DRAWING	INTERPRET GEOMETRIC TOLERANCING PER: MFG APPR. ENG APPR. G.A.	COMMENTS:	TITLE: WICK DRAIN MANDREL SPICE SPEC	
SIZE B	DWG. NO. 1008782	REV	SCALE: 1:96 WT: 764.93	SHEET 1 OF 1