

OPERATING AND MAINTENANCE MANUAL

J&M MODEL J11

VIBRATORY PILE DRIVER/EXTRACTOR

WITH MODEL 230 POWER PACK

**J & M FOUNDATION
EQUIPMENT, LLC.**

CORPORATE OFFICES: 7032 South 196th Street
Kent, WA 98032

OM-J11/230-1006

PREFACE

This manual was prepared to acquaint the owner, operator and serviceman with the operation and maintenance of the vibratory driver/extractor. We suggest that this manual be carefully studied before operating or undertaking any maintenance work on the unit.

This manual is organized into two major categories.

The first category is for routine OPERATING INSTRUCTIONS of the unit and includes a GENERAL DESCRIPTION section, which presents a basic explanation of the driver/extractor and some of its specifications. The MAINTENANCE AND ADJUSTMENT section should be referred to periodically for normal servicing of equipment. All machines and equipment require systematic, periodic inspection and maintenance, if they are to perform satisfactorily, over a long period of time. The driver/extractor is primarily a vibrating machine and if not given the best of care, or if improperly used and maintained, it is self-destructive. Therefore, the unit should receive at least the same care and maintenance as other high quality construction equipment.

The second category is for parts reordering and it includes both a PARTS LIST and a pictorial drawing of the assembly, for easier determination of the required part. Refer to the ORDERING PARTS section of the PARTS LIST for more specific procedures regarding parts ordering. Adherence of the listed procedures will insure receipt of the required part(s) with the minimal amount of delay or error.

WARRANTY

INTERNATIONAL CONSTRUCTION EQUIPMENT STANDARD WARRANTY

International Construction Equipment (J&M) warrants new products sold by it to be free from defects in material or workmanship for a period of 90 days after date of delivery to the first user and subject to the following conditions:

J&M's obligation and liability under this WARRANTY is expressly limited to repairing or replacing, at J&M's option, any parts which appear to J&M, upon inspection, to have been defective in material or workmanship. Such parts shall be provided at no cost to the user, at the business establishment of J&M or the authorized J&M distributor of the product, during regular working hours. This WARRANTY shall not apply to component parts or accessories of products not manufactured by J&M and which may carry the warranty of the manufacturer thereof, or to normal maintenance (such as engine tune-up) or to normal maintenance parts (such as oil filters). Replacement or repair parts installed in the product covered by this WARRANTY are warranted only for the remainder of the warranty, as if such parts were original components of said product. J&M COMPANY MAKES NO OTHER WARRANTY, EXPRESS OR IMPLIED, AND MAKES NO WARRANTY OF MERCHANTABILITY OR FITNESS, FOR ANY PARTICULAR PURPOSE.

J&M's obligation under this WARRANTY shall not include any transportation charges, cost of installation, duty, taxes or any other charges whatsoever, or any liability for direct, indirect, incidental, or consequential damage of delay. If requested by J&M, products or parts for which a warranty claim is made are to be returned, transportation prepaid to J&M. Any improper use, including operation after discovery of defective or worn parts, operation beyond rated capacity, substitution of parts not approved by J&M or any alteration or repair by others in such manner as in J&M's judgment affects the product materially and adversely, shall void this WARRANTY.

NO EMPLOYEE OR REPRESENTATIVE IS AUTHORIZED TO CHANGE THIS WARRANTY IN ANY WAY OR GRANT ANY OTHER WARRANTY UNLESS SUCH CHANGE IS MADE IN WRITING AND SIGNED BY AN OFFICER OF J&M.

TABLE OF CONTENTS

OPERATING INSTRUCTIONS

	<u>PAGE</u>
I. <u>GENERAL DESCRIPTION</u>	
A. General	I- 1
B. Vibrator	I- 2
C. Hydraulic Clamp	I- 2
D. Power Unit	I- 2
E. Remote-Control Pendant	I- 3
F. Specifications	I- 3
II. <u>PREPARATION FOR OPERATING</u>	
A. General	II- 1
B. Safety Precautions	II- 1
C. Rigging of Vibrator	II- 3
D. Connection of Hydraulic Clamp	II- 3
E. Connection of Hydraulic Hoses	II- 4
F. Bleeding Hydraulic Clamp Hoses	II- 6
G. Filling Vibrator Pressure Hose	II- 6
III. <u>OPERATING INSTRUCTIONS</u>	
Fig1 Control Panel with Remote Pendant	III- 1
A. Completion of Set-Up and Maintenance	III- 2
B. Control Panel	III- 2
C. Starting and Warming Up Engine	III- 3
D. Warming Hydraulic Oil	III- 3
E. Operation of Remote-Control Pendant	III- 4
F. Changing Frequency	III- 6
G. Shutdown	III- 6
IV. <u>MAINTENANCE AND ADJUSTMENTS</u>	
A. General	IV- 1
B. Daily	IV- 1
C. 100 Hours, 500 Hours and Other	IV- 2
D. Annually	IV- 2
E. Severe Conditions	IV- 3
F. Lubrication	IV- 3
G. Capacities	IV- 7
H. Draining and Filling Hydraulic Oil Reservoir	IV- 8
I. Changing Hydraulic Return Filter Element	IV- 8
J. Bolt Torque Information	IV- 9

TABLE OF CONTENTS

OPERATING INSTRUCTIONS (CONTINUED)

	<u>PAGE</u>
V. <u>HYDRAULIC CIRCUITRY</u>	
A. Hydraulic Clamp	V- 1
B. Vibrator Drive	V- 1
C. Auger Drive	V- 2
D. Hydraulic Impact Hammer	V- 2
E. Other	V- 3
Hydraulic Schematic	V- 4
F. Hydraulic Components List	V- 5
VI. <u>ELECTRICAL CIRCUITRY</u>	
A. Starting Diesel Engine	VI- 1
B. Stopping Diesel Engine	VI- 1
C. Safety Control System	VI- 1
D. Closing Hydraulic Clamp	VI- 2
E. Opening Hydraulic Clamp	VI- 2
F. Starting the Vibrator	VI- 2
G. Stopping the Vibrator	VI- 2
H. Other	VI- 3
Electrical Layout	VI- 4
Electrical Schematic	VI- 5
J. Electrical Components List	VI- 6
<u>PARTS LIST</u>	
VII. <u>GENERAL DATA</u>	
A. Abbreviations	VII- 1
B. Screws and Bolts	VII- 1
C. Serial Number Locations	VII- 2
VIII. <u>ORDERING PARTS</u>	
A. Procedure	VIII- 1
B. Fitting Description Key	VIII- 2
Fitting Style Selector Chart - SC1	VIII- 3
C. Hose Description Code	VIII- 4
D. Parts Identification	VIII- 5
Parts Lists and Drawings	VIII- 6
E. Miscellaneous Accessories	VIII-36
F. Recommended Spare Parts	VIII-39
G. Recommended Tightening Torque	VIII-41

I. GENERAL DESCRIPTION

A. GENERAL

The J&M Model J11 is a medium-frequency vibratory pile driver/extractor designed to drive and extract sheet piles, pipe, timber piles and concrete piles, caisson pipe and H, I and wide-flange beams.

The Model J11 operates in a frequency range of 900 to 1900 vibrations per minute to provide maximum pile penetration rates in a wide variety of soils. The unit has an eccentric moment of 1100 inch-pounds (12.7 kg-M) and produces a maximum amplitude of .94 inch (24mm).

The vibratory driver unit consists of two major components. (1) The vibrator with attached clamp and (2) the power unit with remote control pendant.

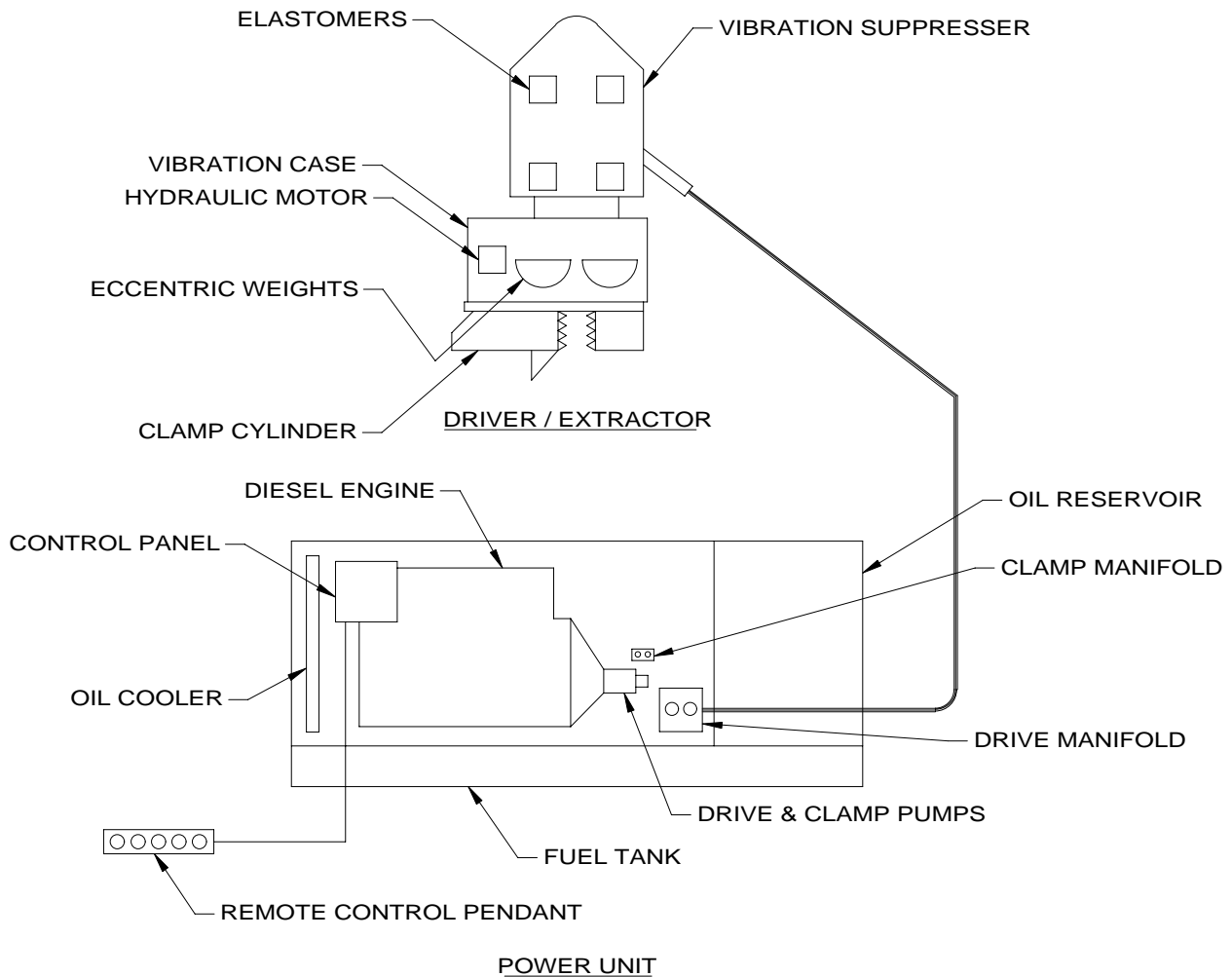

I. GENERAL DESCRIPTION

B. VIBRATOR

The vibrator consists of two major components. (1) The vibration case and (2) the vibration suppressor.

The vibration case contains two eccentric weights which rotate in a vertical plane to create vibration. The eccentric weights are driven by a hydraulic motor mounted on the vibration case. The motor and two eccentrics are all gear connected to maintain proper synchronization. The eccentric and motor shafts are mounted in heavy-duty cylindrical roller bearings. Lubrication is provided by a splash system activated by the rotating eccentrics and gears.

A suppressor assembly is mounted to the top of the vibration case, to isolate vibration from the crane and permit pile extraction. A heavy, outer suppressor, housing is connected to the vibration case by eight (8) rubber elastomers. The normal maximum line pull during extraction is 20 tons (178kN), but as an option, it can be assembled for a 30 tons (267kN) or 40 tons (356kN) maximum line pull.

C. HYDRAULIC CLAMP

A hydraulic clamp, bolted to the bottom of the vibration case, transmits vibration to the piling. The hydraulic clamp contains two gripping jaws; one fixed and one moveable. A large hydraulic cylinder operates the moveable jaw with 80 tons (712kN) of force to grip the pile. Clamping and un-clamping occurs in a few seconds.

D. POWER UNIT

The Model 230, power unit for the Model J11 vibrator, is powered by a Caterpillar 3116 DITA diesel engine. The diesel engine develops 220 HP (164kW) at 2600 RPM, and drives the dual hydraulic pumps that create the hydraulic power to operate the vibrator motor and hydraulic clamp.

The totally enclosed power unit is mounted on a skid-type fuel tank sub-base. A Control panel at the side of the unit contain all operating gages and controls. A common reservoir supplies hydraulic oil for the dual hydraulic pumps.

Three hydraulic hoses, 100 feet (30.5m) in length, connect the power unit to the hydraulic motor on the vibrator. Two other hydraulic hoses run from the power unit to the hydraulic clamp.

I. GENERAL DESCRIPTION

E. REMOTE-CONTROL PENDANT

The vibrator is operated by a hand-held remote control pendant. The pendant has three, two-way switches, one light and one push button. One switch (SLOW-FAST) raises and lowers the diesel engine speed. The second switch (REVERSE-FORWARD) starts and stops the vibrator. The other switch (OPEN-CLOSE) operates the hydraulic clamp. The light indicates that adequate clamping pressure exists for vibration to begin. The (red mushroom) push button (EMERGENCY STOP) shuts down the diesel engine instantly, in the event of an emergency. Note: Controls are duplicated on the power unit control panel in case the pendant is damaged. (See pg.III-5, Section E-e)

F. SPECIFICATIONS

1. Constant improvement and engineering progress make it necessary that we reserve the right to make specification changes without notice.

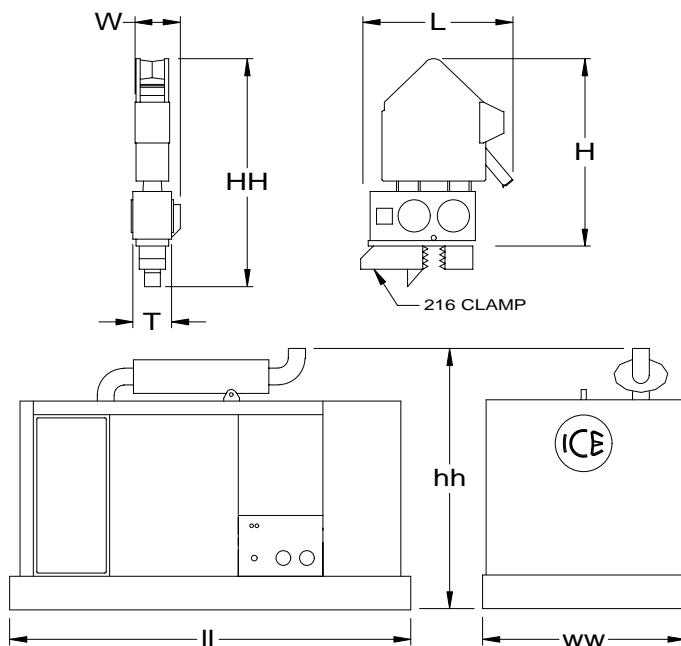

2. MODEL J11 VIBRATOR
(with hydraulic clamp)

Type.....	Hydraulic
Eccentric Moment.....	1100 In-lbs.(12.7kg-M)
Frequency.....	900-1900 VPM
Amplitude.....	0.94 in. (24mm)
Pile Clamping Force	80 Tons (712kN)
Max. Line Pull for	
Extraction.....	40 Tons (356kN)
Suspended Weight with Clamp and	
half hoses	5,525 lbs. (2506kg)
Length [L]	58.5 in. (149cm)
Width [W].....	18.1 in. (46cm)
Throat Width [T].....	13.3 in. (33.8cm)
Height with Clamp [HH].....	87.7 in. (223cm)
Height without clamp [H]	69 in. (175cm)

3. MODEL 230 POWER UNIT

Type.....	Diesel
Engine	CAT 3116DITA
Horsepower (2600 RPM).....	220 (164kW)
Weight	9,400 lbs. (4264kg)
Length [II]	126in. (320cm)
Width [ww]	60in. (152cm)
Height [hh]	75.5in. (192cm)

II. PREPARATION FOR OPERATION

A. GENERAL

When unloading and unpacking the vibratory driver, use extreme care. For your protection, make a thorough inspection of the unit immediately on delivery. In case of any damage or shortage, notify the transit agent at once and have the delivering carrier make a notation on the freight bill.

B. SAFETY PRECAUTIONS

Safety is basically common sense. There are standard safety rules, but each situation has its own peculiarities which can not always be covered by rules. Therefore, your experience and common sense will be your best guide to safety. Be ever watchful for safety hazards and correct deficiencies promptly.

Use the following safety precautions as a general guide to safe operations:

1. Read this manual thoroughly before operating or working on the equipment.
2. Read and follow any safety instructions in the CATERPILLAR engine operators manual.
3. Only well trained and experienced personnel should attempt to operate or maintain this equipment.
4. Never adjust, lubricate or repair the unit when it is in operation, or lifted above ground level.
5. Never remove, paint over or cover warning or safety labels. If labels become damaged or unreadable, replace immediately.
6. All personnel should wear approved safety clothing, including **HARD HATS, SAFETY SHOES, SAFETY GLASSES** and **HEARING PROTECTION** when in the vicinity of this machinery.
7. Do not stand any closer to this equipment than necessary when it is in operation. Parts may loosen and fall. Never stand under operating, or elevated, equipment.
8. When maintaining or repairing the equipment, never substitute parts not supplied, or approved in writing, by J&M.
9. Do not weld, or flame cut, on this equipment.
10. Never use or store flammable liquids on or near the engine.
11. Insure that all lifting equipment, including cranes, wire rope, slings, hooks, shackles, etc., are properly sized for the worst case loads anticipated during operations.
12. If there are any questions about the weights, specifications, or performance of the unit, contact J&M before handling or operating the equipment.
13. If the equipment is to be used for anything other than driving or extracting plumb piles, contact J&M before using the unit.
14. Check wire rope clips for tightness, and check wire ropes for wear, daily.
15. Insure that ground vibrations will not damage or collapse adjacent structures or excavations.
16. Remove all tools, parts and electrical cords before starting the unit.
17. When operating in an enclosed area, pipe exhaust fumes outside. Continued breathing of exhaust fumes may be fatal.

II. PREPARATION FOR OPERATION

B. SAFETY PRECAUTIONS (CONTINUED)

18. When servicing batteries, do not smoke or use open flames in the vicinity. Batteries generate explosive gas during charging. There must be proper ventilation when charging batteries.
19. When filling fuel tank, do not smoke or use open flame in the vicinity.
20. If abnormal equipment operation is observed, discontinue use immediately and correct the problem. Do not leave the equipment control pendant (radio control) unattended.
21. Store oily rags in approved containers, and away from engine exhaust system.
22. Make sure that the vibrator is OFF before starting the power unit engine.
23. Do not adjust, or set, hydraulic pressures higher or lower than those specified in this manual.
24. Never operate this equipment with hydraulic hoses that are damaged or "kinked". Replace damaged hoses immediately.
25. Do not lift, or support, hydraulic hoses with wire rope slings.
26. Never attempt to connect quick disconnects when the power unit is running.
27. Do not pull on, or attempt to move equipment, with hydraulic hoses.
28. Do not attempt to locate hydraulic leaks with your hands. High pressure hydraulic leaks can penetrate the skin, causing severe damage, blood poisoning and infection. Do not attempt to repair leaks while the equipment is in operation.
29. Do not attempt to tighten, or loosen, fittings or hoses when the machine is in operation.
30. Power unit must always be placed on level, stable, ground.
31. Do not remove power unit heat shields, or operate power unit without heat shields. Severe fires may result.
32. A properly maintained fire extinguisher, suitable for oil fires, must be kept in the immediate vicinity of equipment operations.
33. When moving or transporting this equipment, insure that the vehicle or vessel is of sufficient capacity to handle the load, and that the equipment is properly tied down.
34. When moving or transporting this equipment, be sure that quick disconnect dust caps are tight, and that cap safety cables are in place. Be sure that all equipment parts are tight, or properly secured, before shipment. Unsecured parts may vibrate loose and fall, during transport, causing injury or property damage.
35. Keep crane boom, piles, leads, wire rope and other equipment at least 15' (5M) from electrical power lines, transformers and other electrical equipment, or at such distance as required by applicable safety codes.
36. Rounded or damaged bolt heads or nuts should be replaced so that proper torque values may be obtained. Proper torque values are necessary to prevent parts on this equipment, leads and crane boom from loosening and falling. Refer to Torque Chart, in this manual, for proper values.
37. Do not use the vibrator clamp to move piles. Loss of hydraulic pressure could cause piles to fall.

II. PREPARATION FOR OPERATION

B. SAFETY PRECAUTIONS (CONTINUED)

38. Never clamp vibrator to pile and disconnect the crane line. Loss of hydraulic pressure could cause vibrator to fall. Lay vibrator down when not in use.
39. When extracting piles, always attach a safety line between pile and crane hook.
40. When extracting piles, check crane load/radius tables to be sure crane capacity is adequate for maximum allowable extraction pull.
41. When extracting piles, or any other driving operations, always be sure that the crane line is aligned with the centerline of the pile. Do not side load crane boom or vibrator. Dangerous crane boom, or vibrator, damage may result.
42. When extracting piles, do not exceed the capacity of the vibrator suppressor. Continued operation against the safety stops will cause damage to the crane boom and the vibrator.
43. Never induce line pull on a vibrator before starting the unit in vibration. Always start both driving and extraction of piles with a slack line.
44. Keep hands away from clamp jaws.
45. Keep hands away from vibrator suppressor during operation. Clearances may change causing pinch points.
46. Do not run vibrator unless clamp jaws are closed.
47. Use tag line to control vibrator whenever possible.
48. When driving "batter" piles, insure that the leads, and crane boom, have sufficient bending strength to handle the worst case load. Consult J&M.
REMEMBER, SAFETY IS EVERYONE'S BUSINESS.

C. RIGGING OF VIBRATOR

A steel wire rope sling must be connected to the lifting pin of the vibration suppressor. The required strength of this sling depends on the capacity of the crane and the work to be carried out. A safety factor of five is recommended. Several turns of a smaller diameter cable will usually last longer than one turn of a larger diameter cable.

D. CONNECTION OF HYDRAULIC CLAMP

The vibrator is usually shipped with the hydraulic clamp already attached.

If the clamp is not attached, it will be necessary to attach it to the bottom of the vibrator. Orient the clamp to the vibrator with the clamp cylinder end (movable jaw) at the opposite end of the vibrator as the hose chute is mounted. All eight (1.5-6UNC x 11.00) bolts and six (1.5-6UNC x 12.00) bolts must be in place and torqued to approximately 2800 ft-lbs (387 Kg-M). One (1.00-8UNC x 4.00) bolt must be in place and torqued to approximately 1009 ft-lbs (139.4 Kg-M).

For caisson work, the caisson beam must be attached to the bottom of the vibrator and tightened as above. Then slide the clamps into position on the caisson beam.

II. PREPARATION FOR OPERATION

E. CONNECTION OF HYDRAULIC HOSES

1. Connection of hoses at power unit.

- a. The vibrator and hydraulic clamp are connected to the power unit by five hydraulic hoses. (Fig. 1)

CAUTION: The power unit must be shut down during connection of the hydraulic hoses.

- b. The hoses connect to the power unit with quick-disconnect couplers. Hose couplers are arranged to insure correct connections at the power unit. See the diagram (Fig. 1) for correct hose connection.
- c. Clean couplers with a lint-free cloth before making connections.
- d. Make sure that the couplers are fully run up. They should be fully hand tight. Do not use wrenches to tighten.

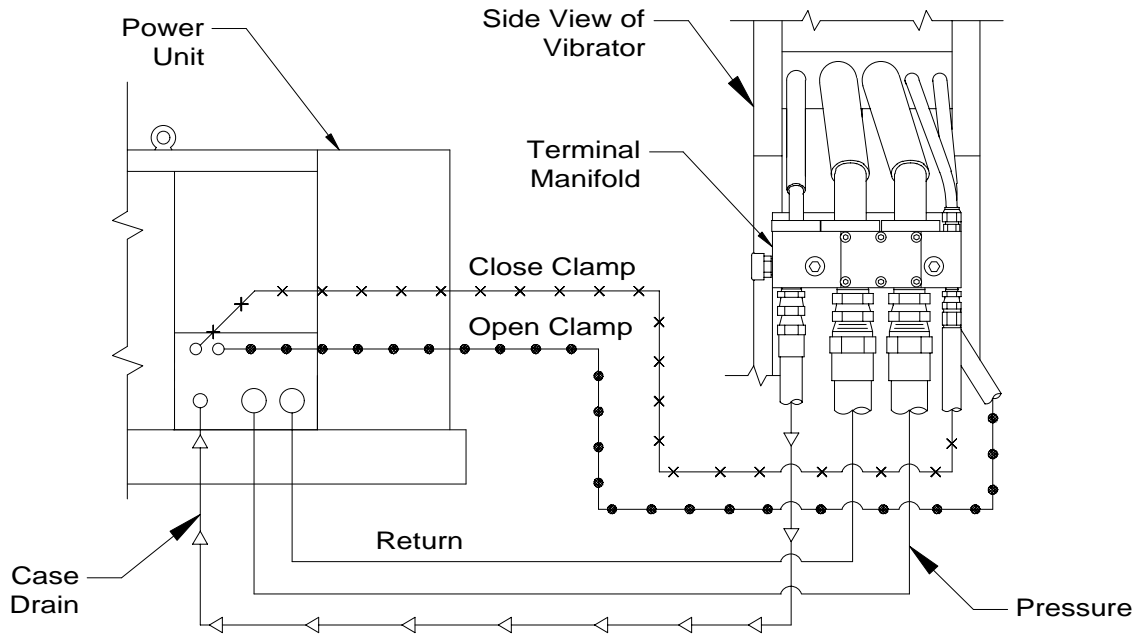

(Fig. 1)

II. PREPARATION FOR OPERATION

E. CONNECTION OF HYDRAULIC HOSES (CONTINUED)

2. Connection of hoses at vibrator.

- a. The vibrator is usually shipped with the hoses attached to the vibrator. If the hoses have been shipped separately, they must be connected in the field. Fig. 1 shows the correct arrangement of the five hoses connecting the power unit to the vibrator.

CAUTION: Starting the vibrator with the hoses reversed will result in low power or possible ruptured hoses.

- b. The vibrator is usually shipped with the hydraulic clamp and hoses attached. If the clamp has been shipped separately, the two hoses connecting the clamp to the vibrator must be connected. Fig. 2 shows the correct arrangement of these hoses.

For caisson clamps, four hoses must be connected. The two o-ring - jic fittings on the terminal manifold must be removed and replaced by two tees. This allows the four hoses to run to both sides of the vibrator and operate the caisson clamps. The terminal manifold is stamped O and C (O for Open Clamp) (C for Close Clamp).

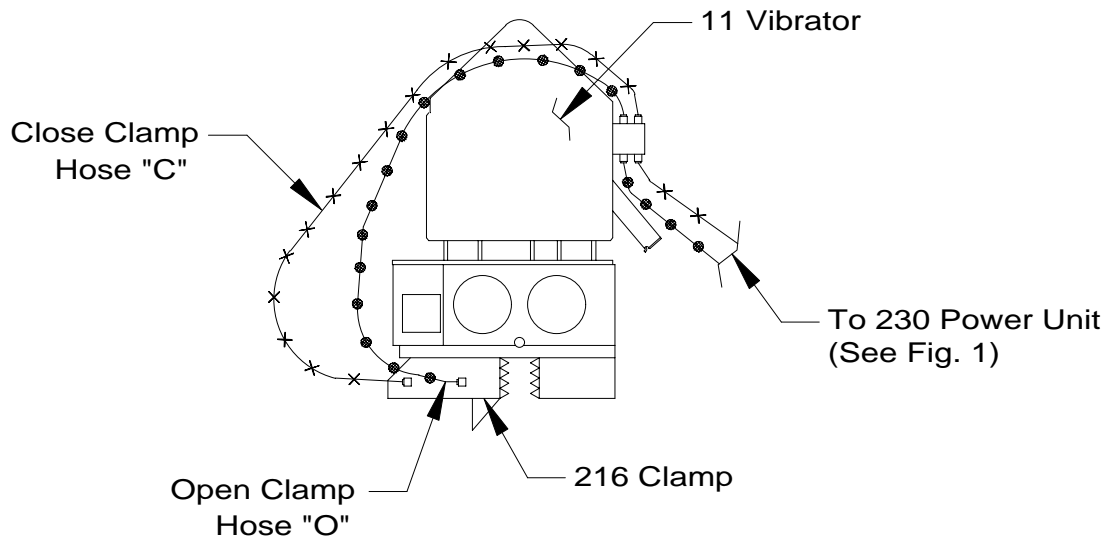

(Fig. 2)

II. PREPARATION FOR OPERATION

F. BLEEDING HYDRAULIC CLAMP HOSES

1. When the vibrator and hydraulic clamp are shipped with all hoses attached (between vibrator and clamp and five main hoses connected to the vibrator), the hoses are usually full of oil and may be used immediately. However, if any of the clamp hoses are connected at the job site or if air is present in hoses, they must be bled prior to operation.
2. Read SECTION III - OPERATING INSTRUCTIONS.
3. Start and warm up the diesel engine in accordance with SECTION III-C - STARTING AND WARMING UP ENGINE.
4. With the engine warmed-up and running at 1500 RPM, loosen the close-clamp line at the hydraulic clamp. Turn the clamp switch on the remote-control pendant to CLOSE. Wait until oil flows from the connection at the hydraulic clamp. When oil flows without air, tighten the connection.
5. After the line has been bled, alternately turn the clamp switch to CLOSE and OPEN to insure that the clamp is working properly. It may be necessary to bleed the line more than once. The open-clamp line may also require bleeding.

G. FILLING VIBRATOR PRESSURE HOSE

1. The vibrator is usually shipped with the vibrator hydraulic hoses full of oil and the unit may be used immediately. However, if the pressure hose has been removed from the vibrator, the hose should be allowed to fill with hydraulic oil prior to full speed operation.
2. Read SECTION III - OPERATING INSTRUCTIONS.
3. Start and warm up the diesel engine in accordance with SECTION III-C - STARTING AND WARMING UP ENGINE. Hold the vibrator in a vertical position.
4. With the engine warmed up and running at 1000 RPM, turn and hold the vibrator switch REVERSE. The hoses will fill in approximately 5 minutes. CAUTION: If vibration begins in the vibrator, stop immediately and recheck hose connections.

III. OPERATING INSTRUCTIONS

CONTROL PANEL WITH REMOTE CONTROL-PENDANT

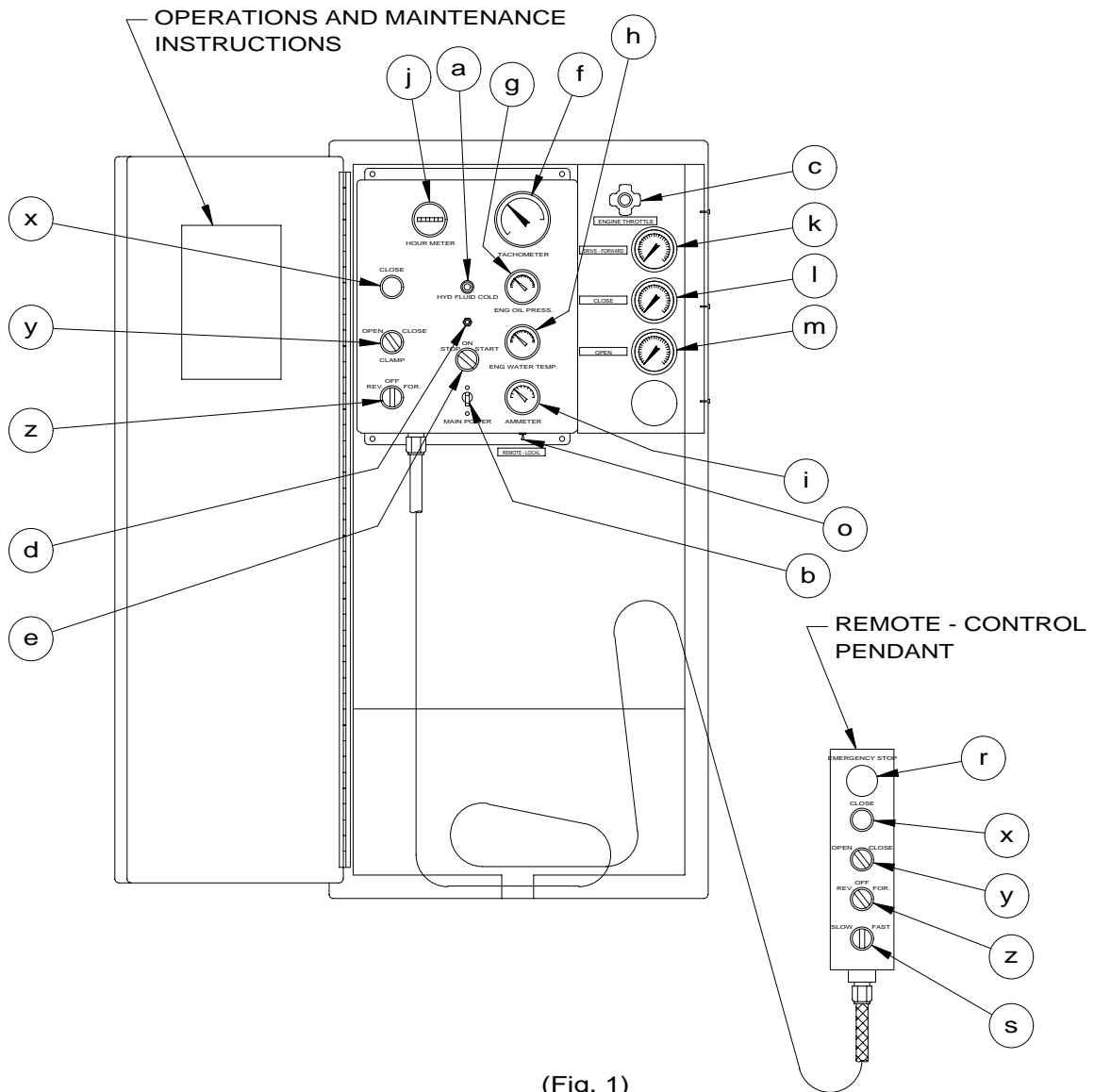

(Fig. 1)

III. OPERATING INSTRUCTIONS

A. COMPLETION OF SET-UP AND MAINTENANCE

1. Complete all preparation as described in Section II.
2. Read Section IV - MAINTENANCE AND ADJUSTMENTS and perform any required maintenance.

B. CONTROL PANEL

1. The control box (Fig. 1, page III-1) at the side of the power pack contains the controls and gages for the diesel engine, vibrator, and the OPERATION AND MAINTENANCE INSTRUCTIONS.
2. Control panel contains the following controls and gages:
 - a. Hydraulic fluid cold light - comes on if hydraulic oil is below 70°F (21°C).
 - b. Main power switch (Circuit Breaker) - on/off switch for 24 volt electrical power. Must be "ON" for the vibrator to run.
 - c. Engine throttle
 - d. Engine shut-down reset button - on start must be held in until oil pressure exceeds 30 PSI.
 - e. Engine "ON/OFF/START" switch - for diesel engine.
 - f. Engine tachometer
 - g. Engine oil pressure gage
 - h. Engine water temperature gage
 - i. Engine ammeter
 - j. Engine hourmeter
 - k. Pressure gage - (Drive - Forward/Reverse)
 - l. Pressure gage - (Close)
 - m. Pressure gage - (Open)
 - o. Remote-Local switch
 - r. Emergency Stop - Push to stop engine
 - s. Electric Throttle
 - x. Clamp light
 - y. Clamp switch
 - z. Vibrator switch
3. The OPERATION AND MAINTENANCE INSTRUCTIONS on the control panel door are there as reminders only. They are not intended to substitute for a thorough understanding of the Operators Manual.

C. STARTING AND WARMING UP ENGINE

1. Before starting the engine, read the CATERPILLAR OPERATION GUIDE carefully. Follow the engine starting, operating and maintenance procedures in that manual.
2. The diesel engine should not be started if the temperature of the hydraulic oil is below 0°F (-18°C). The temperature may be read on the gage on the hydraulic reservoir. If ambient temperatures below 0°F (-18°C) are anticipated, an immersion heater for the hydraulic oil is available. Consult J&M for details.
3. The MAIN POWER SWITCH on the control panel should be ON. The vibrator switch (FOR/REV) on the control pendant should be in the neutral position. (The engine will not start if switch is not in neutral)
4. Pull out the ENGINE THROTTLE about half way. Press the button on the end of the throttle for adjustment.
5. Hold SHUTDOWN RESET button in and turn the ENGINE START switch to START position. If the engine fails to start after 30 seconds of cranking, allow the starter to cool for two minutes before repeating the starting procedure.
6. As the engine starts, release the ENGINE START switch. It will return to the RUN position.
7. Adjust the throttle until the engine is running at 1500 RPM, and allow it to warm-up for five minutes.
8. Allow the temperature of the hydraulic oil to come up to at least 30°F (-1°C) before starting vibrator.

D. WARMING HYDRAULIC OIL

1. The vibrator should not be operated at full speed if the temperature of the hydraulic oil is below 70°F (21°C). The HYDRAULIC FLUID COLD light on the control panel will be on if oil temperature is below 70°F (21°C). Also check gage on reservoir.
2. If temperature of the hydraulic oil is below 70°F (21°C), set the diesel engine at 1500 RPM and run the vibrator at reduced speed until the temperature of the hydraulic oil exceeds 70°F (21°C). The Hydraulic Fluid Cold light will then go off.

III. OPERATING INSTRUCTIONS

D. WARMING HYDRAULIC OIL (CONTINUED)

3. When the engine is warmed up and hydraulic oil temperature is at least 70°F (21°C), full speed operation may begin. Adjust the throttle so the engine is running at 2640 RPM unloaded. The engine should maintain about 2400 RPM under load.

CAUTION: Do not operate the vibrator if hydraulic oil temperature exceeds 160°F (71°C) as this may damage hydraulic components.

E. OPERATION OF REMOTE-CONTROL PENDANT

1. The operation of the vibratory driver is controlled by the remote-control pendant. The pendant is connected to the control cabinet with 50 feet of electrical cable to permit operation from any advantageous position to view the vibrator. (Consult J&M for pendant extensions)
2. The pendant has three, two-way switches, an indicator light and an Emergency Stop button.

a. To Clamp to Pile:

Position vibratory driver on pile. Turn the clamp switch on the pendant to CLOSE. The CLAMP light on the pendant will come on when the hydraulic clamp has achieved adequate pressure to permit vibration to begin. The light should normally come on in a few seconds.

b. To Start Vibration:

Adjust the throttle so the engine is running at an RPM to maintain desired VPM. See chart on page III-6.

Turn the vibrator switch to FORWARD.

NOTE: The vibrator switch reads FORWARD/REVERSE instead of START/STOP because the Model 230 power unit also operates J&M earth augers.

CAUTION: Do not turn the switch to FORWARD until the CLAMP light in the pendant comes on, indicating adequate clamping pressure.

III. OPERATING INSTRUCTIONS

E. OPERATION OF REMOTE-CONTROL PENDANT (CONTINUED)

c. To Stop Vibration:

Turn the vibrator switch to OFF.

NOTE: Turning the switch to REVERSE will not cause damage, and will decrease stopping time.

d. To Unclamp from Pile:

Turn the CLAMP switch to OPEN to release the hydraulic clamp so that the vibrator can be moved from the pile. Hold the CLAMP switch in the open position until the jaws are fully open.

CAUTION: Do not turn the switch to OPEN until a visual check indicates that vibration has stopped.

e. To change engine speed:

Turn the Throttle switch (SLOW-FAST) to SLOW and the engine speed will decrease. Turn the switch to FAST and the engine speed will increase. Momentarily turning the throttle switch to FAST or SLOW during operations will adjust engine speed, and therefore vibrator speed, to facilitate the desired penetration rate.

f. Emergency stop button:

Push the EMERGENCY STOP button in and all operating functions will cease to operate. Diesel engine and vibrator will stop immediately.

g. If the remote control pendant is damaged or the pendant line is cut, you may still operate the vibrator by using the control switches on the control panel (See Fig. 1 on page III-1 items X, Y, Z). On the lower right bottom of the control panel there is a switch labeled "REMOTE-LOCAL". Turn the switch to LOCAL and the switches on the control panel will be functional, and the Remote Control Pendant will be disabled. Engine speed must be adjusted manually.

III. OPERATING INSTRUCTIONS

F. CHANGING FREQUENCY

1. In order to provide maximum flexibility in achieving optimum pile penetration and extraction rates, the frequency of the vibratory driver is adjustable.
2. The frequency can be varied from 900 to 1900 vibrations per minute by changing engine speed. Engine speed is changed with the ENGINE THROTTLE on the control panel or electric throttle switch (SLOW-FAST) on the remote control pendant. Vibrator frequency corresponds to engine speed according to the table shown below:

<u>ENGINE RPM</u>	<u>VIBRATOR VPM</u>
2600	1900
2400	1750
2100	1530
1800	1320
1500	1100
1200	900

G. SHUT DOWN

1. Stop the vibrator.
2. Allow the diesel engine to run for five minutes at 1500 RPM.
3. Reduce speed to low idle for about thirty seconds.
4. Stop the engine by turning the ENGINE START switch to OFF. (Engine may also be stopped by pushing in the EMERGENCY STOP button on the Remote Control Pendant.)

CAUTION: If the diesel engine is shut down while the vibrator is clamped to a pile, the clamp check valve will keep the vibrator clamped to the pile. However, system leakage could result in a loss of clamp pressure over time. Therefore, it is not recommended to leave the vibrator clamped to a pile when the diesel engine is not running.

IV. MAINTENANCE AND ADJUSTMENTS

A. GENERAL

Preventive maintenance includes normal servicing that will keep the vibratory driver, clamp and power unit in peak operating condition and prevent unnecessary trouble from developing. This servicing consists of periodic lubrication and inspection of the moving parts and accessories of the unit.

Lubrication is an essential part of preventative maintenance, controlling to a great extent the useful life of the unit. Different lubricants are needed and some components in the unit require more frequent lubrication than others. Therefore, it is important that the instructions regarding types of lubricants and frequency of their applications be closely followed.

To prevent minor irregularities from developing into serious conditions that might involve shut-down and major repair, several other services or inspections are recommended for the same intervals as the periodic lubrications. The purpose of these services or inspections is to assure the uninterrupted operation of the unit.

Thoroughly clean all lubrication fittings, caps, filler and level plugs and their surrounding surfaces before servicing. Prevent dirt from entering with lubricants and coolants. The intervals given in the schedule are based on normal operation. Perform these services, inspections, etc., more often as needed for operation under abnormal or severe conditions.

B. DAILY

1. Check the entire unit prior to and during set-up each day or at the beginning of each shift.
2. Prior to starting the power unit or at the beginning of each shift, check the following items:
 - a. Visibly inspect all bolts, nuts and screws, including the bolts fastening the hydraulic clamp to the vibration case, to insure they are tight. **IMPORTANT:** vibration loosens bolts- check carefully.
 - b. Tighten bolts holding gripping jaws to the hydraulic clamp.
 - c. Grease plunger in hydraulic clamp with any good multi-purpose grease.
 - d. Check the oil level in the vibration case and add oil if required. The oil level should be in the middle of the sight glass. Change oil if milky or contaminated. **DO NOT OVERFILL**
 - e. Check the oil level in the hydraulic reservoir and refill if necessary.

CAUTION:It is absolutely imperative that no dirt or other impurities be permitted to contaminate the hydraulic oil. Any contamination will drastically shorten the life of the high-pressure hydraulic system.

IV. MAINTENANCE AND ADJUSTMENTS

B. DAILY (CONTINUED)

- f. Visually check all hoses for signs of damage or cuts that might cause hose failure during operation. Be sure all connections are tight, especially the quick-disconnect couplers.
 - g. Visually inspect all suppressor elastomers.
 - h. Electrical components need no maintenance except periodic wiping with a clean, dry, lint-free cloth to remove dust.
 - i. Perform all daily maintenance checks and lubrication indicated in the CATERPILLAR OPERATION GUIDE.
3. After engine start-up, check the following:
- a. Check all hydraulic hoses for leaks. Make sure they hang freely with no kinks.
 - b. Check pump and all hydraulic manifolds for leaks.
 - c. Check the filter indicators. 0-17psi = Filter Clean, 18-23psi = Change Filter, 24 + psi = Filter Clogged The return filter on the power pack must be checked with the diesel engine running at full speed.

C. 100 HOURS, 500 HOURS AND OTHER

- 1. Every 100 hours, drain and add new lubricant in the vibration case.
- 2. Perform all maintenance checks and lubrication indicated in the CATERPILLAR OPERATION GUIDE.

D. ANNUALLY

Have the hydraulic oil tested by a local hydraulic service center or oil company. Replace if required.

NOTE: The frequency with which hydraulic oil requires changing depends both on the condition of the oil and the operating conditions involved. The most accurate method for determining how often oil should be changed is to have a laboratory oil analysis done periodically.

IV. MAINTENANCE AND ADJUSTMENTS

E. SEVERE CONDITIONS

The servicing intervals specified are based on normal operating conditions. Operation under severe or unusual conditions will require some adjustments in servicing intervals.

1. When the average temperature is above 80°F (26°C) or below -10°F (-23°C), reduce service time intervals by one-half of those specified above.
2. When operating in the presence of dust or sand, reduce service time intervals by one-half of those specified.
3. When operating in excess of twelve hours per day, reduce service time intervals by one-half of those specified.
4. When operating in air with high salt or moisture, the servicing intervals need not usually be changed. However, the unit should be inspected weekly to determine if additional servicing be required. Also, have hydraulic oil tested quarterly.
5. For extended inactive periods, the engine should be started at least once a week and run until thoroughly warm. Servicing time intervals may be extended from those specified, but for actual time intervals, contact you local Caterpillar dealer, especially during lengthy storage periods.

F. LUBRICATION

1. Crankcase (Diesel Engine)
 - a. Follow the engine manufacturer's maintenance schedule and the lubricating oil specifications outlined in the CATERPILLAR OPERATION GUIDE.
 - b. The lubricant shall meet the performance requirements of API Service Classifications CD or MIL-L-2104C.
 - c. New engines are shipped with ASHLAND 400M + HDT 15W-40 but the following multi-grade crankcase oils are acceptable for use or replacement in normal operation (10°F to 90°F) (-12°C to 32°C).

IV. MAINTENANCE AND ADJUSTMENTS

F. LUBRICATION (CONTINUED)

AMOCO	- 15W-40	300
ARCO	- 15W-40	Fleet S3 Plus
BORON (BP)	- 15W-40	Vanellus C Extra
CHEVRON	- 15W-40	Delo 400
CITGO	- 15W-40	C500 Plus
CONOCO	- 15W-40	Fleet Supreme
EXXON	- 15W-40	XD3
GULF	- 15W-40	Super Duty Plus
MOBIL	- 15W-40	Delvac Super
PHILLIPS	- 15W-40	Super HD II
SHELL	- 15W-40	Rotella T
SUN	- 15W-40	Sunfleet Super C
TEXACO	- 15W-40	Ursa Super Plus
UNION	- 15W-40	Guardol
VALVOLINE	- 15W-40	All Fleet

- d. For operation in extreme sub-zero climate, refer to the CATERPILLAR OPERATION GUIDE Crankcase Lubricating Oils or contact the nearest Caterpillar representative. (CAT bulletin #SEBU5898-06)

2. Hydraulic System

To maintain the maximum operating efficiency in the precision parts of the hydraulic system, it is extremely important to eliminate factors which can cause breakdowns or unsatisfactory performance. Among the most common of these factors are rust, corrosion, contamination and products of oil deterioration. Most problems can be minimized or avoided simply by maintaining a disciplined preventive maintenance program.

Some simple steps to follow as part of that program are:

- a. Keep stored oil dry and clean at all times and always store in clean containers.
- b. Always clean tools, spouts, lids, funnels, etc. when used in conjunction with the transfer of oil.
- c. Never put dirty oil into the hydraulic system. Use only clean, uncontaminated oil of the types recommended below. Never return to the system any oil which has leaked out.
NOTE: Foreign material in the hydraulic system can drastically effect the life and operation of many hydraulic component parts.
- d. Clean or replace filter elements at the first indication that they are dirty or ineffective.

IV. MAINTENANCE AND ADJUSTMENTS

F. LUBRICATION (CONTINUED)

Mixing of different manufacturers' hydraulic oil is not recommended. However, it can be done if the oils are miscible (contain the same base and additive). It may be necessary to contact an oil supplier to determine this.

New power units are shipped with CHEVRON Clarity AW46 hydraulic oil. This oil exceeds the requirements of both the E.P.A. and U.S. Fish and Wildlife Service for non-toxicity and is inherently biodegradable. Adding any other oil from the list below, will contaminate the Clarity oil and the system will no longer be environmentally friendly.

Should the customer choose to use an alternate oil, the following recommendations may be used when replacing oil in the hydraulic system.

FIRST Preference Group:

CHEVRON	Clarity AW46
MOBIL	DTE-15
SUN	2105

SECOND Preference Group:

ARCO	Duro AW46
CHEVRON	Hydraulic AW46
PHILLIPS	Magnus A46
SHELL	Tellus 46

THIRD Preference Group:

BORON	Energol HLP46
CITGO	A.W. Hydraulic 46
CONOCO	Super 46
EXXON	Nuto H46
GULF	Harmony 46AW
SUN	Sunvis 846
TEXACO	Rando HD AZ46
UNION	Unax AW46

Whenever oils from the second preference group are used, it is necessary to test the oil more often to insure that viscosity remains within recommended limits while in service. Using oils from the third preference group requires even a more discerning inspection than use of oils from the second group.

The recommended oils were chosen based on the hydraulic system operating temperature range being 5°F (-15 °C) (cold ambient start-up) to 160°F (71°C) (maximum operating).

IV. MAINTENANCE AND ADJUSTMENTS

F. LUBRICATION (CONTINUED)

When operating in arctic conditions, it is recommended to use an immersion heater to pre-heat the oil prior to starting . Contact J&M for other arctic operating procedures. It may also be necessary in extremely cold or hot climates to use a different viscosity oil which is better adapted to adverse conditions. Contact the nearest oil supply representative for suggested procedures.

CHEVRON Clarity AW46 hydraulic oil is available from J&M in five gallon cans. See SECTION VIII - ORDERING PARTS, page VIII-40.

3. Vibration Case

The oil level is easily read through the sight glass located at the lower center of the vibration case on the motor side. Lubricating oil may be added when necessary, through the hole in the vibration case top plate after removing the 1" pipe plug. To drain the case, remove the 3/4" pipe plug at the end of the base plate. Tilt the case for complete drainage.

The preferred lubricating oil for J&M vibration cases is "High Moly" oil (Schaeffer 268). Longer intervals between oil changes and fewer maintenance hours spent on mechanical service can generally be realized with this oil.

Therefore, whenever the "first preferred" oil is not available, or desired, and an alternate oil is selected, it will be necessary to test and/or change the oil at shorter intervals.

Extensive tests have indicated that the use of Schaeffer 268 results in cooler operation and extended bearing and gear life.

IV. MAINTENANCE AND ADJUSTMENTS

F. LUBRICATION (CONTINUED)

- a. The vibration case lubricant installed at the factory is Schaeffer 268 but the following gear lubes may be used when changing lubricants:

FIRST Preference Group:

SCHAEFFER 268

SECOND Preference Group:

MOBIL	SHC-634
BORON	Gearep 140
CHEVRON	Gear Comp. NL460
CITGO	Premium MP 85W-140
CITGO	Standard MP 85W-140
GULF	Lub 85W-140 Lub 85W-140
PHILLIPS	MP 85W-140
SHELL	Omala 460 Omala 460
SUN	Sunep 1110

THIRD Preference Group (Natural Petroleum Base):

AMOCO	Perma Gear EP140
ARCO	Pennant NL 460
CONOCO	EP 460
EXXON	Spartan EP 460
PHILLIPS	AP 140
TEXACO	Meropa 460
UNION	MP 85W-140
VALVOLINE	Gear Lub 85W-140

SCHAEFFER 268 Lubricant is available from J&M in five gallon cans. See SECTION VIII ORDERING PARTS, page VIII-40

G. CAPACITIES

- | | | |
|---------------------------------|-----|---------|
| 1. Diesel Engine Crankcase | 21 | Quarts |
| 2. Hydraulic System (Reservoir) | 275 | Gallons |
| 3. Vibration Case | 1.5 | Gallons |
| 4. Fuel Tank Sub-Base (Diesel) | 130 | Gallons |
| 5. Engine Cooling System | 40 | Quarts |

IV. MAINTENANCE AND ADJUSTMENTS

H. DRAINING AND FILLING HYDRAULIC OIL RESERVOIR

1. The Hydraulic reservoir is drained by removing a plug on the bottom of the reservoir.
2. The hydraulic reservoir is filled by the manual pump mounted on the back (engine side) of the reservoir. All oil is pumped to the reservoir through the returned filter (F2) to insure no dirt enters the hydraulic system.

I. CHANGING HYDRAULIC RETURN FILTER ELEMENTS

1. The return filters are located on the hydraulic reservoir above the hex key rack.
2. To remove the return filter elements, you must use a filter wrench capable of accepting a 5" diameter filter. (Available at your local auto-parts store.) Unscrew the return filter elements counterclockwise to remove. Remove both filter elements and gaskets from the filter housing.
3. Clean filter housing with a lint free rag.
4. Install the new gaskets to the new filter elements. Apply a light coating of multi-purpose grease to the top of each gasket.
5. Screw the return filter elements and gaskets clockwise onto the filter housing until the gaskets make contact to the filter housing base.
6. Using the filter wrench, tighten both return filter elements approximately 3/4 of a turn.
7. Repeat above with the other two return filters.
8. With four new return filter elements installed, start the power unit and run for approximately three minutes. CHECK FOR LEAKS.

IV. MAINTENANCE AND ADJUSTMENTS

J. BOLT TORQUE INFORMATION

The only way to actually tighten high strength bolts is with a calibrated torque wrench. Proper use of the torque wrench is important. To obtain the listed torques, a steady pull should be exerted to the handle until the desired torque is reached.

The following torque specifications apply to the bolts from the vibrator assemblies listed. Whenever any of these bolts, are replaced, the given torque specifications should be adhered to.

<u>VIBRATION SUPPRESSOR</u>		<u>Page VIII-6</u>
Item 41	5/16"-18	27 Ft-Lbs (3.7 Kg-M)
Item 30	3/8"-16	48 Ft-Lbs (6.6 Kg-M)
Item 33	7/16"-14	77 Ft-Lbs (10.6 Kg-M)
Item 10, 25	1/2"-13	119 Ft-Lbs (16.4 Kg-M)
Item 5, 18, 39	5/8"-11	233 Ft-Lbs (32.3 Kg-M)
Item 3, 53	3/4"-10	417 Ft-Lbs (57.6 Kg-M)
Item 63, 72	1"-8	1,009 Ft-Lbs (139.4 Kg-M)
Item 54, 56	1-1/2"-6	2,800 Ft-Lbs (387 Kg-M)

<u>VIBRATION CASE</u>		<u>Page VIII-10</u>
Item 26	7/16"-14	77 Ft-Lbs (10.6 Kg-M)
Item 16, 23, 32, 33	1/2"-13	119 Ft-Lbs (16.4 Kg-M)
Item 19	5/8"-11	233 Ft-Lbs (32.3 Kg-M)

V. HYDRAULIC CIRCUITRY (REFERENCE:HYDRAULIC SCHEMATIC PG V-4)

A. HYDRAULIC CLAMP

With the diesel engine running, hydraulic oil is taken from the reservoir by the clamp pump (P2). Prior to entering the clamp pump, the oil is filtered by the pick-up filter (F1). The clamp pump flow returns to the reservoir if the clamp switch on the pendant has not been moved. Returning oil is filtered by the return filter (F2).

Turning the clamp switch on the control pendant to CLOSE activates the CLAMP CONTROL VALVE (V1). Hydraulic oil is directed to the CLOSE CLAMP side of the hydraulic CYLINDER (CYL) in the hydraulic clamp. The clamp closes. Clamping pressure is indicated by the clamp pressure gage (GA-2). When clamping pressure reaches approximately 4400 PSI (303 Bar), the CLAMP PRESSURE SWITCH (PS) deactivates the clamp control valve (V1), which directs the flow from the clamp pump to the reservoir. Pressure at the clamp is maintained by the CLAMP CHECK VALVE (CV1). If clamping pressure falls below 4100 PSI (283 Bar), the CLAMP PRESSURE SWITCH activates the clamp control valve to restore pressure.

Turning the clamp switch on the control pendant to OPEN activates the CLAMP CONTROL VALVE (V1). Hydraulic oil is directed to the OPEN CLAMP side of the hydraulic cylinder. The pressure in the OPEN CLAMP line opens the CLAMP CHECK VALVE (CV1). The clamp opens. Pressure in the OPEN CLAMP line is indicated by the clamp pressure gage (GA-3).

Pressure in the clamping circuit is limited to 4500 (310 Bar) PSI by the clamp RELIEF VALVE (RV2). The quick-disconnect couplers (QD3 & QD4) permit decoupling of the clamp hoses at the power unit.

NOTE: Clamp pump may also be used to power some auxiliary functions. Contact J&M for information on "POWER BEYOND" modifications.

B. VIBRATOR DRIVE

With the diesel engine running, hydraulic oil is taken from the reservoir by the DRIVE PUMP (P1) and directed to the CONTROL MANIFOLD. Prior to entering the drive pump, the oil is filtered by the pick-up filter (F1). The drive pump flow returns to the reservoir through the RETURN FILTER (F2), if the vibrator switch on the pendant has not been moved.

V. HYDRAULIC CIRCUITRY

B. VIBRATOR DRIVE (CONTINUED)

Turning the vibrator switch, on the control pendant, to FORWARD activates the FORWARD SOLENOID on the CONTROL VALVE (V2), directing pump flow to the VIBRATOR MOTOR (M).

Full motor speed is reached within a few seconds and the motor drive pressure is indicated by GAGE (GA-1). Maximum drive pressure is limited to approximately 4500 PSI (310 Bar) by the RELIEF VALVE (RV1). Case drain oil from the motors returns to the reservoir. Case drain pressure is limited to 50 PSI by the case drain RELIEF VALVE (RV3).

Moving the vibrator switch, on the control pendant, to REVERSE activates the REVERSE SOLENOID on the CONTROL VALVE (V2). Pump flow is directed to the reverse side of the vibrator motor (M). The back pressure caused by forcing both the pump flow and the motor (M) exhaust flow through check valve (CV4) rapidly brakes the vibrator to a stop.

The quick-disconnect couplers (QD1, QD2, and QD5) permit de-coupling of the drive and case drain hoses at the power unit.

C. AUGER DRIVE

See J&M Auger Manuals for description of Hydraulic Control Manifold operation, in the "Auger Mode."

D. HYDRAULIC IMPACT HAMMER

To convert a 230 Power Unit to operate an J&M Hydraulic Impact Hammer, readjust RELIEF VALVE (RV2) to 1000 psi (69 Bar). **"NOT THE PRESSURE SWITCH"**

See J&M Hydraulic Impact Hammer Manual for complete Impact Hammer set up instructions.

V. HYDRAULIC CIRCUITRY

E. OTHER

Returning oil is filtered by the RETURN FILTER (F2). INDICATOR GAGE (GA5) shows condition of FILTER (F2).

A manual PUMP (MP) is provided to fill the hydraulic reservoir. A CHECK VALVE (CV2) prevents loss of oil from the reservoir back through this pump.

A TEMPERATURE SWITCH (TS) located in the reservoir operates the hydraulic oil cold light.

The HEAT EXCHANGER (HE) cools the hydraulic oil returning to the reservoir.

Motor cavitation is prevented in the braking operation by the CHECK VALVE (CV4).

Shut- off VALVE (MV1) permits pump maintenance without draining oil reservoir. CAUTION: DO NOT start engine with MV1 closed.

65 PSI Check VALVE (CV5) prevents excess pressure from damaging HEAT EXCHANGER (HE).

V. HYDRAULIC CIRCUITRY

HYDRAULIC SCHEMATIC

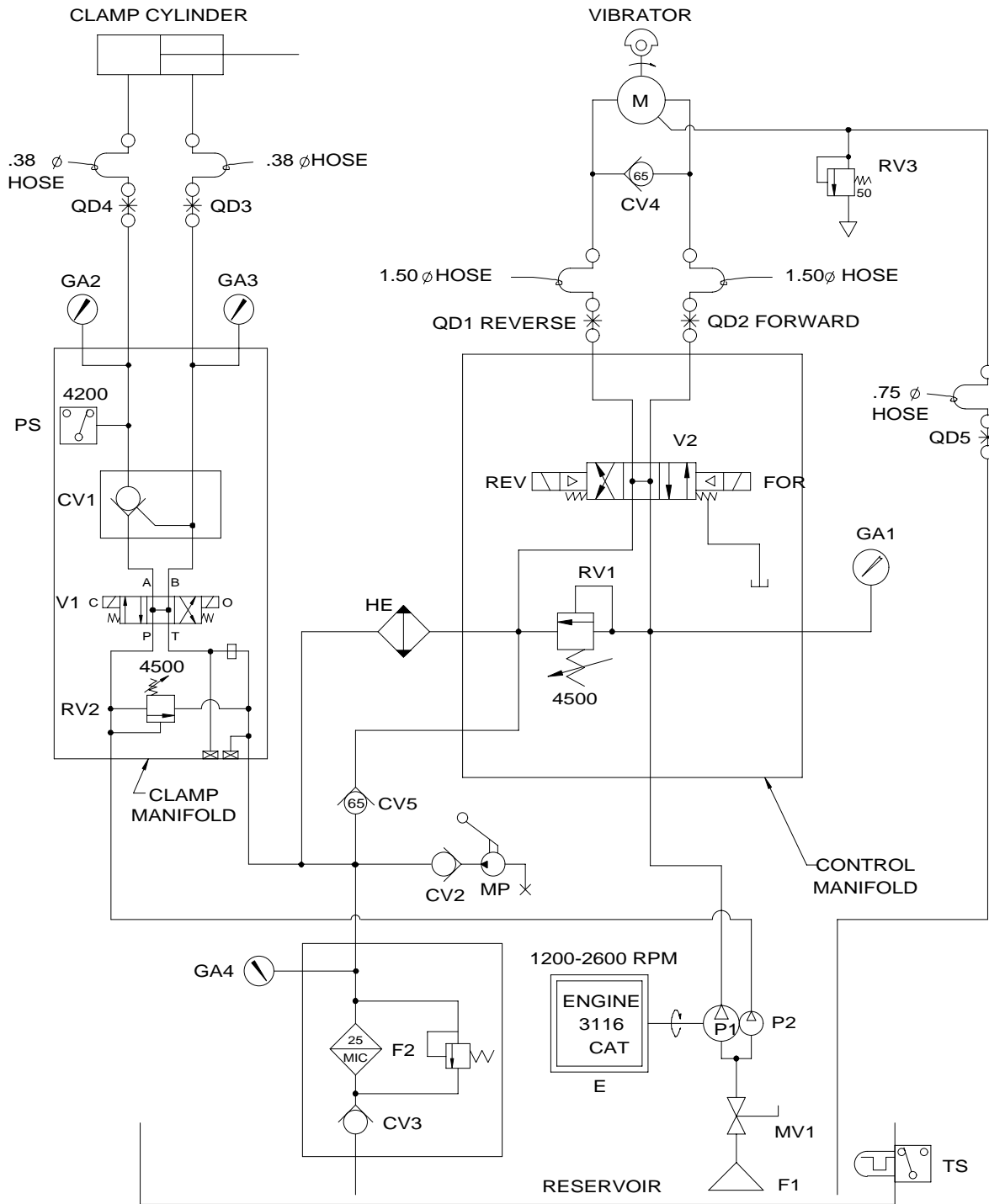

V. HYDRAULIC CIRCUITRY

F. HYDRAULIC COMPONENTS LIST

Notation	Description	Part Number	Page Ref.
CV1	Clamp Check Valve	110149	VIII-33
CV2	Manual Pump Check Valve	100451	VIII-25
CV4	Check Valve - Vibrator	810435	VIII-9
CV5	Bypass Check Valve	130339	VIII-31
CYL	Hydraulic Clamp Cylinder		
E	Diesel Engine	130739	VIII-24
F2	Return Filter (4)	100518	VIII-24
GA1	Forward Pressure Gage	110600	VIII-19
GA2	Close Clamp Pressure Gage	110600	VIII-19
GA3	Open Clamp Pressure Gage	110600	VIII-19
GA4	Filter Indicator Gage (2)	100436	VIII-27
HE	Heat Exchanger	400099	VIII-24
M	Motor	130025	VIII-11
MP	Manual Pump	100447	VIII-25
P1	Drive Pump	170309	VIII-24
P2	Clamp Pump	170939	VIII-???
PS-1	Clamp Pressure Switch	810033	VIII-33
QD1	Vibrator Reverse Disconnect	400093	VIII-24
QD2	Vibrator Forward Disconnect	400111	VIII-24
QD3	Clamp Open Disconnect	100777	VIII-26
QD4	Clamp Close Disconnect	100245	VIII-26
QD5	Case Drain Disconnect	400095	VIII-24
RV1	Relief Valve	400742	VIII-31
RV2	Clamp Relief Valve	100898	VIII-33
RV3	Case Drain Relief Valve	100032	VIII-7
TS	Temperature Switch	400115	VIII-26
V1	Clamp Control Valve	110147	VIII-33
V2	Control Valve	400786	VIII-31

VI. ELECTRIC CIRCUITRY (REFERENCE:ELECTRICAL SCHEMATIC PG VI-5)

A. STARTING DIESEL ENGINE

The engine batteries (EB1, EB2) provides 24-volt current to start the diesel engine. With the MAIN POWER (CB2) switch ON (the vibrator switch REV-FOR on the remote control pendant should be in the OFF position "neutral") and holding the SHUTDOWN RESET button in, turning the ENGINE START SWITCH to START will energize the start relay which energizes the STARTER MOTOR and turns over the diesel engine. If fuel is available, the diesel engine will start.

B. STOPPING DIESEL ENGINE

Turning the engine start switch to OFF de-energizes the fuel pump fuel solenoid which shuts off the fuel supply to the diesel engine. The engine stops.

C. SAFETY CONTROL SYSTEM

A system of safety controls shut off the fuel supply, which stops the diesel engine in the event that engine water temperature is too high or engine oil pressure is too low. The heart of the safety system is the shutdown reset, which is normally closed, thereby providing current to operate the HOUR METER (M1) and to energize the fuel solenoid. Energizing the fuel solenoid opens the injector pump and allows fuel to flow to the diesel engine. The shutdown reset must remain closed so that fuel continues to flow to the diesel engine.

If the coil in the shutdown reset is energized, the shutdown reset will open, shutting off the fuel to the diesel engine. The engine will stop. The coil may be energized by either of the following devices:

1. Engine Oil Pressure Gage - If oil pressure is below 15 PSI (1 Bar), the contacts of the gage will be closed providing current to energize the shutdown rest coil. During start-up, the button of the shutdown reset (on the control panel) must be held in until the oil pressure exceeds 30 PSI (2 Bar).
2. Engine Water Temperature Gage - If water temperature exceeds 210°F (99° C), the contacts of the gage will close energizing the shutdown reset coil.
3. Emergency Stop - When the diesel engine is running, pressing the EMERGENCY STOP BUTTON on remote control pendant energizes the coil on the shutdown reset. The shutdown reset opens and the engine and the vibrator are stopped.

VI. ELECTRICAL CIRCUITRY

D. CLOSING HYDRAULIC CLAMP

With the diesel engine running, turning the clamp switch (OPEN-CLOSE), on the control pendant to CLOSE energizes the close-clamp solenoid (CLOSE-SOL.). This operates the clamp control hydraulic valve and closes the clamp.

When the pressure in the close-clamp hydraulic circuit reaches 4400 PSI (303 Bar), the pressure switch (PS-1) opens and de-energizes the CLOSE-CLAMP solenoid and turns on the CLAMP LIGHTS on the control pendant and control panel. If close-clamp pressure falls below 4100 PSI (283 Bar), the pressure switch closes and re-energizes the close-clamp solenoid to rebuild pressure. The clamp lights go out. When pressure returns to 4400 PSI (303 Bar), The pressure switch opens de-energizing the close-clamp solenoid and turns on the CLAMP LIGHTS.

E. OPENING HYDRAULIC CLAMP

With the diesel engine running, turning the clamp switch (OPEN-CLOSE) to OPEN energizes the open-clamp solenoid (OPEN SOL.). The clamp opens.

F. STARTING THE VIBRATOR

With the diesel engine running, turning the vibrator switch on the control pendant to the FORWARD position energizes the forward solenoid on the control valve (V2A). The control valve directs hydraulic oil to the hydraulic motors and the vibrator starts.

G. STOPPING THE VIBRATOR

With the diesel engine running, turning the vibrator switch on the control pendant to REVERSE energizes the reverse solenoid (V2B). Turning the vibrator switch to the OFF position de-energizes the control valve (V2). This stops the flow of hydraulic oil to the motor, and the vibrator stops.

VI. ELECTRICAL CIRCUITRY

H. OTHER

The AMMETER (AM) indicates charging amperes. The tachometer generator (TACH SENDER) powers the TACHOMETER (TACH) to indicate engine speed. The hour meter (M1) indicates the engine operating hours. With the main power switch ON, the TEMPERATURE SWITCH turns on the HYDRAULIC FLUID COLD LIGHT if the temperature of the hydraulic oil in the reservoir is below 70°F (21°C). At 70°F (21°C) or above, the temperature switch turns off the hydraulic fluid cold light.

Duplicate vibrator and clamp switches are located on the control pendant and on the control panel. Turning the LOCAL-REMOTE switch to LOCAL activates only the clamp and vibrator switches located on the control panel. Turning the LOCAL-REMOTE switch to REMOTE only permits operation of the clamp and vibrator from the control pendant. The emergency stop button on the pendant is functional at all times.

Turning the Throttle switch to the FAST position will retract the electric throttle actuator (M) and increase engine speed (RPM). Turning the Throttle switch to the SLOW position will extend the electric throttle actuator (M) and decrease engine speed.

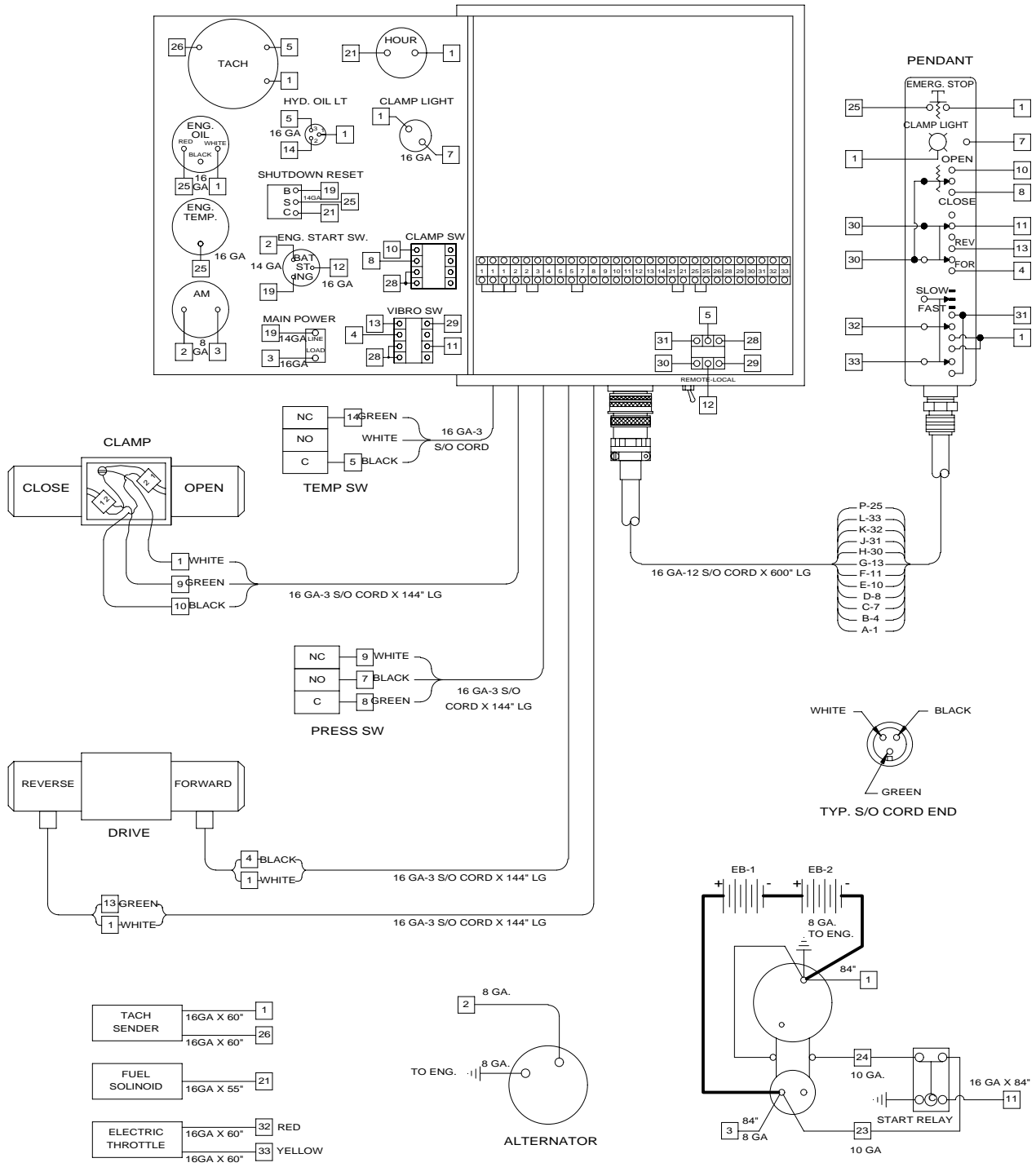

VI. ELECTRICAL CIRCUITRY

ELECTRICAL LAYOUT

VI. ELECTRICAL CIRCUITRY

ELECTRICAL SCHEMATIC

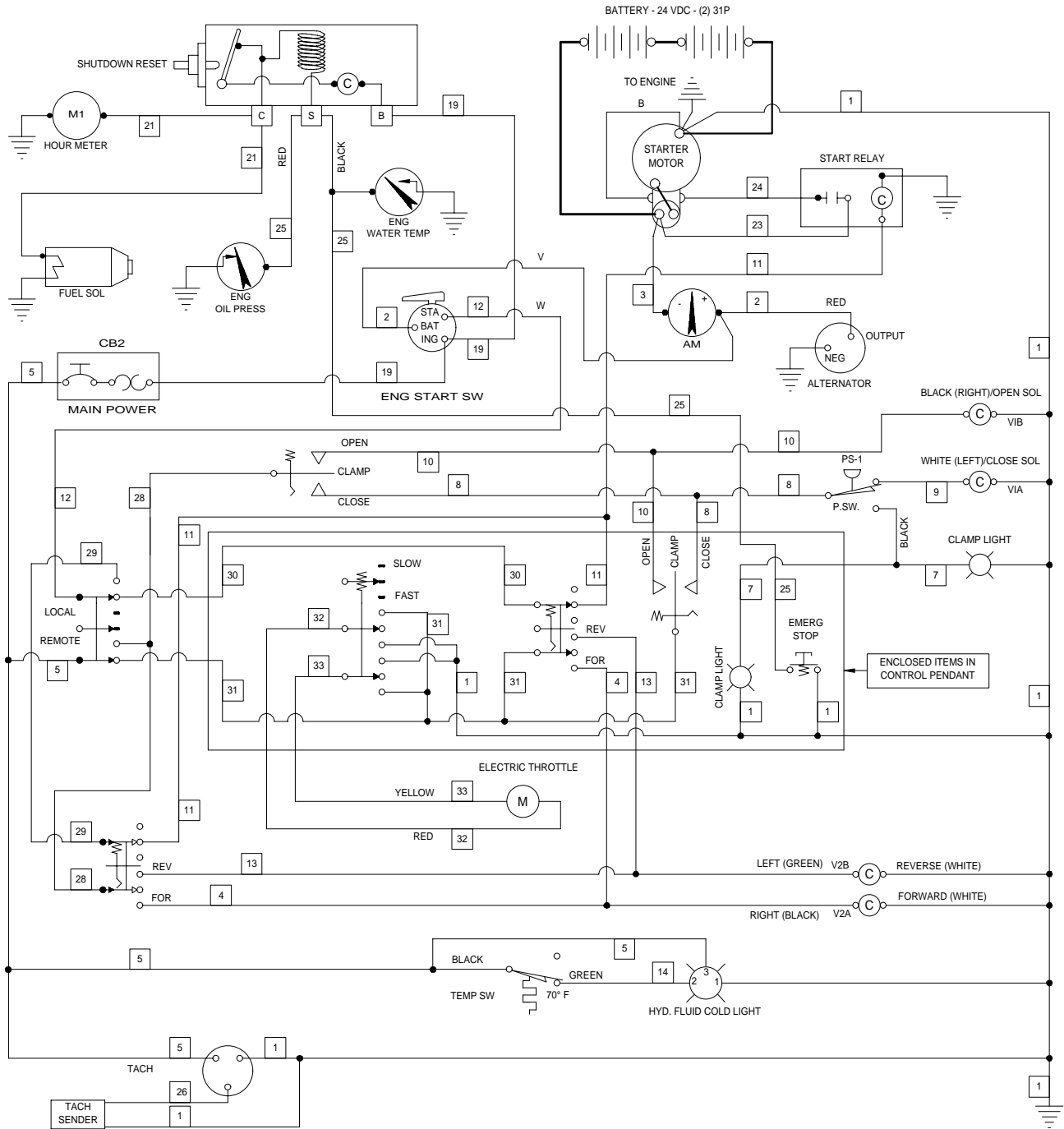

VI. ELECTRICAL CIRCUITRY

J. ELECTRICAL COMPONENTS LIST

Notation	Reference	Part Number	Page Ref.
ALTERNATOR	Alternator	See Cat. Parts Book	
AM	Ammeter	110371	VIII-17
BATTERY	24-Volt Battery	400890	VIII-24
CB2	Main Power Circuit Breaker	400141	VIII-17
CLAMP LIGHT (2)	Clamp Light	100359	VIII-17
ENG OIL PRESSURE	Oil Pressure Gage	100329	VIII-17
ENG. START SW	Engine Start Switch	130259	VIII-17
ENG WATER TEMP	Water Temperature Gage	130251	VIII-17
EMERG STOP	Emergency Stop Button	130507	VIII-21
FOR/REV (2)	Vibrator Switch (FWD/REV)	130155	VIII-17
FUEL SOL.	Fuel Solenoid Valve	See Cat. Parts Book	
HYD FLUID COLD	Hyd.Oil Warning Light	100355	VIII-17
LOCAL-REMOTE	Local-Remote Switch	140361	VIII-19
M	Electric Throttle	110246	VIII-27
M1	Hour Meter	100343	VIII-17
OPEN/CLOSE (2)	Clamp Switch (OPEN/CLOSE)	130155	VIII-17
PS-1	Pressure Switch	810033	VIII-33
SHUTDOWN RESET	Shutdown Reset	130257	VIII-17
SLOW-FAST	Engine Throttle Switch	100566	VIII-21
STARTER MOTOR	Engine Starter	See Cat.Parts Book	
START RELAY	Engine Start Relay Switch	See Cat.Parts Book	
TACH	Tachometer	130953	VIII-17
TACH SENDER	Tachometer Sender	130467	VIII-29
TS	Temperature Switch	400115	VIII-26
V1A	Close-Clamp Solenoid (Valve)	110147	VIII-33
V1B	Open-Clamp Solenoid (Valve)	110147	VIII-33
V2A	Forward Solenoid (Valve)	400786	VIII-31
V2B	Reverse Solenoid (Valve)	400786	VIII-31

VII. GENERAL DATA

A. ABBREVIATIONS

The abbreviations shown below are used throughout the parts lists and various other parts of the manual.

ASM.	Assembly
BHCS	Button Head Cap Screw
Cyl.	Cylinder
DC	Direct Current
FHCS	Flat Head Cap Screw
FLCS	Flanged Head Cap Screw
HC	High Collar
HHCS	Hex Head Cap Screw
HHPP	Hex Head Pipe Plug
HSSS	Hex Socket Set Screw
Hyd.	Hydraulic
Lg.	Long
mm	Millimeter
Mtg.	Mounting
NPT.	National Pipe Thread
PHMS	Phillips Head Machine Screw
P/N	Part Number
Qty.	Quantity
RHMS	Round Head Machine Screw
Sch.	Schedule
SHCS	Socket Head Cap Screw
SHPP	Socket Head Pipe Plug
SHSS	Socket Head Shoulder Screw
S/N	Serial Number
Sol.	Solenoid

B. SCREWS AND BOLTS

1. Practically all connections on the unit are made with socket head (Allen) cap screws. These high-strength screws are available at most industrial supply houses.
2. Screws and bolts are designated in the PARTS LIST in abbreviated form. (Refer to sub-section A, above, for specific abbreviations.) Listed below is a typical screw description:

.5 - 13 UNC x 1.50 LG SHCS	.5 = Diameter
	13 UNC = Threads Per Inch
	1.50 LG = Length
	SHCS = Screw Type Abbreviation
3. Some screws or bolts require a specific torque when replacing. For identification of these bolts and a more thorough understanding of torque, refer to Page VII-47.

VII. GENERAL DATA

C. SERIAL NUMBER LOCATIONS

1. The following J&M vibratory units are serial numbered separately:
 - a. Vibrator
 - b. Power unit
2. In addition to the serial number plate itself (on vibrators and power units), the serial number is stamped into each unit in one or more places as follows:
 - a. Vibrator stamped twice - once on top right side of suppressor housing, once on bottom lip of vibration case on right side of motors' side.
 - b. Power unit stamped twice - once on control panel side of unit at right corner of reservoir, once on sub-base inside door below hex-key rack.

VIII. ORDERING PARTS

A. PROCEDURE

1. When ordering parts, be sure to include the model and serial number of the unit or component. The serial number may be located by referring to SECTION VII, SERIAL NUMBER LOCATION. Confirm all telephone orders, in writing immediately to avoid duplicating shipment.
2. ORIGINAL EQUIPMENT; Where component serial numbers are given, these apply only to equipment and components originally furnished with the unit. Where equipment has been changed or upgraded these numbers may not be an adequate description.
3. SHIPMENT; State to whom shipment is to be made and method of shipment desired, otherwise our own judgment will be used.
4. SHORTAGES; Claims for shortages or errors should be made immediately upon receipt of parts. No responsibility will be assumed for delay, damage or loss of material while in transit. Broken, damaged or lost material should be refused or a full description made of damage or loss to the carrier agent on the freight or express bill.
5. RETURN OF PARTS; If for any reason you desire to return parts to the factory or to any distributor from whom these parts were obtained, you must first secure permission to return the parts. Shipping instructions will be given along with this permission. A ten percent handling charge must be assessed against the returned shipment unless an error is made by the factory or by the distributor when filling your order.

VIII. ORDERING PARTS

FITT	2	L	-	16	M	12	J	00	0	-	00L	0	0	0	1
SELECTOR INDEX											MATERIAL				
2 - INCH FITTING											1 - CARBON STEEL				
9 - METRIC FITTING											2 - BRASS				
CONFIGURATION OR SHAPE OF FITTING											4 - STAINLESS STL				
S - STRAIGHT FITTING											5 - AAR MAL IRON				
L - 90 Deg. ELBOW											6 - MALEABLE IRON				
V - 45 Deg. ELBOW											8 - FORGED STEEL				
T - TEE											SPECIAL NOTATIONS				
C - CAP											PRESSURE RATING				
P - PLUG											0 - NONE				
U - UNION											1 - 125 LB.				
X - CROSS											3 - SCH 40				
(FOURTH END FITT'G REQ'D.)											4 - SCH 80				
FIRST END SIZE											INSTALLATION AID OR STYLE OF HEAD				
* IN 1/16THS OF AN INCH											0 - NOT APPLICABLE				
(INDEX 2)											H - REGULAR HEX				
IN MILLIMETERS (INDEX 9)											Q - SQUARE HEAD (EXT.)				
SEE GENERAL SPECIFICATION SHEET FOR SEQUENCE OF ORDER											R - SQUARE HEAD (INT.)				
FIRST END FITTING STYLE											S - HEX HEAD (INT SOCKET)				
SEE FITTING STYLE SELECTOR CHART SC-1											T - HEX HEAD (EXT.)				
SECOND END SIZE											LENGTH CODE				
IF APPLICABLE - SEE FIRST END SIZE											(ELBOWS & NIPPLES)				
SECOND END FITTING STYLE											__L - LONG (ELBOW)				
IF APPLICABLE - SEE FIRST END FITTING STYLE											__X - EXTRA LONG (ELBOW)				
THIRD END SIZE											__C - CLOSE (NIPPLE)				
IF APPLICABLE - SEE FIRST END SIZE											PIPE NIPPLES (LONG) ONLY				
THIRD END FITTING STYLE											IN DEC. INCHES FOR INDEX 2				
IF APPLICABLE - SEE FIRST END SIZE											050 = 5.0 INCHES				
											105 = 10.5 INCHES				
											IN MILLIMETERS FOR INDEX 9				
											120 = 12.0 MILLIMETERS				
											084 = 8.4 MILLIMETERS				
											FOURTH END SIZE & FITTING STYLE				
											(CROSSES ONLY)				
											SEE FIRST END FITTING SIZE OR END STYLE				
* EXCEPTIONS															
90 = 10"				96 = 6"											
92 = 12"				98 = 8"											
94 = 14"				99 = NON CODE SIZE											

B. FITTING DESCRIPTION KEY

VIII. ORDERING PARTS

B. FITTING DESCRIPTION KEY (CONTINUED)

FITTING STYLE SELECTOR CHART

SC-1

FOR END FITTING STYLE SELECTION

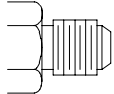
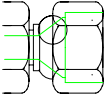
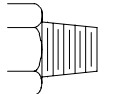
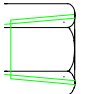
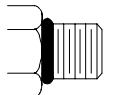
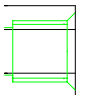
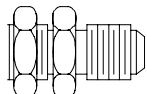
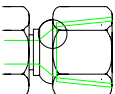
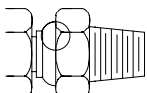
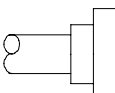
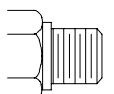
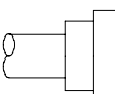
M		JIC MALE 37 Deg. FLARE	J		JIC FEMALE 37 Deg. FLARE (& SWIVEL)
P		MALE PIPE NPT	Q		FEMALE PIPE NPTF
R		S.A.E. MALE O-RING (& ADJUSTABLE)	K		S.A.E. FEMALE O-RING
B		JIC MALE 37 Deg. FLARE BULKHEAD	N		FEMALE PIPE NPSM-SWIVEL
D		MALE PIPE NPT SWIVEL	F		SPLIT FLANGE 3000 PSI. CODE 61
S		B.S.P. MALE PIPE	H		SPLIT FLANGE 6000 PSI. CODE 62

VIII. ORDERING PARTS

C. HOSE DESCRIPTION CODE

The HOSE DESCRIPTION CODE is a 24 digit number enabling easier and quicker identification whenever a hose replacement is desired. The key below explains the structure of the coded number in detail.

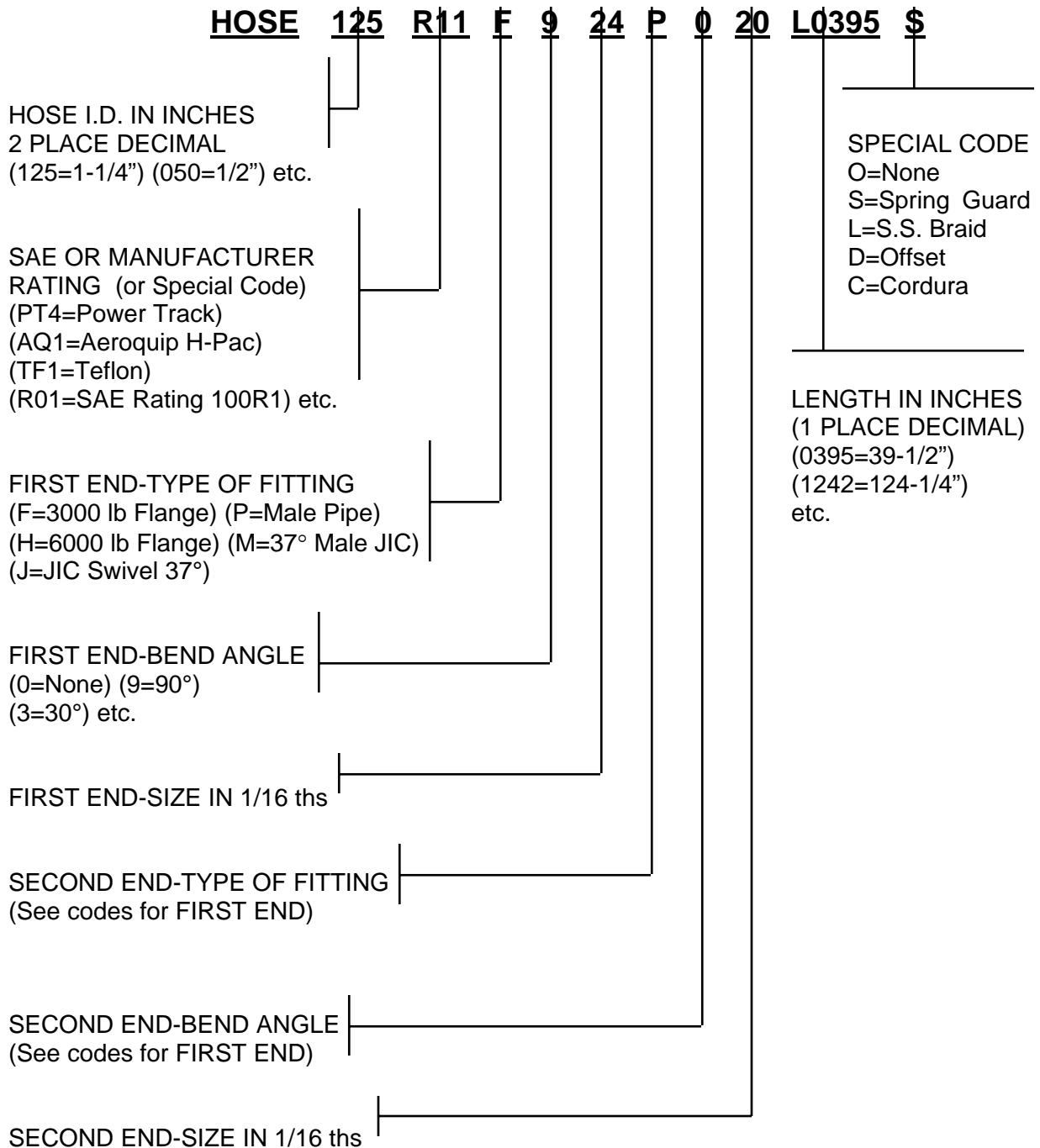

VIII. ORDERING PARTS

D. PARTS IDENTIFICATION

1. Parts lists and drawings are included on the following pages for the equipment components shown below:

a. VIBRATION SUPPRESSOR	175027
b. VIBRATION CASE	173005
c. HOSE ASSEMBLIES -INTERCONNECTING	175047
d. POWER UNIT - ENCLOSURE	800379
e. POWER UNIT - INTERNAL	175003
f. CONTROL BOX	173011
g. CONTROL MANIFOLD ASSEMBLY	173013
h. CLAMP MANIFOLD	810035
i. 216 CLAMP CYLINDER	810217

2. The spare parts list SECTION VIII - RECOMMENDED SPARE PARTS contains spare parts which may be very useful in keeping down-time to a minimum, especially in remote or secluded job sites where unforeseen communication problems could cause delay of the delivery of an awaited part.

These RECOMMENDED SPARE PARTS may be ordered beforehand, individually or as a package group as shown in the PARTS LIST.

VIII. ORDERING PARTS

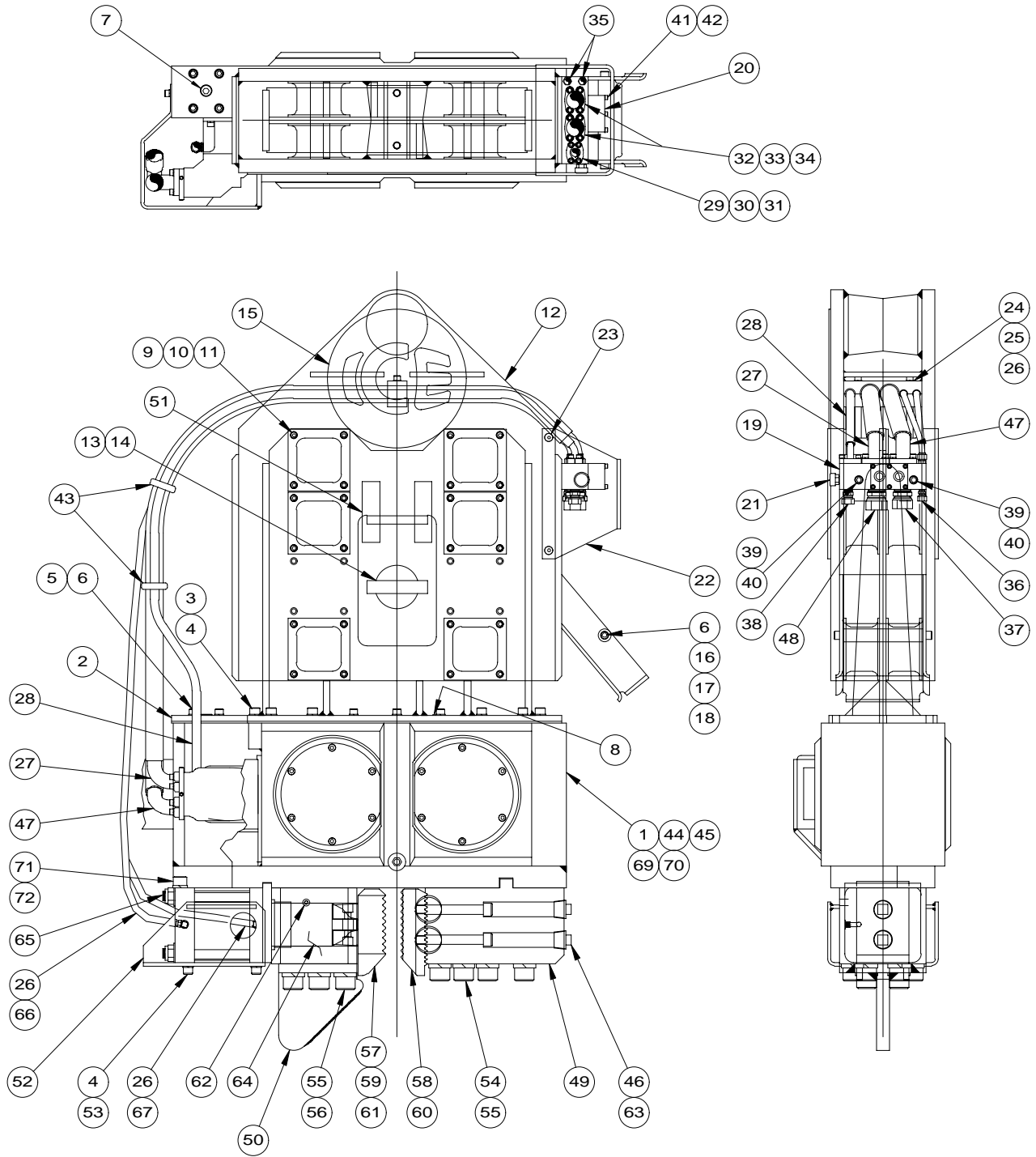

VIBRATION SUPPRESSOR

175027

VIBRATION SUPPRESSOR

175027

Item	Part Number	Qty.	Description
1	173005	1	Transmission Case Asm
2	130487	1	223 Transmission Adapter
3	100067	15	.75-10 X 2.5 Lg Shcs Loc Wel
4	100069	19	.75 Lock Washer Medium
5	100071	10	.625-11 X 2.5 Lg Shcs Loc Wel
6	100007	12	.625 Lock Washer Medium
7	100063	1	FITT2P-16P000000-000S007
8	100423	1	FITT2P-08P000000-000S007
9	130023	12	Elastomer
10	100011	72	.5-13 X 2.0 Lg SHCS
11	130049	72	.5-13 Esna Nut
12	130045	1	Suppressor Housing
13	130015	1	Stop Pin
14	110715	14	1.5 X .25 Bar Per In
15	400277	1	I C E Logo Plate
16	130297	1	Hose Guide
17	130299	1	Hose Guide Rod
18	100575	2	.625-11 X 1.25 Lg SHCS
19	130115	1	Terminal Manifold
20	810435	1	216 Check Valve Assembly
21	100032	1	Relief Valve
22	130239	1	Coupler Guard
23	100021	4	.5-13 X 1.5 FHCS
24	130121	1	HOSE CLAMP
25	110735	2	.5-13 X 2.5 Lg SHCS
26	130057	2	FITT2L-06M06R000-000H001
27	130495	1	HOSE125R10F420H916L08900
28	130171	1	HOSE075R01F412P008L0910S
29	100049	2	#12 Split Flange Half
30	100143	4	.375-16 X 1.25 Lg SHCS Loc Wel
31	100097	1	2-214 O-Ring 70 Duro
32	100045	4	#20 Pa Split Flange Half
33	100851	8	.438-14 X 1.25 Lg SHCS
34	100037	2	2-222 O-Ring 90 Duro
35	100053	2	6 O-Ring X 6 JIC Conn
36	100041	2	FITT2S-06PO6N000-000H001
37	100039	1	FITT2S-20P20N000-000H001
38	100043	2	FITT2S-12P12N000-000H001
39	130135	2	.625-11 X 3.5 Lg SHCS
40	130261	2	.625 Lock Washer H C

VIBRATION SUPPRESSOR (Continued)

175027

Item	Part Number	Qty.	Description
41	110177	6	.312-18 X 2.5 Lg SHCS
42	100287	6	.312 Lock Washer
43	130243	2	Rubber Tie Down
44	100298	2	Paint / Gal
45	100299	2	Primer / Gal
46	130733	2	FITT2P-24P000000-000Q001
47	130497	1	HOSE125R10F420H916L09200
48	100913	1	FITT2S-24N20P000-000H001
49	170297	1	Fixed Jaw Bracket
50	170361	1	Pile Feed Guide
51	110629	2	1 Logo Plate
52	130009	1	Cylinder Guard
53	400275	4	.75-10 X 1.5 Lg SHCS
54	130077	8	1.5-6 X 11 LG SHCS
55	100195	14	1.5 Lock Washer Extra Heavy
56	130293	6	1.5-6 X 12 Lg SHCS
57	810535	1	6" 216 Ds Movable Jaw
58	130469	1	6" Fixed Jaw
59	810433	1	216 Universal Movable Jaw
60	110515	1	Universal Fixed Jaw-Ser.
61	130449	1	Roll Pin .75 X 3"
62	100229	1	Grease Fitting
63	300043	2	1.0-8 X 8.0 Lg SHCS
64	130001	1	Guide Block
65	810217	1	216 Clamp Cylinder
66	130173	1	HOSE038R02J006J006L11000
67	130175	1	HOSE038R02J006J006L11500
69	170515	1	S/N Plate 11 Vibro
70	130381	4	Rivet
71	100209	1	1.00 Lock Washer Medium
72	100212	1	1.00-8 X 4.00 Lg SHCS Loc Wel

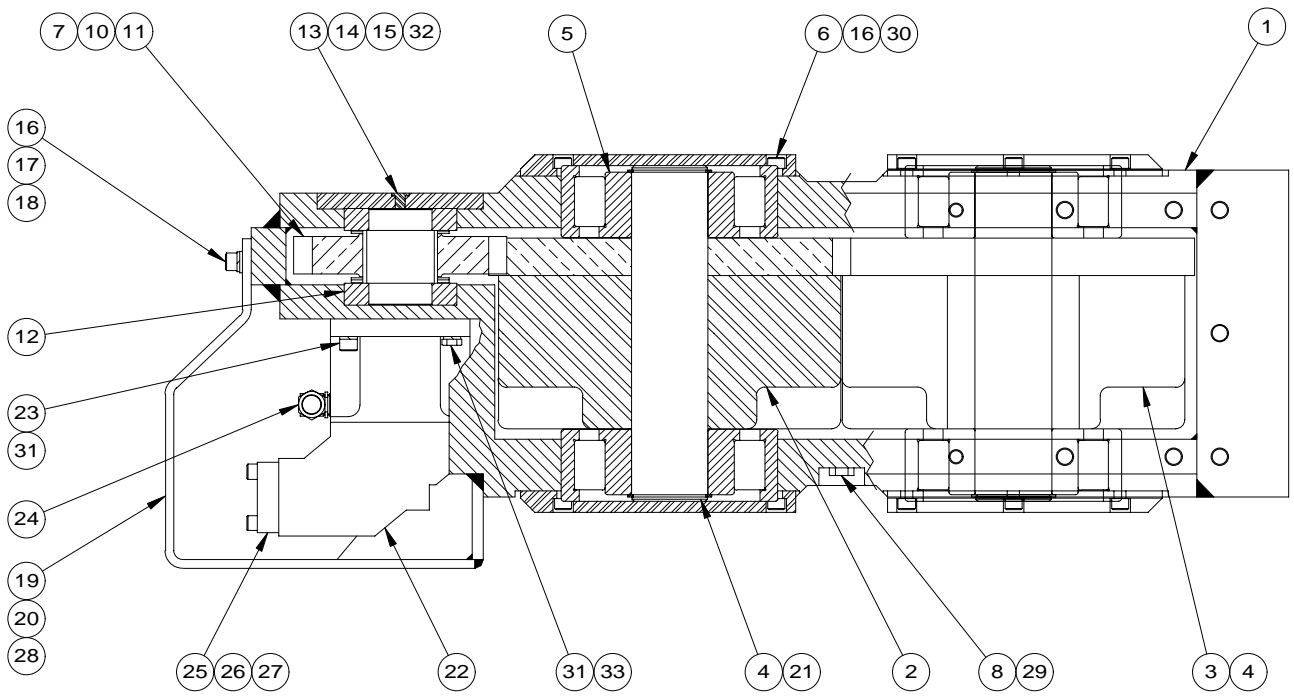

VIBRATION CASE

173005

Item	Part Number	Qty.	Description
1	173003	1	Transmission Case Frame
2	810437	1	416 Eccentric Gear Asm
3	810417	1	416 Eccentric Gear Asm
4	130481	2	Eccentric Shaft
5	130479	4	Roller Bearing
6	130485	4	Bearing Cover
7	130491	3	Snap Ring (3.50)
8	130605	1	Sight Gauge
9	100187	1	FITT2P-12P000000-000S0M7
10	130483	1	Pinion Shaft
11	110185	1	Motor Gear
12	110191	2	Motor Bearing
13	110855	1	Bearing Housing Cap
14	810229	1	Centrifugal Breather
15	110197	1	2-159 O-Ring
16	100119	31	.5-13 X 1.25 Lg SHCS Loc Wel
17	100121	7	.50 Lock Washer Medium
18	100483	4	.50 Flat Washer
19	100575	1	.625-11 X 1.25 Lg SHCS
20	100007	1	.625 Lock Washer Medium
21	100678	4	Snap Ring
22	130493	1	223 Motor
23	100163	3	.5-13 X 1.75 Lg SHCS Loc Wel
24	400071	1	FITT2L-10R08N000-000H001
25	100927	4	#16 Ph Split Flange Half
26	100125	8	.437-14 X 1.5 Lg SHCS Loc Wel
27	100091	2	2-219 O-Ring 70 Duro
28	130489	1	Motor Guard
29	110444	1/2	Transmission Oil / Gal.
30	100814	1	Sealant
31	100027	4	.5 Hi-Collar Lock Washer
32	100445	4	.5-13 X 1.0 Lg SHCS Loc Wel
33	100614	1	.5-13 UNC X 1.50 Lg HHCS

HOSE ASSEMBLIES - INTERCONNECTING

175047

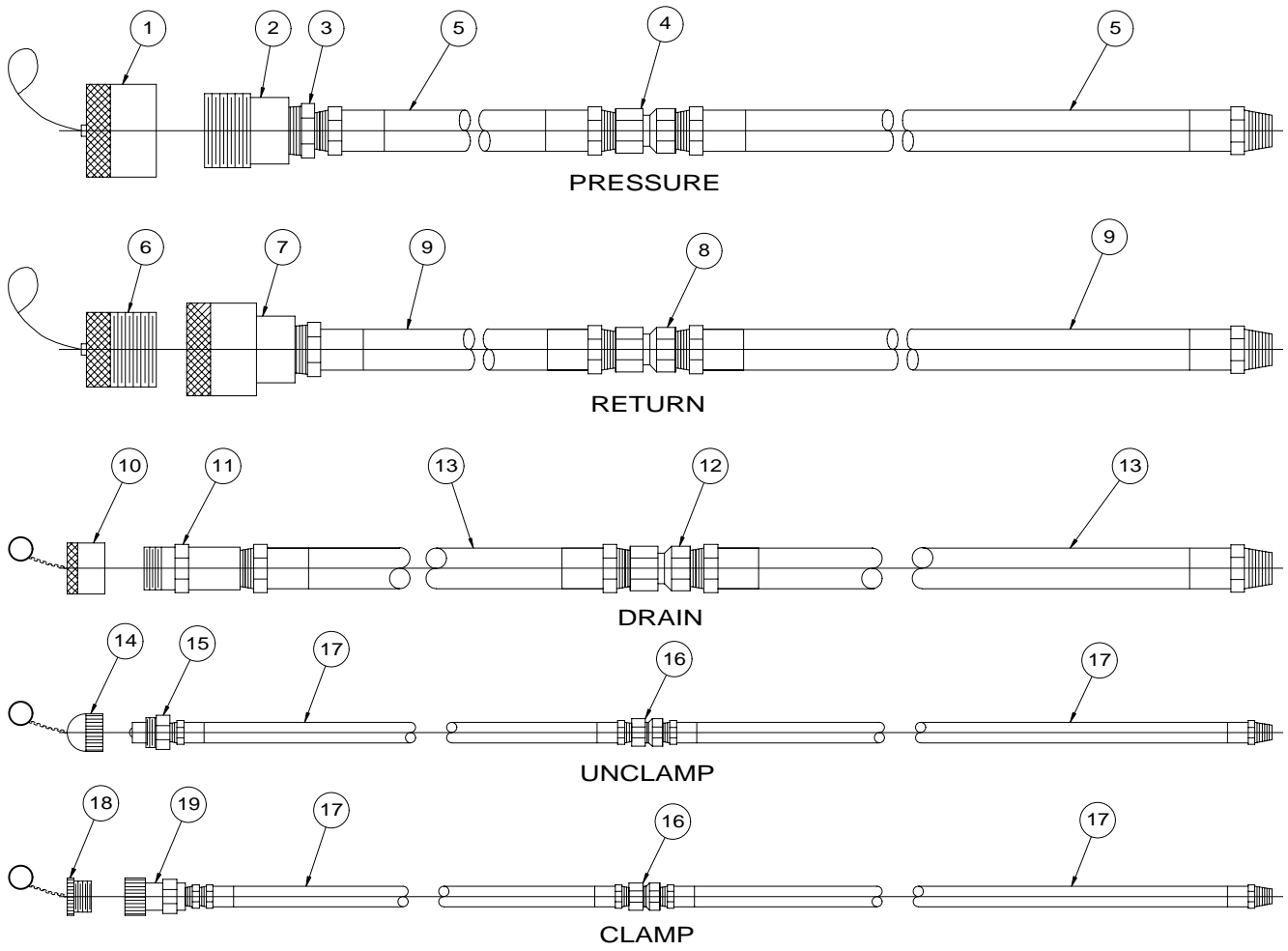

HOSE ASSEMBLIES - INTERCONNECTING

175047

Item	Part Number	Qty.	Description
1	110955	1	Dust Cap (1 - 1/2)
2	110690	1	Male Disconnect (1 - 1/2)
3	400159	1	FITT2S-24P20Q000-000H001
4	100235	1	FITT2S-20Q20N000-000H001
5	100233	2	HOSE125PT4P020P020L60000
6	110957	1	Dust Plug (1 - 1/2)
7	110692	1	Female Disconnect (1 - 1/2)
8	110139	1	FITT2S-24Q24N000-000H001
9	100911	2	HOSE150R02P024P024L60000
10	400253	1	Dust Cap (3/4)
11	400251	1	Male Disconnect (3/4)
12	100243	1	FITT2S-12Q12N000-000H001
13	100241	2	HOSE075R02P012P012L62000
14	100257	1	Dust Cap (3/8)
15	100245	1	Male Disconnect (3/8)
16	100249	2	FITT2S-06Q06N000-000H001
17	100247	4	HOSE038R02P006P006L62000
18	100737	1	Dust Plug (3/8)
19	100777	1	Female Disconnect (3/8)
20	130243	10	Rubber Tie Down

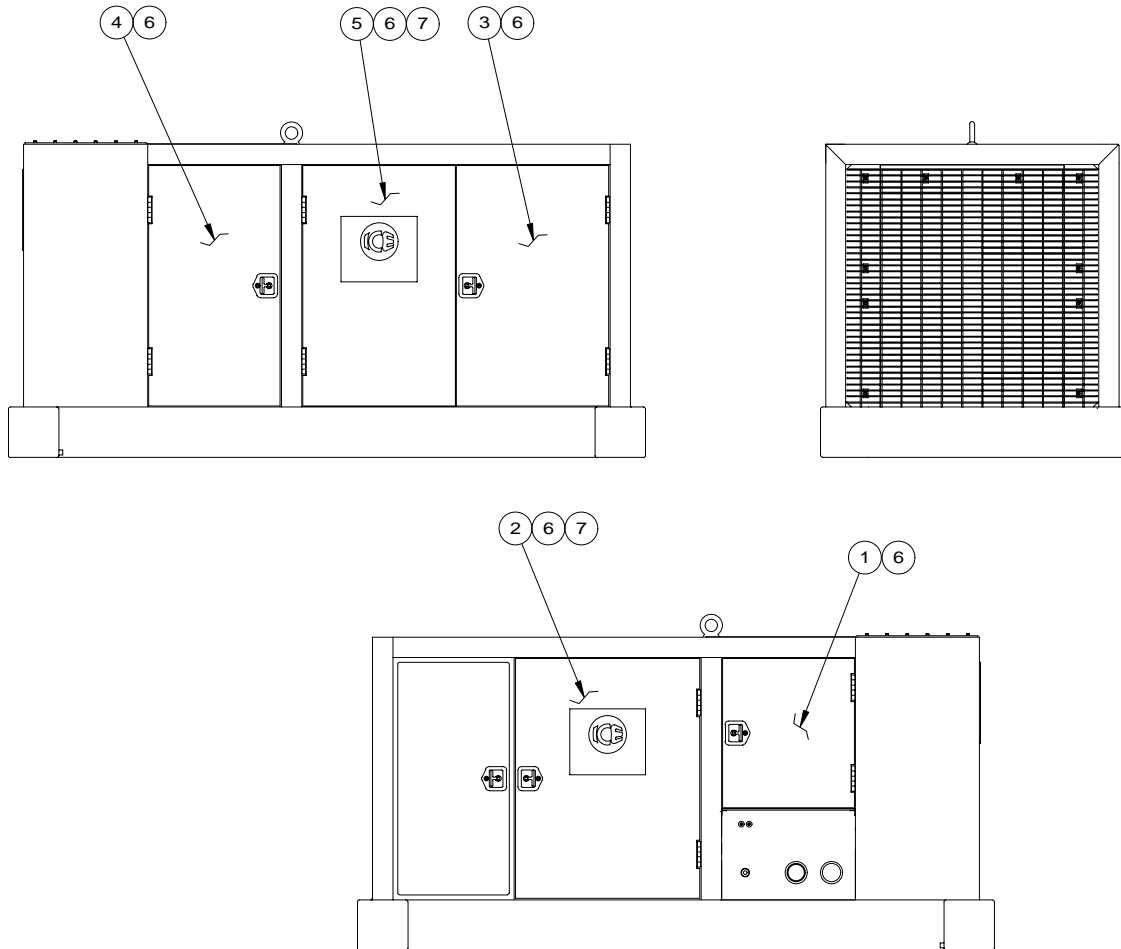

POWER UNIT ENCLOSURE - 325

800379

<u>Item</u>	<u>Part Number</u>	<u>Qty.</u>	<u>Description</u>
1	100550	1	Cover Door
2	100548	1	Cover Door
3	100546	1	Cover Door
4	100544	1	Cover Door
5	100542	1	Cover Door
6	100834	10	5" Door Hinge
7	100290	2	Decal

CONTROL BOX

173011

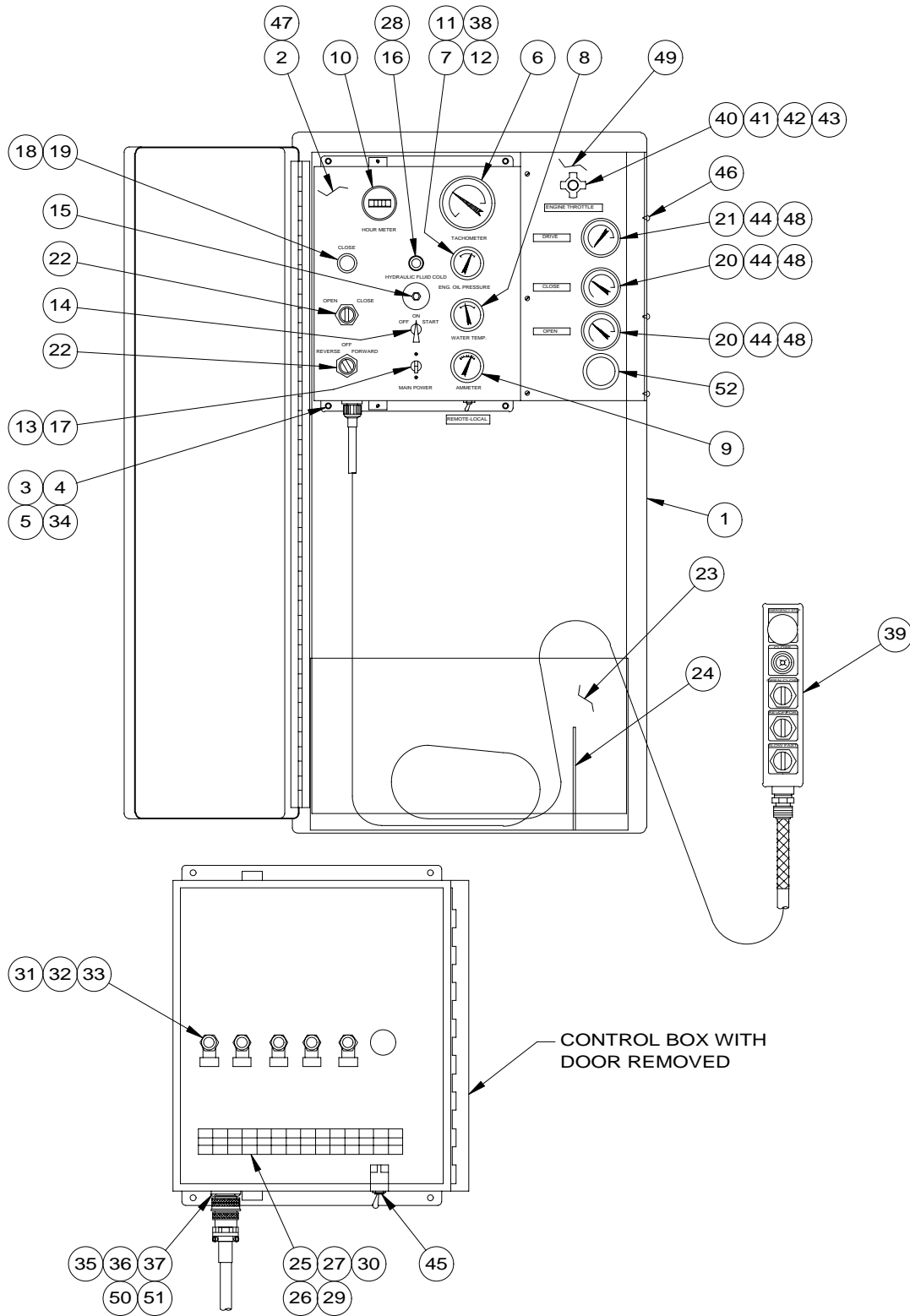

CONTROL BOX

173011

Item	Part Number	Qty.	Description
1	130151	1	Control Box Enclosure
2	100740	1	250 Control Box
3	100576	4	.25-20 X .625 Lg SHCS
4	100559	4	.25 Lock Washer
5	100598	4	.25-20 Hex Nut
6	130953	1	Tachometer Digital
7	100329	1	Oil Pressure Gauge
8	130251	1	Water Temp Gauge
9	110371	1	Ammeter
10	100343	1	Hourmeter
11	110415	5	.250 Oil Pressure Tube/Ft
12	100333	1	FITT2L-04E02Q000-000H002
13	400141	1	Circuit Breaker-10 A
14	130259	1	Start Switch
15	130257	1	Reset Button
16	100355	1	Dialight, Test
17	100331	2	#6-32 X .25 Lg BHCS
18	100359	1	Light, Pilot
19	100361	1	Lens, Clear-Pilot Lite
20	130205	2	HOSE019AQ1J004J004L09000
21	130207	1	HOSE019R01J004J004L10000
22	130155	2	Switch
23	130149	1	Box Panel
24	130387	1	Hose Bracket
25	400161	2	#10 Lock Washer
26	400163	2	#10-32 Hex Nut
27	110649	2	#10-32 X .375 Lg PHMS
28	130305	2	Warning Light Bulb (Bayonet)
29	110567	14	Terminal Block
30	110569	10	Terminal Mtg. Channel / In
31	100853	5	90 Deg S/O Comp Fitting
32	110841	5	.5 Plastic Bushing
33	110843	5	.5 Lock Nut
34	100597	4	.25 Flat Washer
35	110763	1	Female Amphenol Insert
36	100397	1	Amphenol Receptacle
37	110754	4	#6-32 X .375 Lg RHMS
38	300611	1	FITT2S-02P04E000-000H002
39	800393	1	175-325 Pendant Asm.
40	130255	1	Engine Throttle

CONTROL BOX

173011

<u>Item</u>	<u>Part Number</u>	<u>Qty.</u>	<u>Description</u>
41	100429	1	Throttle Cable Seal
42	100431	1	Throttle Cable Pivot
43	100577	1	Stop Cable Clamp
44	100321	3	FITT2L-04M04Q000-0000001
45	140361	1	Toggle Switch
46	100656	6	10-32 X .5 Lg PHMS-Self Tap
47	173001	1	230 Label Group
48	150079	3	2-1/2 Gauge 0-3000 PSI (GA1-3)
49	100738	1	Gage Panel
50	110696	4	#6 Lock Washer
51	110694	4	#6-32 Hex Nut
52	130463	1	2" Plug

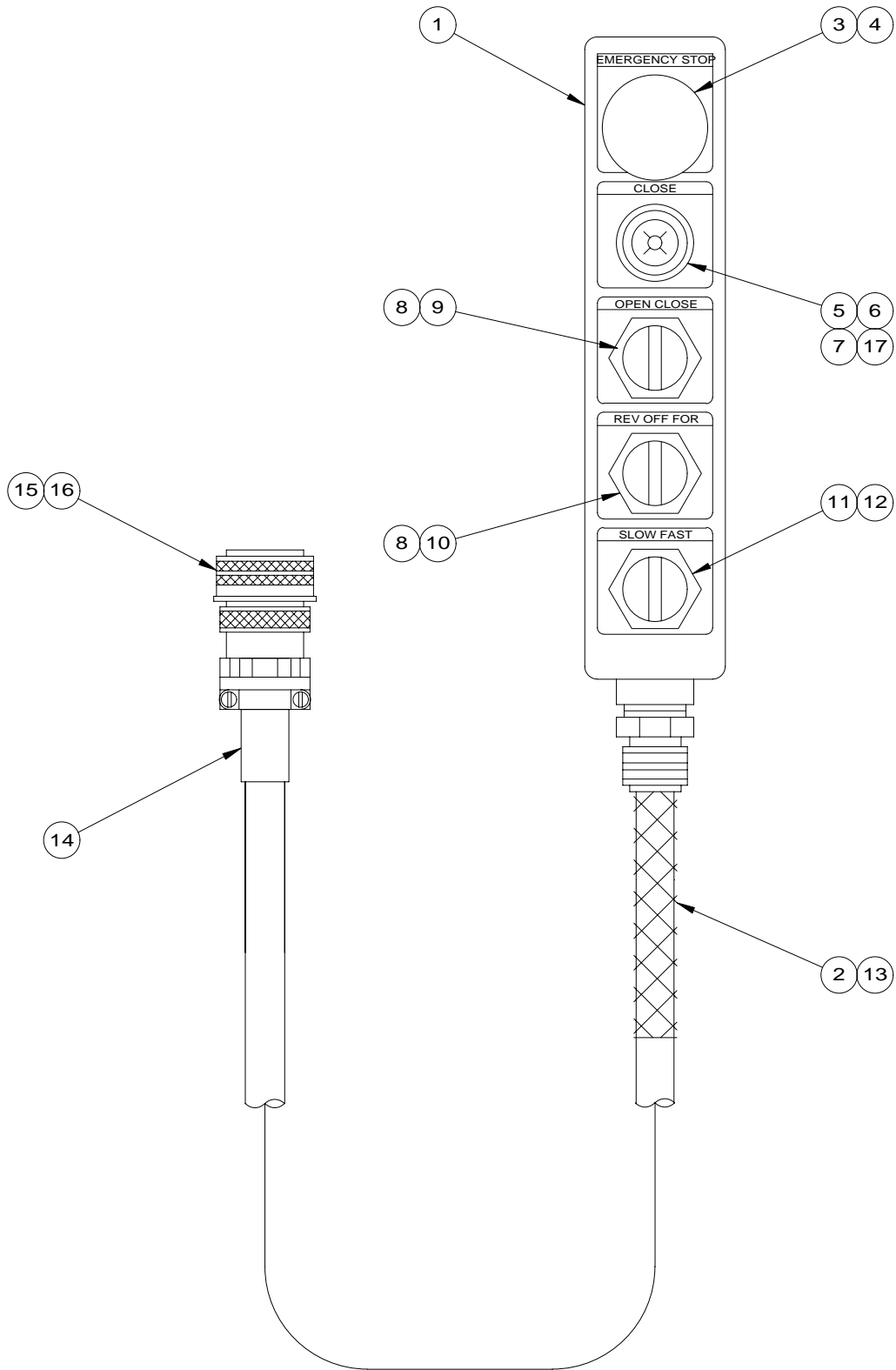

VIII-20 175-325 PENDANT ASSEMBLY 800393

Item	Part Number	Qty.	Description
1	130505	1	Pendant Box
2	110603	1	1.0 Strain Relief
3	130507	1	Emergency Stop Button
4	130509	1	Emergency Stop Label
5	100359	1	Light, Pilot
6	100361	1	Lens, Clear-Pilot Lite
7	100403	1	Close Nameplate
8	130155	2	Switch
9	100401	1	Open/Close Nameplate
10	100864	1	Rev-Off-For Nameplate
11	100566	1	Switch
12	100562	1	Slow-Fast Nameplate
13	100560	50	Pendant Cable/Ft
14	100375	1	Strain Relief-Amphenol
15	110761	1	Male Amphenol Insert-Plug
16	100395	1	Amphenol Plug
17	130307	1	Clamp Light Bulb

230 POWER UNIT - INTERNAL

175003

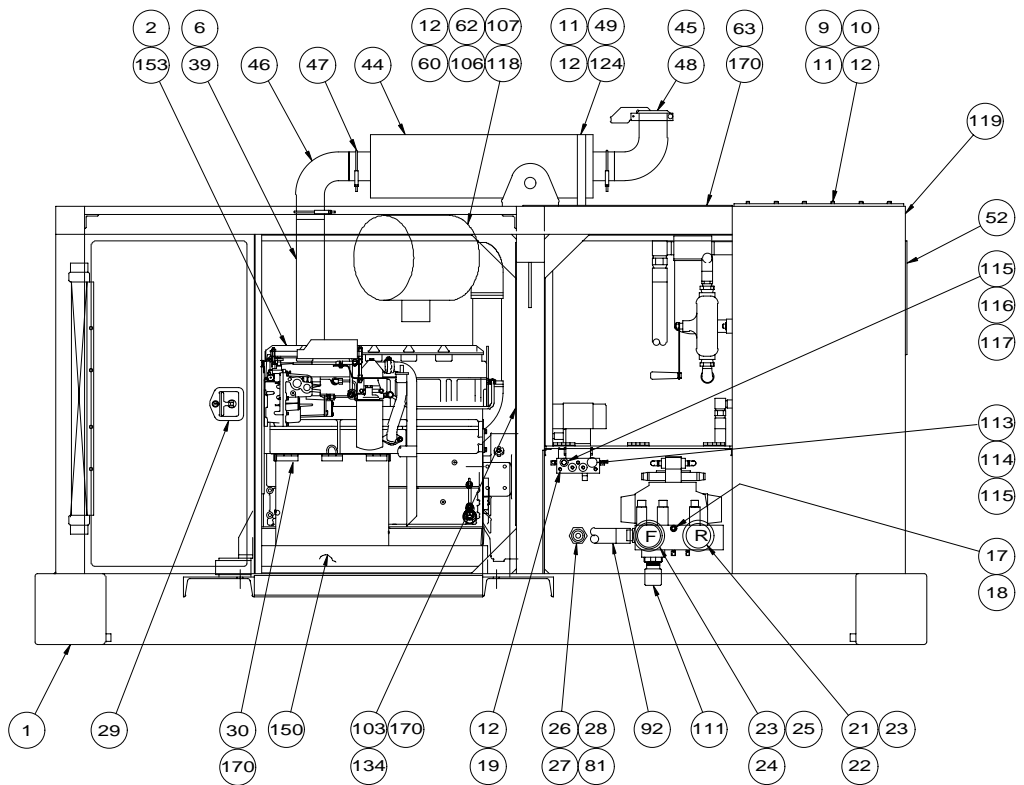
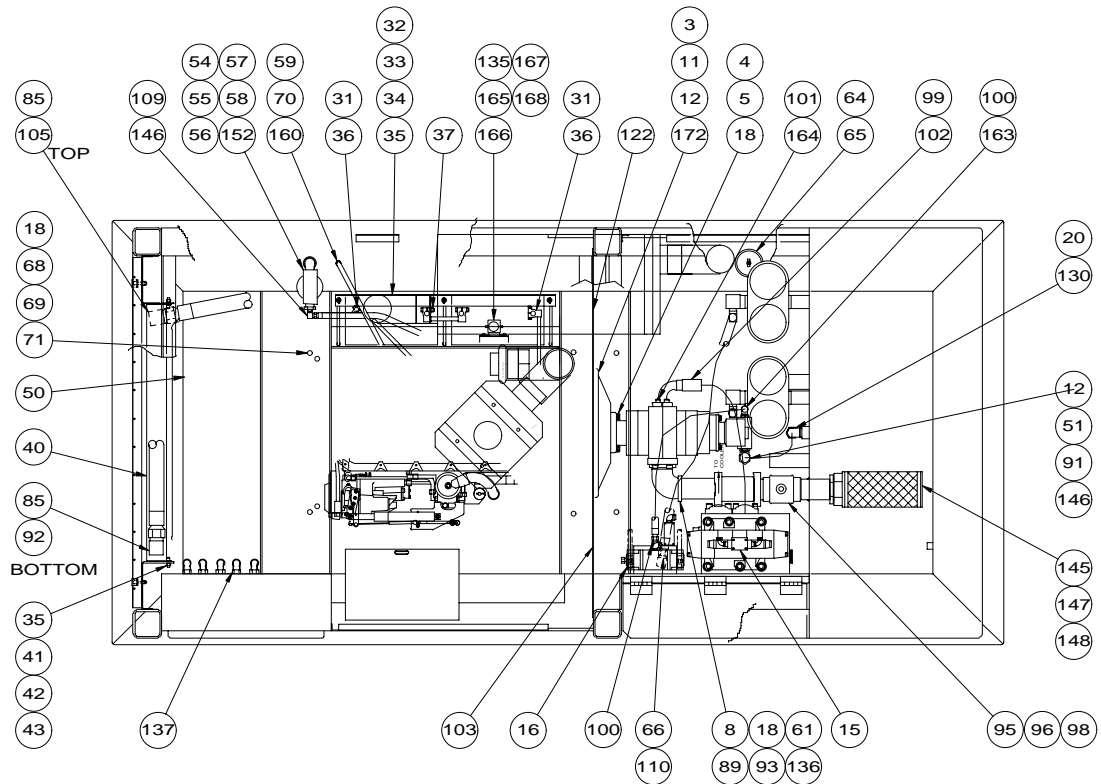

230 POWER UNIT - INTERNAL

175003

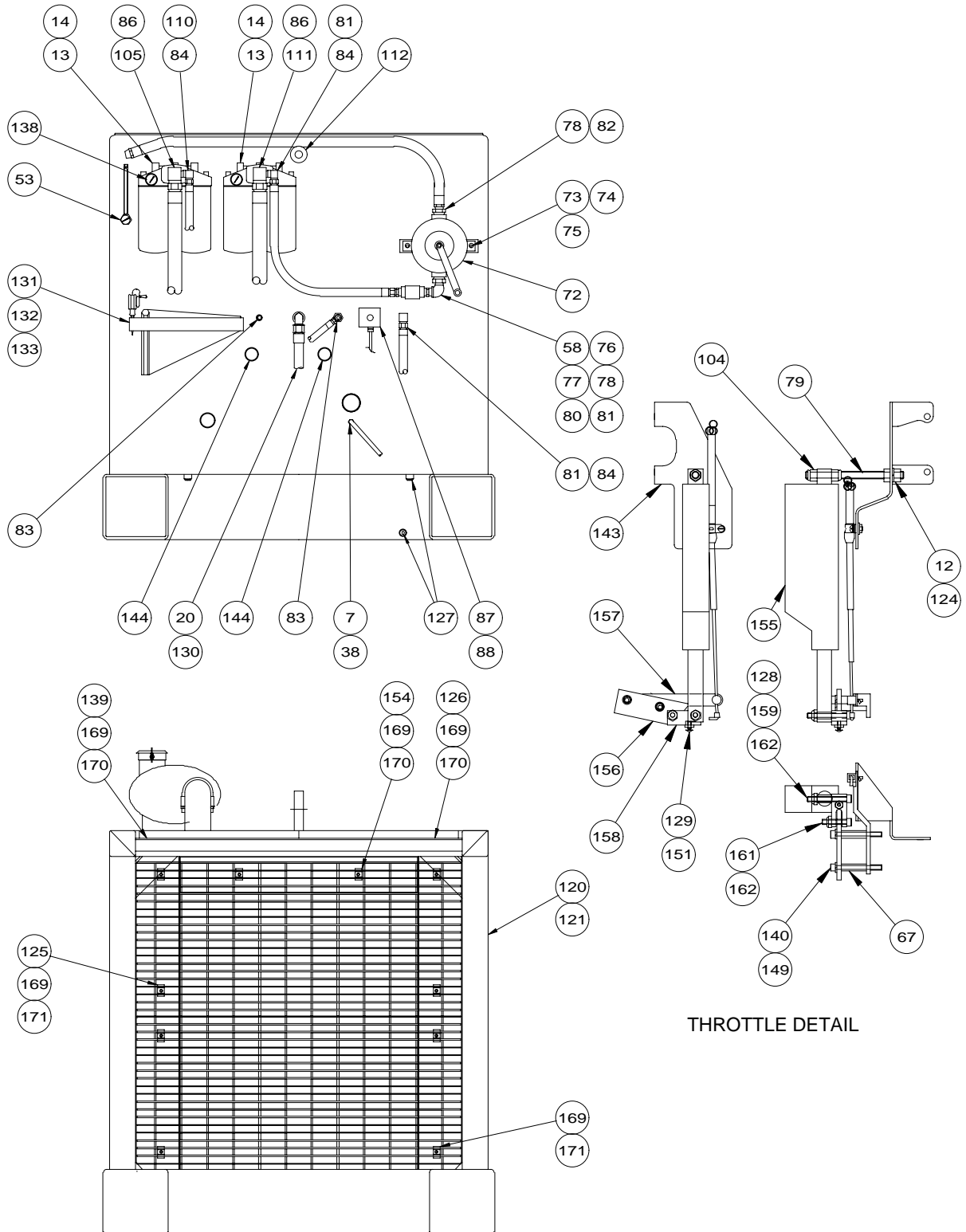

230 POWER UNIT - INTERNAL

175003

Item	Part Number	Qty.	Description
1	810563	1	175C / 325 Subbase Asm.
2	170239	1	Engine 3116 (220hp)
3	130743	1	Pump Adapter
4	170309	1	Pump
5	100614	4	.50-13 UNC X 1.50 Lg HHCS
6	100958	1	4 In Exhaust End
7	100149	1	HOSE025R02J004J004L01900
8	170311	1	-151 O-Ring
9	400129	1	Reservoir Cover
10	400225	1	Reservoir Gasket
11	100648	34	.375-16 X.875 Lg SHCS
12	400149	56	.375 Lock Washer
13	100520	2	Return Filter Asm.
14	100518	4	Return Filter Element
15	173013	1	230 Control Manifold Asm
16	810035	1	325 Clamp Manifold Assembly
17	100119	3	.5-13 X 1.25 Lg SHCS Loc Wel
18	100121	15	.50 Lock Washer Medium
19	100051	3	.375-16 X 1.0 Lg SHCS Loc Wel
20	120055	1	FITT2L-16M16P000-0000001
21	110690	1	1.50 Male Disconnect
22	110955	1	1.50 Dust Cap
23	110392	2	FITT2S-24R24P000-000H001
24	110692	1	1.50 Female Disconnect
25	110957	1	1.50 Dust Plug
26	400095	1	.75 Female Disconnect
27	400121	1	.75 Dust Plug
28	100387	1	FITT2S-12P12B000-000H001
29	173011	1	230 Control Box Asm
30	100558	1	Tool Box
31	400890	2	Battery
32	400888	1	Battery Holddown
33	400231	3	Hold Down Stud
34	100831	3	.312 Wing Nut
35	100293	19	.312 Flat Washer
36	100537	2	Battery Cable-24"
37	110653	1	Battery Cable-6
38	100145	1	FITT2L-04M04P000-0000001
39	130727	1	45 Deg Exhaust Elbow 4"
40	400099	1	Heat Exchanger

230 POWER UNIT - INTERNAL

175003

Item	Part Number	Qty.	Description
41	100105	8	.312-18 X 1.0 Lg SHCS Loc Wel
42	100287	8	.312 Lock Washer
43	100289	8	.312-18 Hex Nut
44	130745	1	Muffler
45	130749	1	Exhaust Elbow 4"
46	130751	1	Exhaust Outlet Elbow 4"
47	400919	5	4" U-Clamp
48	100890	1	Rain Cap
49	130747	1	Muffler Support
50	100726	5	Antifreeze/Gal
51	100700	2	.375-16 UNC X 1.25 HHCS
52	400277	1	Logo Plate
53	130179	1	Sight Gauge And Thermometer
54	120611	1	Water Separator Asm
55	120425	1	FITT2S-16P16P000-1200301
56	100715	1	FITT2S-16P06Q000-000H001
57	400227	1	FITT2L-06M06P000-0000001
58	110377	2	FITT2L-16P16Q000-0000306
59	100228	1	HOSE038R02J006J006L06100
60	130753	1	Air Cleaner Element
61	100011	4	.5-13 X 2.0 Lg SHCS
62	130237	6	Hose Clamp
63	100350	1	Unit Cover
64	100417	1	FITT2C-48Q000000-0000306
65	100419	1	Petcock
66	300231	1	FITT2V-12M12J000-000H001
67	130779	2	Tube .38OD .28ID X 1.25 Lg
68	110735	4	.5-13 X 2.5 Lg SHCS
69	100483	4	.50 Flat Washer
70	130057	1	FITT2L-06M06R000-000H001
71	100485	4	.5-13 Hex Nut
72	100447	1	Hand Pump
73	100439	2	.437-X1.75 Lg SHCS
74	400153	2	.437 Flat Washer
75	100443	2	.437 Lock Washer
76	100449	1	FITT2S-16P16P000-000H001
77	100451	1	Check Valve
78	110089	1	FITT2S-20P16Q000-000H001
79	130755	1	.38-16UNC All Thread 5.00 Lg
80	300119	1	FITT2S-16P12M000-000H001

230 POWER UNIT - INTERNAL

175003

Item	Part Number	Qty.	Description
81	130201	2	HOSE075R01J012J012L04000
82	400215	1	HOSE100R01P016P016L08400
83	100183	2	FITT2P-12P000000-000S007
84	100489	3	FITT2L-12M12P000-0000001
85	100588	2	FITT2L-24M24P000-0000001
86	810575	2	Special 90 Elbow
87	400115	1	Temperature Switch
88	110237	1	Str S/O Cord Adapter
89	130777	1	FITT2S-40P000000-0750001
90	130773	1	FITT2S-06R02Q000-000H001
91	170393	1	Clamp Pump
92	130515	1	HOSE150R02J024F924L10000
93	170349	1	Pick-Up Flange
94	100143	12	.375-16 X 1.25 Lg SHCS Loc Wel
95	130119	1	FITT2S-40P000000-0450301
96	130139	1	2.5 Flexible Coupling
97	130769	1	FITT2S-08R08Q000-000H001
98	400117	1	Stop Cock
99	170307	1	HOSE150PT4F024F920L03200
100	130613	1	HOSE050PT4J008J008L02500
101	100045	2	#20 Pa Split Flange Half
102	100037	1	2-222 O-Ring 90 Duro
103	100364	1	Left Fire Wall
104	100762	2	.375-16 UNC Esna Nut
105	110586	1	HOSE150R01JO24J024L12900
106	100968	2	Intake Elbow
107	130771	20	4" O.D. Tube X 16 Ga / Inch
108	400411	1	FITT2L-06M06J000-000H001
109	170241	1	HOSE038R01J006J006L07000
110	100484	1	HOSE075R01J012J012L08400
111	100482	1	HOSE150R02J024J024L07200
112	100455	1	Breather
113	100777	1	.375 Female Disconnect
114	100737	1	.375 Dust Plug
115	110794	2	FITT2S-06P06P000-000H001
116	100245	1	.375 Male Disconnect
117	100257	1	.375 Dust Cap
118	130117	2	.375 X1.5 Lg SHCS
119	140415	275	Hydraulic Fluid/Gal
120	100299	3	Primer/Gal

230 POWER UNIT - INTERNAL

175003

Item	Part Number	Qty.	Description
121	100298	3	I C E Green Paint / Gal
122	100362	1	Right Fire Wall
123	100053	1	6 O-Ring X 6 JIC Conn
124	100535	4	.375 -16 Hex Nut
125	100404	2	Intake Grill (300)
126	100400	1	Left Exhaust Grill
127	100423	4	FITT2P-08P000000-000S007
128	110244	1	Tube .38OD .28 ID X .88 Lg
129	110827	1	10-32 X .75 BHCS S.S.
130	100862	1	HOSE100R01J016J016L03300
131	810045	1	Hex Key Group
132	100651	1	24 V Test Light
133	100600	1	Hex Key Rack
134	100597	4	.25 Flat Washer
135	100504	1	24v Solenoid
136	100962	1	FITT2L-40P40Q000-0000306
137	110231	5	S/O Cord 12' Lg
138	100436	2	Gage (0-60 Psi.)
139	100351	1	Right Roof Grill
140	100559	4	.25 Lock Washer
141	100598	2	.25-20 Hex Nut
142	100557	2	.25-20 X .75 Lg SHCS
143	810725	1	Modified Throttle Bracket
144	130737	2	Suction Plug
145	400087	1	Pick-Up Filter
146	100938	1	FITT2L-16M12R000-000H001
147	400445	2	Flex Wrap Magnet
148	400173	1	FITT2S-48P40Q000-000H306
149	160283	2	6mm X 60mm SHCS
150	100524	1	Tube-4 x 4 x 11ga x 33
151	400163	1	#10-32 Hex Nut
152	120613	1	Water Separator Element
153	400247	21	Engine Oil/Quart
154	100394	1	Top Air Baffle
155	110246	1	Electric Actuator (24v)
156	130757	1	Throttle Actuator Linkage
157	810727	1	Modified Throttle Arm
158	110448	1	Adjustable Link
159	100631	1	.25-20 X 2.0 Lg SHCS
160	400203	1	FITT2S-06M06P000-000H001

230 POWER UNIT - INTERNAL

175003

<u>Item</u>	<u>Part Number</u>	<u>Qty.</u>	<u>Description</u>
161	100595	1	.25-20 X 1.25 Lg SHCS
162	100422	2	.25-20 UNC Esna Nut
163	100933	1	FITT2L-10R08M000-000H001
164	100851	4	.438-14 X 1.25 Lg SHCS
165	100428	1	Solenoid Bracket
166	130061	2	#10-32 X .50 BHCS S S
167	300671	2	#10 Flat Washer
168	400161	2	#10 Lock Washer
169	100398	20	Saddle Clip
170	110830	40	.25 X 2 In. Hex Tex Screw
171	100396	8	.312-18UNC x 1.50 Lg. SHCS
172	130467	1	Tach Sender

CONTROL MANIFOLD ASSEMBLY

173013

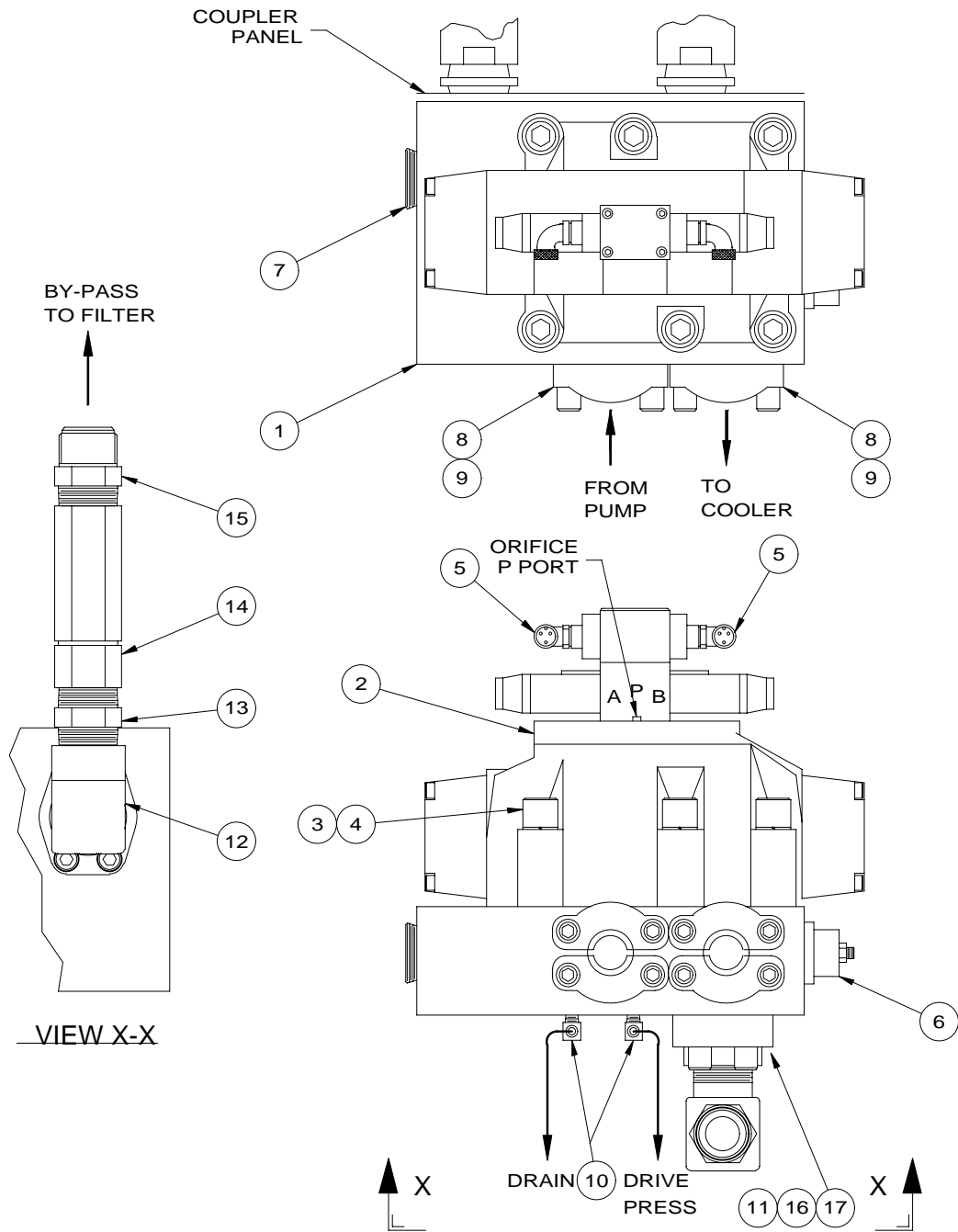

CONTROL MANIFOLD ASSEMBLY

173013

<u>Item</u>	<u>Part Number</u>	<u>Qty.</u>	<u>Description</u>
1	130501	1	175B Control Manifold
2	400786	1	4-Way Valve - 24V (V2)
3	400039	6	.75-10UNC X 2.75 Lg SHCS
4	100069	6	.75 Lock Washer Medium
5	100853	2	90 Deg S/O Comp Fitting
6	400742	1	Relief Cartridge (RV1)
7	110055	1	FITT2P-20P000000-000S007
8	100596	4	#24 Split Flange Half
9	100119	8	.5-13 X 1.25 LG SHCS Locwel
10	100145	2	FITT2L-04M04P000-0000001
11	110057	1	1.5 Solid Flange
12	100446	1	FITT2L-24P24Q000-0000001
13	110037	1	FITT2S-24P24P000-000H001
14	130339	1	1.5 Check Valve (CV5)
15	100565	1	FITT2S-24M24P000-000H001
16	100163	4	.5-13 X 1.75 Lg SHCS Locwel
17	100027	4	.5 Hi-Collar Lock Washer
18	110119	1	2-225 O-Ring

CLAMP MANIFOLD

810035

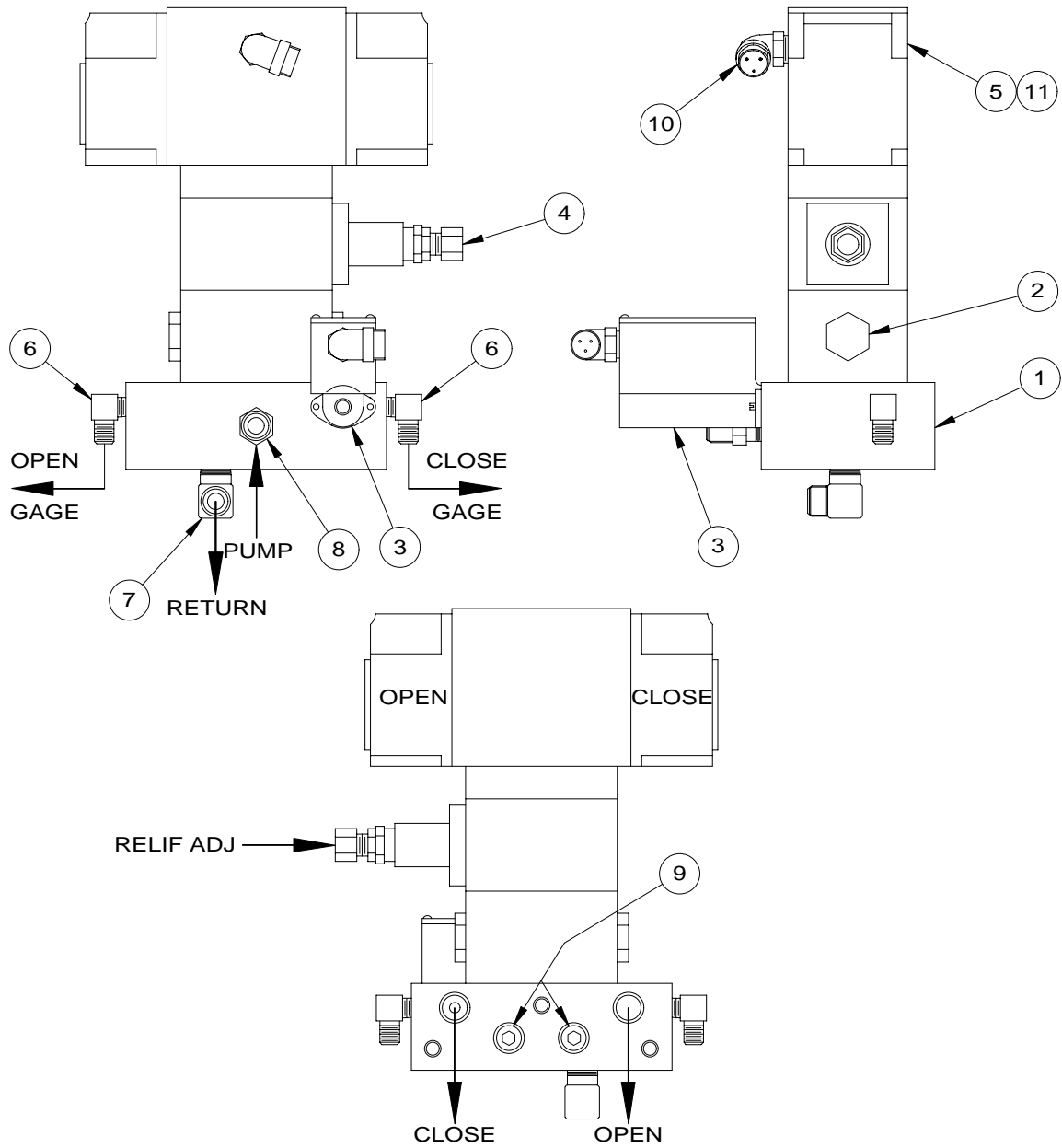

CLAMP MANIFOLD

810035

<u>Item</u>	<u>Part Number</u>	<u>Qty.</u>	<u>Description</u>
1	110642	1	Clamp Manifold Block
2	110149	1	Check Valve (CV1)
3	810033	1	Pressure Switch Assembly (PS-1)
4	100898	1	Sandwich Relief (RV2)
5	110147	1	Control Valve (V1A & B V2A & B)
6	140539	2	FITT2L-04M02P000-0000001
7	110632	1	FITT2L-12M06P000-000H001
8	110630	1	FITT2S-08M06P000-000H001
9	400213	2	FITT2P-06P000000-000S007
10	110235	1	90 Deg S/O Cord Adapter
11	110634	4	.25-20 X 7.5 Lg SHCS

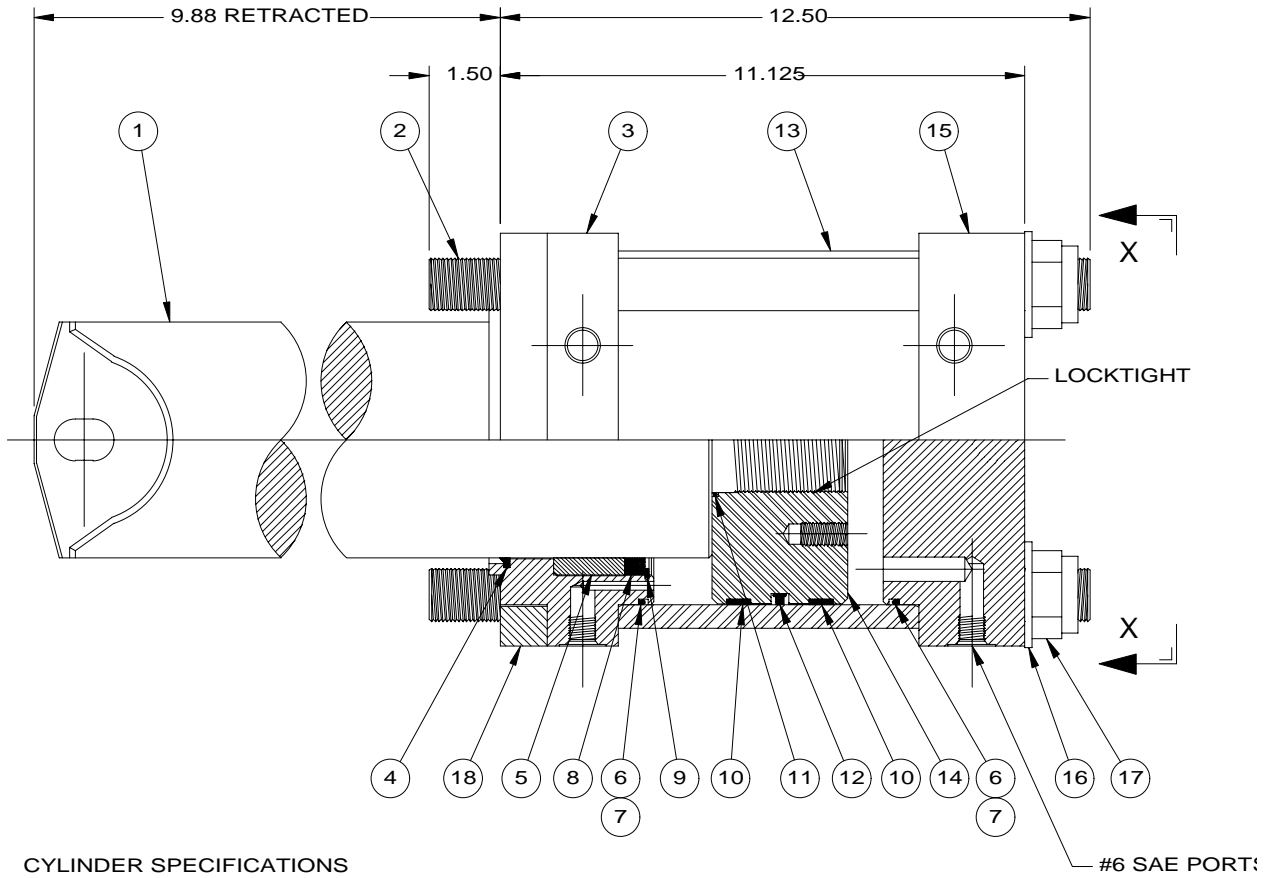

CYLINDER SPECIFICATIONS

BORE: 7.00 ϕ
 STROKE: 2.00
 ROD: 5.00 ϕ

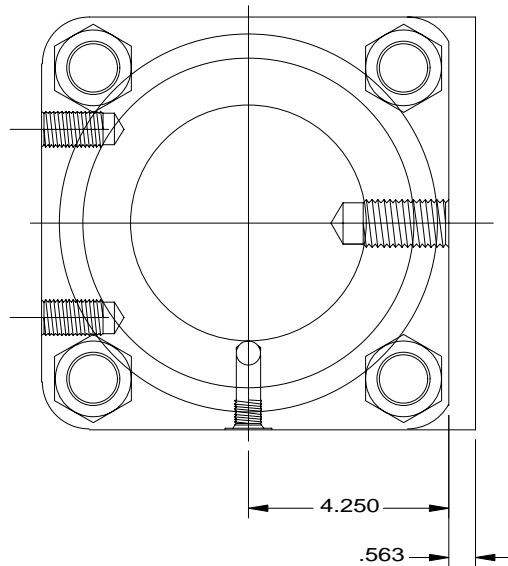

VIEW X-X

216 CLAMP ASM

810217

Item	Part Number	Qty.	Description
1	130439	1	Cylinder Rod
2	120309	4	Tie Rod - 80, 216
3	130415	1	Rod End Cap -216
4	120289	1	Rod Wiper (Note)
5	120267	1	Rod Bushing - 216, 122
6	120347	2	2-261 O-RING 90 DURO (Note)
7	120349	2	261 Back-Up Ring Pc Teflon (Note)
8	120287	1	Rod Seal (Note)
9	120291	1	Retaining Ring (Note)
10	120355	2	Piston Bearing (Note)
11	120281	1	2-140 O-RING (Note)
12	120357	1	Piston Seal (Note)
13	120315	1	Cylinder Tube - 80, 216
14	120313	1	Piston - 80, 216, WPH
15	130417	1	Piston End Cap - 216
16	120303	4	1.12 H. S. Flat Washer
17	120343	4	1.125 - 12 H. S. Hex Nut
18	130419	1	Front Plate -216
19	810225	1	216 Cylinder Seal Kit

Note: Included in 216 Cylinder Seal Kit

VIII. ORDERING PARTS

E. MISCELLANEOUS ACCESSORIES

1. Tools

Part Number	Qty.	Description
100651	1	24-Volt Test Light
100653	1	Set of Allen Wrenches - Includes All Wrenches Shown Below:
100655		(1) 1/16" Allen Wrench - Long Arm
100691		(1) 5/64" Allen Wrench - Long Arm
100659		(1) 3/32" Allen Wrench - Long Arm
100661		(1) 7/64" Allen Wrench - Long Arm
100663		(1) 1/ 8" Allen Wrench - Long Arm
100665		(1) 9/64" Allen Wrench - Long Arm
100667		(1) 5/32" Allen Wrench - Long Arm
100669		(1) 3/16" Allen Wrench - Long Arm
100671		(1) 7/32" Allen Wrench - Long Arm
100673		(1) 1/ 4" Allen Wrench - Long Arm
100657		(1) 5/16" Allen Wrench - Long Arm
100675		(1) 3/ 8" Allen Wrench - Long Arm
100677		(1) 7/16" Allen Wrench - Long Arm
100679		(1) 1/ 2" Allen Wrench - Long Arm
100681		(1) 9/16" Allen Wrench - Long Arm
100683		(1) 5/ 8" Allen Wrench - Long Arm
100685		(1) 3/ 4" Allen Wrench - Long Arm
100687		(1) 7/ 8" Allen Wrench - Short Arm
100689		(1) 1" Allen Wrench - Short Arm

2. Bulk

Part Number	Qty.	Description
810013	5 GAL	Hydraulic Oil
810011	5 GAL	Vibration Case Lubricant
100726	1 GAL	Coolant/Anti-Freeze
100298	1 GAL	I C E Green Paint
100299	1 GAL	Primer

VIII. ORDERING PARTS

E. MISCELLANEOUS ACCESSORIES (CONTINUED)

3. 11 Hose Group Kit - Internal 850165

Item	P/N	Qty.	Description	Page Ref.
27	130495	1	HOSE125R10F420H916L08900	VIII-7
28	130171	1	HOSE075R01F412P008L0910C	VIII-7
47	130497	1	HOSE125R10F420H916L09200	VIII-9
66	130173	1	HOSE038R02J006J006L1100C	VIII-9
67	130175	1	HOSE038R02J006J006L1150C	VIII-9

4. 230 Hose Group Kit - Internal 850163

Item	P/N	Qty.	Description	Page Ref.
20	130205	2	HOSE019AQ1J004J004L09000	VIII-17
21	130207	1	HOSE019R01J004J004L10000	VIII-17
7	100149	1	HOSE025R02J004J004L01900	VIII-24
59	100228	2	HOSE038R02J006J006L0610S	VIII-25
81	130201	2	HOSE075R01J012J012L04000	VIII-26
82	400215	1	HOSE100R01P016P016L08400	VIII-26
92	130515	1	HOSE150R02J024F924L10000	VIII-26
99	170307	1	HOSE150PT4F024F920L03200	VIII-26
100	130613	1	HOSE050PT4J008J008L02500	VIII-26
105	110586	1	HOSE150R01JO24J024L12900	VIII-26
109	170241	1	HOSE038R01J006J006L07000	VIII-26
110	100484	1	HOSE075R01J012J012L08400	VIII-26
111	100482	1	HOSE150R02J024J024L07200	VIII-26
130	100862	1	HOSE100R01J016J016L03300	VIII-27

5. 11/230 O-Ring Kit 850167

P/N	Qty.	Description
100037	3	O-ring (#222) 90 Duro
100091	2	O-ring (#219) 70 Duro
100097	1	O-ring (#214) 70 Duro
100814	4	Sealant (tube)
110119	1	O-ring (#225)
110197	1	O-ring (#159)
170311	1	O-ring (#151)

VIII. ORDERING PARTS

E. MISCELLANEOUS ACCESSORIES (CONTINUED)

6. Cylinder Seal Kit

MODEL 216 CLAMP CYLINDER

810225 Refer to page VIII-35

<u>Item</u>	<u>P/N</u>	<u>Qty</u>	<u>Description</u>
4	120289	1	Rod Wiper
6	120347	2	2-261 O-RING 90 DURO
7	120349	2	261 Back-Up Ring Pc Teflon
8	120287	1	Rod Seal
10	120355	2	Piston Bearing
11	120281	1	2-140 O-RING
12	120357	1	Piston Seal

VIII. ORDERING PARTS

F. RECOMMENDED SPARE PARTS

VIBRATION SUPPRESSOR 800027 Refer to page VIII-6

<u>Item</u>	<u>P/N</u>	<u>Qty.</u>	<u>Description</u>
4	130023	1	Elastomer
50	100032	1	Relief Valve

VIBRATION CASE 810037 Refer to page VIII-10

<u>Item</u>	<u>P/N</u>	<u>Qty.</u>	<u>Description</u>
8	130605	1	Sight Gauge
30	100814	1	Sealant (Tube)
--	130949	1	Motor Shaft Seal

HOSE ASSEMBLIES-INTERCONNECTING 800029 Refer to page VIII-12

<u>Item</u>	<u>P/N</u>	<u>Qty</u>	<u>Description</u>
5	100233	2	HOSE125R10P020P020L60000
9	100911	2	HOSE150R02P024P024L60000
13	100241	2	HOSE075R02P012P012L62000
17	100247	4	HOSE038R02P006P006L62000

POWER UNIT - INTERNAL (230) 175003 Refer to page VIII-22 & 23

<u>Item</u>	<u>P/N</u>	<u>Qty</u>	<u>Description</u>
--	130863	1	Oil Filter
14	100518	4	Return Hydraulic Oil Filter
--	130865	1	Fuel Filter Element
--	130753	1	Air Filter Element
99	170307	1	HOSE150PT4F024F920L03200
100	130613	1	HOSE050PT4J008J008L02500
111	100482	1	HOSE150R02J024J024L07200
130	100862	1	HOSE100R01J016J016L03300
152	120613	1	Water Separator Element

G. RECOMMENDED TIGHTENING TORQUE

Nominal Screw Size	Nominal Socket Size	Tightening Torque Ft-Lbs. (Kg-M)	Nominal Screw Size	Nominal Socket Size	Tightening Torque Ft-Lbs. (Kg-M)
#10-24	5/32	6 Ft-Lbs. (.83 Kg-M)	#10-32	5/32	6 Ft-Lbs. (.83 Kg-M)
1/4-20	3/16	13 Ft-Lbs. (1.8 Kg-M)	1/4-28	3/16	15 Ft-Lbs. (2.1 Kg-M)
5/16-18	1/4	27 Ft-Lbs. (3.7 Kg-M)	5/16-24	1/4	30 Ft-Lbs. (4.2 Kg-M)
3/8-16	5/16	48 Ft-Lbs. (6.6 Kg-M)	3/8-24	5/16	55 Ft-Lbs. (7.6 Kg-M)
7/16-14	3/8	77 Ft-Lbs. (10.6 Kg-M)	7/16-20	3/8	86 Ft-Lbs. (11.9 Kg-M)
1/2-13	3/8	119 Ft-Lbs. (16.4 Kg-M)	1/2-20	3/8	133 Ft-Lbs. (18.4 Kg-M)
5/8-11	1/2	234 Ft-Lbs. (32.3 Kg-M)	5/8-18	1/2	267 Ft-Lbs. (36.9 Kg-M)
3/4-10	5/8	417 Ft-Lbs. (57.6 Kg-M)	3/4-16	5/8	467 Ft-Lbs. (64.5 Kg-M)
7/8-9	3/4	676 Ft-Lbs. (93.4 Kg-M)	7/8-14	3/4	742 Ft-Lbs. (102.5 Kg-M)
1-8 M)	3/4	1,009 Ft-Lbs. (139.4 Kg-M)	1-12	3/4	1,126 Ft-Lbs. (155.6 Kg-M)
1-1/4-7 M)	7/8	1,600 Ft-Lbs. (221.1 Kg-M)	1-1/4-12	7/8	1,800 Ft-Lbs. (248.8 Kg-M)
1-1/2-6 M)	1	2,800 Ft-Lbs. (387 Kg-M)	1-1/2-12	1	3,000 Ft-Lbs. (414.6 Kg-M)

NOTE: These values are for Socket head cap screws only. Button heads, Flat heads and Set screws have different values. Check the Allen Hand Book for correct torque specifications.

