



MODEL 66-80
VIBRATORY
DRIVER/EXTRACTOR

OPERATING AND MAINTENANCE MANUAL

J&M MODEL 66-80

VIBRATORY PILE DRIVER/EXTRACTOR

WITH MODEL 800 POWER PACK



**J&M FOUNDATION
EQUIPMENT, LLC**

OM-66-80/800-1106

SPECIALIZING IN PILE DRIVING EQUIPMENT



**MODEL 66-80
VIBRATORY
DRIVER/EXTRACTOR**



**MODEL 66-80
VIBRATORY
DRIVER/EXTRACTOR**

PREFACE

This manual was prepared to acquaint the owner, operator and serviceman with the operation and maintenance of the vibratory driver/extractor. We suggest that this manual be carefully studied before operating or undertaking any maintenance work on the unit.

This manual is organized into two major sections.

The first contains routine OPERATING INSTRUCTIONS for the unit and includes a GENERAL DESCRIPTION section, which presents a basic explanation of the driver/extractor and its specifications. The MAINTENANCE AND ADJUSTMENT section should be referred to periodically for normal servicing of equipment. All machines and equipment require systematic, periodic inspection and maintenance if they are to perform satisfactorily over a long period of time. The driver/extractor is primarily a vibrating machine and if not given the best of care, or if improperly used and maintained, it is self-destructive. Therefore, the unit should receive the same care and maintenance as other high quality construction equipment.

The second category is for parts ordering and it includes both a PARTS LIST and a pictorial drawing of the assembly, for easier determination of the required part(s). Refer to the ORDERING PARTS section of the PARTS LIST for more specific procedures regarding parts ordering. Adherence of the listed procedures will insure receipt of the required part(s) with the minimal amount of delay or error.



**MODEL 66-80
VIBRATORY
DRIVER/EXTRACTOR**



**MODEL 66-80
VIBRATORY
DRIVER/EXTRACTOR**

WARRANTY

J&M FOUNDATION EQUIPMENT LLC. STANDARD WARRANTY

J&M Foundation Equipment LLC (J&M) warrants new products sold by it to be free from defects in material or workmanship for a period of 90 days after date of delivery to the first user and subject to the following conditions:

J&M's obligation and liability under this WARRANTY is expressly limited to repairing or replacing, at J&M's option, any parts which appear to J&M, upon inspection, to have been defective in material or workmanship. Such parts shall be provided at no cost to the user, at the business establishment of J&M or the authorized J&M distributor of the product, during regular working hours. This WARRANTY shall not apply to component parts or accessories of products not manufactured by J&M and which may carry the warranty of the manufacturer thereof, or to normal maintenance (such as engine tune-up) or to normal maintenance parts (such as oil filters). Replacement or repair parts installed in the product covered by this WARRANTY are warranted only for the remainder of the warranty, as if such parts were original components of said product. **J&M COMPANY MAKES NO OTHER WARRANTY, EXPRESS OR IMPLIED, AND MAKES NO WARRANTY OF MERCHANTABILITY OR FITNESS, FOR ANY PARTICULAR PURPOSE.**

J&M's obligation under this WARRANTY shall not include any transportation charges, cost of installation, duty, taxes or any other charges whatsoever, or any liability for direct, indirect, incidental, or consequential damage of delay. If requested by J&M, products or parts for which a warranty claim is made are to be returned, transportation prepaid to J&M. Any improper use, including operation after discovery of defective or worn parts, operation beyond rated capacity, substitution of parts not approved by J&M or any alteration or repair by others in such manner as in J&M's judgment affects the product materially and adversely, shall void this WARRANTY.

NO EMPLOYEE OR REPRESENTATIVE IS AUTHORIZED TO CHANGE THIS WARRANTY IN ANY WAY OR GRANT ANY OTHER WARRANTY UNLESS SUCH CHANGE IS MADE IN WRITING AND SIGNED BY AN OFFICER OF J&M.



**MODEL 66-80
VIBRATORY
DRIVER/EXTRACTOR**

TABLE OF CONTENTS

OPERATING INSTRUCTIONS

I.	<u>GENERAL DESCRIPTION</u>	<u>PAGE</u>
A.	General	I- 1
B.	Vibrator	I- 2
C.	Hydraulic Clamp	I- 2
D.	Power Unit	I- 2
E.	Hoses	I- 2
F.	Remote-Control Pendant	I- 2
G.	Specifications	I- 3
II.	<u>PREPARATION FOR OPERATION</u>	
A.	General	II- 1
B.	Safety Precautions	II- 1
C.	Rigging of Vibrator	II- 2
D.	Connection of Hydraulic Clamp	II- 2
E.	Connection of Hydraulic Hoses	II- 3
F.	Bleeding Hydraulic Clamp Hoses	II- 5
G.	Filling Vibrator Pressure Hose	II- 5
III.	<u>OPERATING INSTRUCTIONS</u>	
A.	Completion of Set-Up and Maintenance	III- 2
B.	Control Panel	III- 2
C.	Starting and Warming Up Engine	III- 4
D.	Warming Hydraulic Oil	III- 4
E.	Operation of Remote-Control Pendant	III- 5
F.	Changing Frequency	III- 7
G.	Shutdown	III- 7
IV.	<u>MAINTENANCE AND ADJUSTMENTS</u>	
A.	General	IV- 1
B.	Daily Maintenance	IV- 1
C.	125 Hours (Service Meter Units)	IV- 2
D.	250, 500 Hours and Other	IV- 2
E.	Annual Maintenance	IV- 2
F.	Maintenance Under Severe Conditions	IV- 3
G.	Lubrication	IV- 4
H.	Draining and Filling Hydraulic Oil Reservoir	IV- 8
I.	Changing Hydraulic Return Filter Elements	IV- 9
J.	Bolt Torque Information	IV-10



**MODEL 66-80
VIBRATORY
DRIVER/EXTRACTOR**

TABLE OF CONTENTS

OPERATING INSTRUCTIONS (CONTINUED)

<u>V.</u>	<u>HYDRAULIC CIRCUITRY</u>	<u>PAGE</u>
A.	Hydraulic Clamp	V- 1
B.	Vibrator Drive Motor	V- 1
C.	Other	V- 3
	Hydraulic Schematic	V- 4
D.	Hydraulic Components List	V- 5
<u>VI.</u>	<u>ELECTRICAL CIRCUITRY</u>	
A.	Starting Diesel Engine	VI- 1
B.	Stopping Diesel Engine	VI- 1
C.	Safety Control System	VI- 1
D.	Closing Hydraulic Clamp	VI- 2
E.	Opening Hydraulic Clamp	VI- 2
F.	Starting Vibrator	VI- 3
G.	Stopping Vibrator	VI- 3
H.	Other	VI- 3
	Electrical Layout	VI- 4
	Electrical Schematic	VI- 5
I.	Electrical Components List	VI- 6

PARTS LIST

<u>VII.</u>	<u>GENERAL DATA</u>	
A.	Abbreviations	VII- 1
B.	Screws and Bolts	VII- 1
C.	Serial Number Locations	VII- 2
<u>VIII.</u>	<u>ORDERING PARTS</u>	
A.	Procedure	VIII- 1
B.	Fitting Description Key	VIII- 2
	Fitting Style Selector Chart - SC1	VIII- 3
C.	Hose Description Code	VIII- 4
D.	Parts Identification	VIII- 5
	Parts Lists and Drawings	VIII- 6
E.	Miscellaneous Accessories	VIII-48
F.	Recommended Spare Parts	VIII-51
G.	Recommended Tightening Torque	VIII-53



**MODEL 66-80
VIBRATORY
DRIVER/EXTRACTOR**



**MODEL 66-80
VIBRATORY
DRIVER/EXTRACTOR**

OPERATING INSTRUCTIONS

I. GENERAL DESCRIPTION

A. GENERAL

The J&M Model 66 is a variable-frequency vibratory pile driver/extractor designed to drive and extract sheet, pipe, timber and concrete piles, caissons, H-beams, I-beams and wide-flange beams.

The Model 66 operates in a frequency range of 800 to 1600 vibrations per minute to provide maximum pile penetration rates in a wide variety of soils. The unit has an eccentric moment of 6600 inch-pounds (76 kg-M) and produces a maximum amplitude of 1.23 inch (30mm).

The vibratory driver unit consists of two major components - (1) the vibrator with attached clamp and (2) the power unit with remote control pendant.

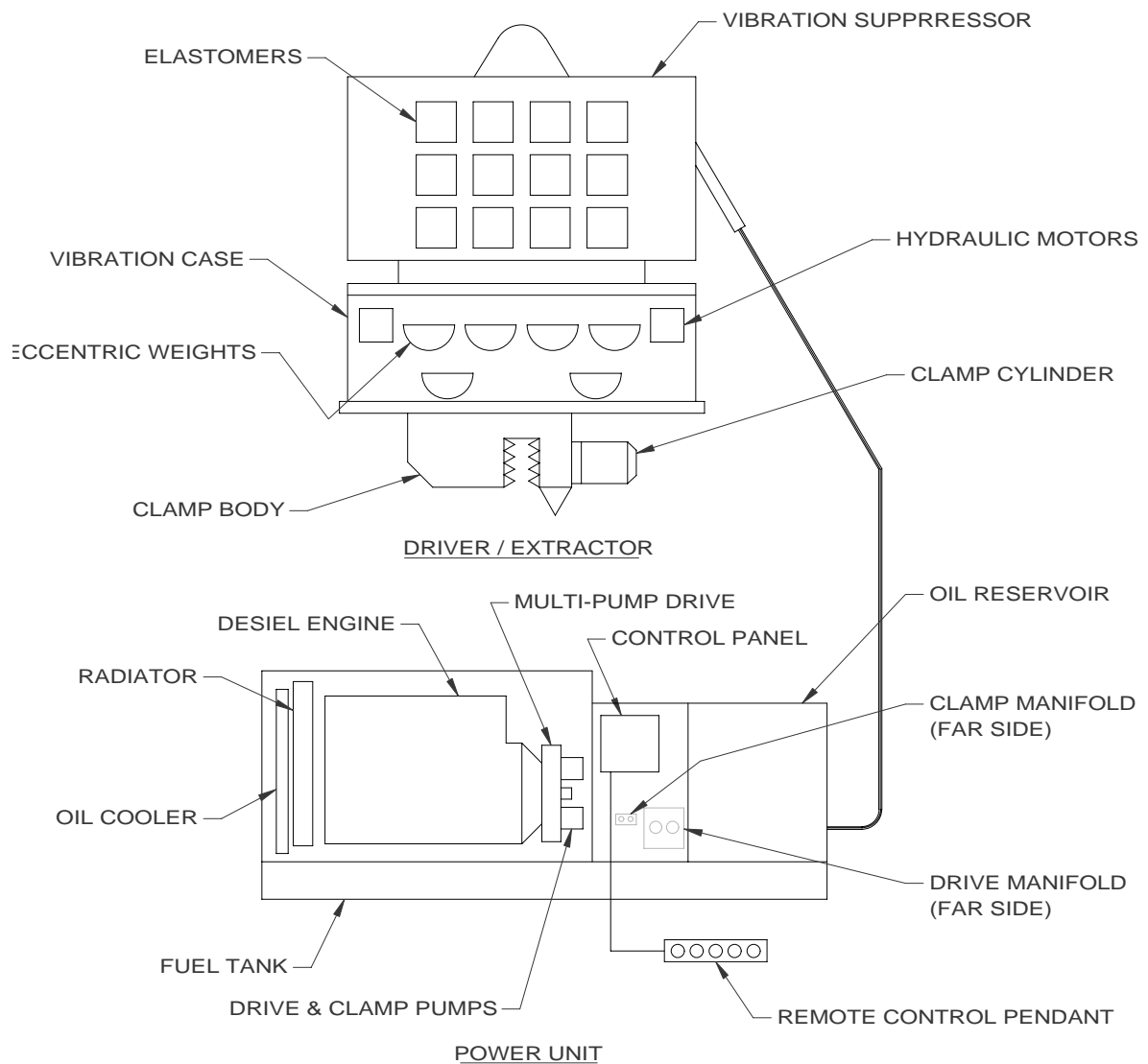



**MODEL 66-80
VIBRATORY
DRIVER/EXTRACTOR**

OPERATING INSTRUCTIONS

I. GENERAL DESCRIPTION

B. VIBRATOR

The vibrator consists of two major components; The vibration case and the vibration suppressor. The vibration case contains six eccentric weights which rotate in a vertical plane to create vibration. The eccentric weights are driven by two hydraulic motors. The vibration suppressor contains a minimum of 24 rubber elastomers to isolate the vibration case from the crane line. The suppressor is designed for a maximum line pull of 80 tons (712kN) during extraction.

C. HYDRAULIC CLAMP

The hydraulic clamp attaches the vibrator to the pile. Four types of hydraulic clamps are available for the Model 66 vibrator. The Model 196 universal clamp will drive and extract most types of sheet piling, 14" (355mm) H-beams, and wide flange beams. The Model 122 caisson clamps are used in pairs with either the 7-foot (2.13m) or 11-foot (3.35m) caisson beam to drive and extract pipe from 22.25" (565mm)ID to 129.25" (3283mm)OD. The Model 50 wood pile clamp is designed to drive and extract wood piles from 10" (254mm) OD to 18" (457mm) OD. The model 165 concrete pile clamp will extract square concrete piles from 18" (457mm) to 24" (610mm).

D. POWER UNIT

The Model 66 vibrator is powered by the J&M Model 950 power pack. The 950 power pack is powered by a Caterpillar 3412DIT diesel engine. The engine develops 800 horsepower (597kW) at 1900 RPM, and is mounted on a tubular sub-base which serves as a fuel tank. The Power Unit and Vibrator are operated from the control panel or remote control pendant. Hydraulic oil is stored in the reservoir. Oil cooling is accomplished by a air to oil heat exchanger mounted in front of the engine radiator. All of the above components are contained in a sheet metal enclosure, with lockable doors, and a central lifting bale. Five hydraulic pumps are mounted to the engine via a multi-output gear box.

E. HOSES

Three hydraulic hoses, 150 feet (45.7m) in length, connect the power unit to the hydraulic motors on the vibrator. Two other hydraulic hoses run from the power unit to the hydraulic clamp.

F. REMOTE-CONTROL PENDANT

The vibrator is operated by the hand-held remote control pendant. The pendant has 1 palm button, 2 switches and 2 push buttons, 1 with a light. The red palm button (EMERGENCY STOP) shuts down diesel engine instantly in the event of an emergency. The (OPEN CLOSE) switch opens and closes the hydraulic clamp. The light in the (START) button indicates that adequate clamping pressure exists. The (START) button starts vibration. The (STOP) button stops vibration. The (THROTTLE) switch raises and lowers the diesel engine speed. Note: Controls are duplicated on the control panel for use if the pendant becomes damaged. (See pg.III-6, Section E-g)



**MODEL 66-80
VIBRATORY
DRIVER/EXTRACTOR**

OPERATING INSTRUCTIONS

I. GENERAL DESCRIPTION

G. SPECIFICATIONS

1. Constant improvement and engineering progress make it necessary that we reserve the right to make specification changes without notice.

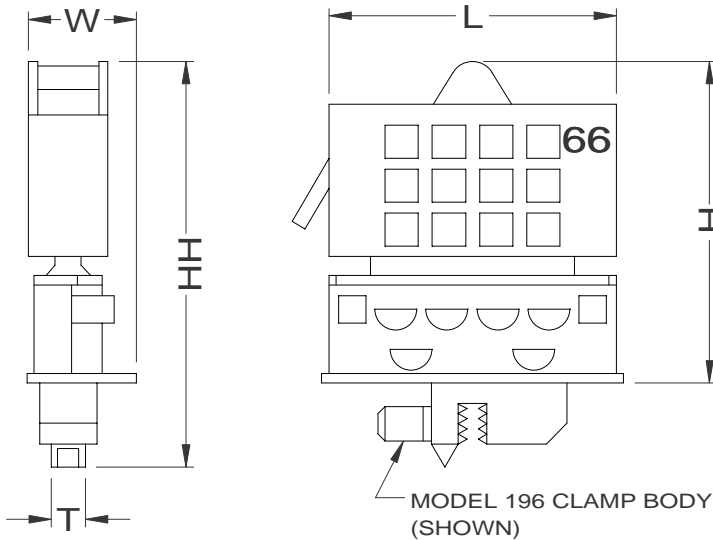

2. MODEL 66-80 VIBRATOR
(with hydraulic clamp)

Type.....	Hydraulic
Eccentric Moment.....	6600 In-lbs (50.7kg-M)
Frequency.....	800-1600 VPM
Amplitude.....	1.23 in. (30mm)
Pile Clamping Force.....	196 Tons(1744kN)
Max. Line Pull for Extraction.....	80 Tons (712kN)
Suspended Weight with 196 Clamp and half hoses.....	19,200 lbs. (8708kg)
Length [L].....	97 in. (246cm)
Width [W].....	21 in. (55cm)
Throat Width [T].....	14.25 in. (36cm)
Height with Clamp [HH].....	137.75 in. (350cm)
Height without clamp [H].....	99.75 in. (253cm)

3. MODEL 650 POWER UNIT

Type.....	Diesel
Engine.....	CAT 3412DITA
Horsepower (2100 RPM).....	800 (597kW)
Weight.....	23,000 lbs.(10433kg)
Length [ll].....	186 in. (472cm)
Width [ww].....	66 in. (168cm)
Height [hh].....	100 in. (254cm)

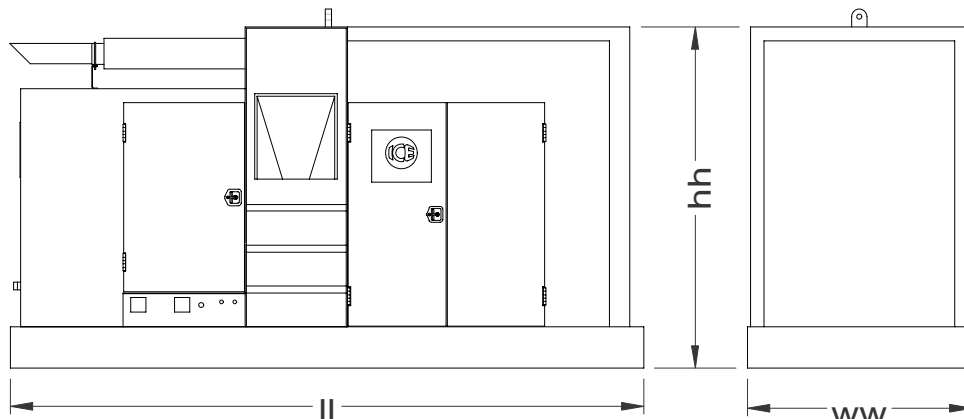

II. PREPARATION FOR OPERATION



MODEL 66-80
VIBRATORY
DRIVER/EXTRACTOR

OPERATING INSTRUCTIONS

II. PREPARATION FOR OPERATION

A. GENERAL

When unloading and unpacking the vibratory driver, use extreme care. For your protection, make a thorough inspection of the unit immediately on delivery. In case of any damage or shortage, notify the transit agent at once and have the delivering carrier make a notation on the freight bill.

B. SAFETY PRECAUTIONS

Safety is basically common sense. There are standard safety rules, but each situation has its own peculiarities which cannot always be covered by rules. Therefore, your experience and common sense will be your best guide to safety. Be ever watchful for safety hazards and correct deficiencies promptly.

Use the following safety precautions as a general guide to safe operations:

1. Read this manual thoroughly before operating or working on the equipment.
2. Read and follow any safety instructions in the CATERPILLAR engine operators manual.
3. Only well trained and experienced personnel should attempt to operate or maintain this equipment.
4. Never adjust, lubricate or repair the unit when it is in operation, or lifted above ground level.
5. Never remove, paint over or cover warning or safety labels. If labels become damaged or unreadable, replace immediately.
6. All personnel should wear approved safety clothing, including **HARD HATS, SAFETY SHOES, SAFETY GLASSES** and **HEARING PROTECTION** when in the vicinity of this machinery.
7. Do not stand any closer to this equipment than necessary when it is in operation. Parts may loosen and fall. Never stand under operating, or elevated, equipment.
8. When maintaining or repairing the equipment, never substitute parts not supplied, or approved in writing, by J&M.
9. Do not weld, or flame cut, on this equipment.
10. Never use or store flammable liquids on or near the engine.
11. Insure that all lifting equipment, including cranes, wire rope, slings, hooks, shackles, etc., are properly sized for the worst case loads anticipated during operations.
12. If there are any questions about the weights, specifications, or performance of the unit, contact J&M before handling or operating the equipment.
13. If the equipment is to be used for anything other than driving or extracting plumb piles, contact J&M before using the unit.
14. Check wire rope clips for tightness, and check wire ropes for wear, daily.
15. Insure that ground vibrations will not damage or collapse adjacent structures or excavations.
16. Remove all tools, parts and electrical cords before starting the unit.
17. When operating in an enclosed area, pipe exhaust fumes outside. Continued breathing of exhaust fumes may be fatal.



MODEL 66-80
VIBRATORY
DRIVER/EXTRACTOR

OPERATING INSTRUCTIONS

II. PREPARATION FOR OPERATION

B. SAFETY PRECAUTIONS (CONTINUED)

18. When servicing batteries, do not smoke or use open flames in the vicinity. Batteries generate explosive gas during charging. There must be proper ventilation when charging batteries.
19. When filling fuel tank, do not smoke or use open flame in the vicinity.
20. If abnormal equipment operation is observed, discontinue use immediately and correct the problem. Do not leave the equipment control pendant (radio control) unattended.
21. Store oily rags in approved containers, and away from engine exhaust system.
22. Make sure that the vibrator is OFF before starting the power unit engine.
23. Do not adjust, or set, hydraulic pressures higher or lower than those specified in this manual.
24. Never operate this equipment with hydraulic hoses that are damaged or "kinked". Replace damaged hoses immediately.
25. Do not lift, or support, hydraulic hoses with wire rope slings.
26. Never attempt to connect quick disconnects when the power unit is running.
27. Do not pull on, or attempt to move equipment, with hydraulic hoses.
28. Do not attempt to locate hydraulic leaks with your hands. High pressure hydraulic leaks can penetrate the skin, causing severe damage, blood poisoning and infection. Do not attempt to repair leaks while the equipment is in operation.
29. Do not attempt to tighten, or loosen, fittings or hoses when the machine is in operation.
30. Power unit must always be placed on level, stable, ground.
31. Do not remove power unit heat shields, or operate power unit without heat shields. Severe fires may result.
32. A properly maintained fire extinguisher, suitable for oil fires, must be kept in the immediate vicinity of equipment operations.
33. When moving or transporting this equipment, insure that the vehicle or vessel is of sufficient capacity to handle the load, and that the equipment is properly tied down.
34. When moving or transporting this equipment, be sure that quick disconnect dust caps are tight, and that cap safety cables are in place. Be sure that all equipment parts are tight, or properly secured, before shipment. Unsecured parts may vibrate loose and fall, during transport, causing injury or property damage.
35. Keep crane boom, piles, leads, wire rope and other equipment at least 15' (5M) from electrical power lines, transformers and other electrical equipment, or at such distance as required by applicable safety codes.
36. Rounded or damaged bolt heads or nuts should be replaced so that proper torque values may be obtained. Proper torque values are necessary to prevent parts on this equipment, leads and crane boom from loosening and falling. Refer to Torque Chart, in this manual, for proper values.
37. When using the vibrator to move piles we recommend using a safety line in case of loss of hydraulic pressure.



MODEL 66-80
VIBRATORY
DRIVER/EXTRACTOR

OPERATING INSTRUCTIONS

II. PREPARATION FOR OPERATION

B. SAFETY PRECAUTIONS (CONTINUED)

38. Never clamp vibrator to pile and disconnect the crane line. Loss of hydraulic pressure could cause vibrator to fall. Lay vibrator down when not in use.
39. When extracting piles, always attach a safety line between pile and crane hook.
40. When extracting piles, check crane load/radius tables to be sure crane capacity is adequate for maximum allowable extraction pull.
41. When extracting piles, or any other driving operations, always be sure that the crane line is aligned with the centerline of the pile. Do not side load crane boom or vibrator. Dangerous crane boom, or vibrator, damage may result.
42. When extracting piles, do not exceed the capacity of the vibrator suppressor. Continued operation against the safety stops will cause damage to the crane boom and the vibrator.
43. Never induce line pull on a vibrator before starting the unit in vibration. Always start both driving and extraction of piles with a slack line.
44. Keep hands away from clamp jaws.
45. Keep hands away from vibrator suppressor during operation. Clearances may change causing pinch points.
46. Do not run vibrator unless clamp jaws are closed.
47. Use tag line to control vibrator whenever possible.
48. When driving "batter" piles, insure that the leads, and crane boom, have sufficient bending strength to handle the worst case load. Consult J&M.

REMEMBER, SAFETY IS EVERYONE'S BUSINESS.

C. RIGGING OF VIBRATOR

A steel wire rope sling must be connected to the lifting pin of the vibration suppressor. The required strength of this sling depends on the capacity of the crane and the work to be carried out. A safety factor of five is recommended, (5 x 80 ton). Several turns of a smaller diameter cable will usually last longer than one turn of a larger diameter cable. Inspect daily for damage to sling or wire rope clamps.

The vibrator is usually shipped with the hydraulic clamp already attached.

D. CONNECTION OF HYDRAULIC CLAMP

If the clamp is not attached, it will be necessary to attach it to the bottom of the vibrator. Orient the clamp to the vibrator with the clamp cylinder end (movable jaw) at the same end of the vibrator at which the hose chute is mounted. All eleven (1.5-6UNC x 5.00lg) bolts must be in place and torqued to approximately 2800 ft-lbs. (387 Kg-M)

For caisson work, the caisson beam must be attached to the bottom of the vibrator and tightened as above. Then slide the clamps into position onto the beam.



MODEL 66-80
VIBRATORY
DRIVER/EXTRACTOR

OPERATING INSTRUCTIONS

II. PREPARATION FOR OPERATION

E. CONNECTION OF HYDRAULIC HOSES

1. Connection of hoses at power unit.

- a. The vibrator and hydraulic clamp are connected to the power unit by five hydraulic hoses (Fig. 1).
CAUTION: The power unit must be shut down during connection of the hydraulic hoses.
- b. The hoses connect to the power unit with quick-disconnect couplers. The hose couplers are arranged to insure correct connections at the power unit. See the diagram (Fig. 1) below for correct hose connection.
- c. Clean couplers with a lint-free cloth before making connections.
- d. Make sure that the couplers are fully run up. They should be fully hand tight. Do not use wrenches to tighten.

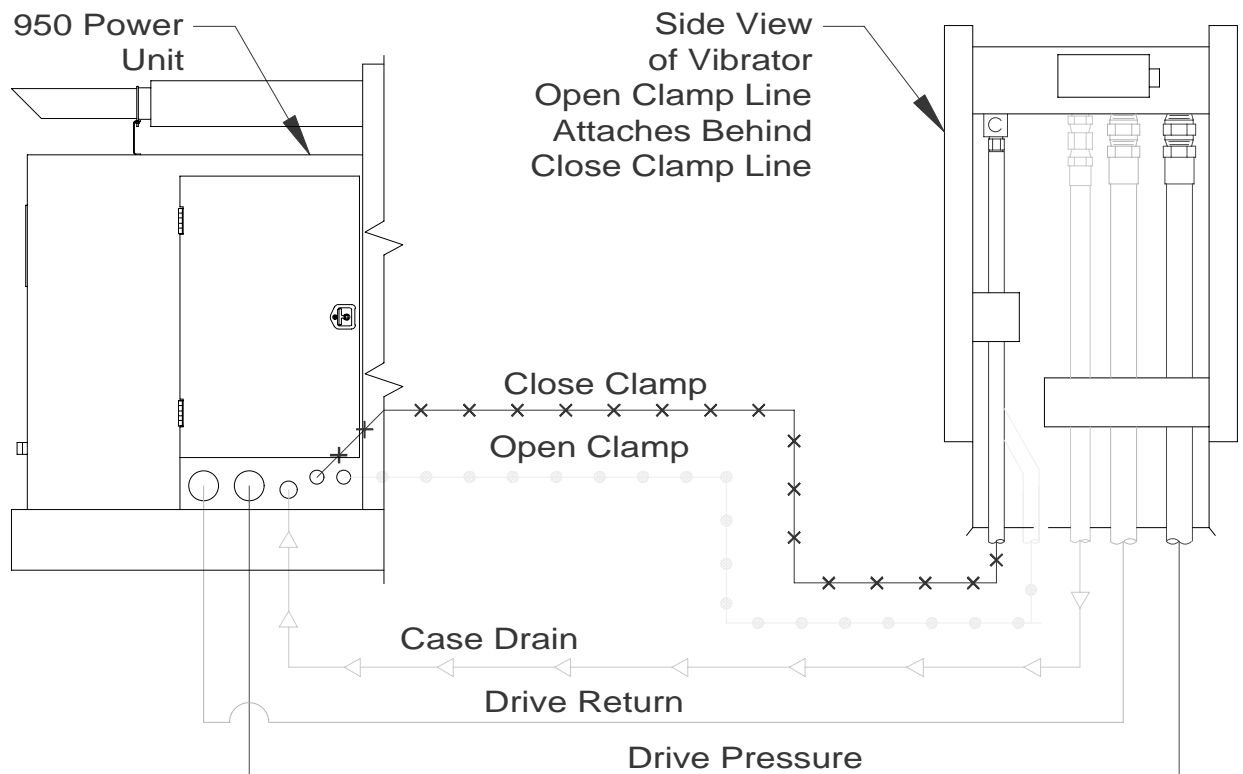

(Fig. 1)



MODEL 66-80
VIBRATORY
DRIVER/EXTRACTOR

OPERATING INSTRUCTIONS

II. PREPARATION FOR OPERATION

E. CONNECTION OF HYDRAULIC HOSES (CONTINUED)

2. Connection of hoses at vibrator.

- a. The vibrator is usually shipped with the hoses attached to the vibrator. If the hoses have been shipped separately, they must be connected in the field. Fig. 1 on the previous page shows the correct arrangement of the 5 hoses connecting the power unit to the vibrator.

CAUTION: Starting the vibrator with the hoses reversed will result in low power or possible ruptured hoses.

- b. The vibrator is usually shipped with the hydraulic clamp and hoses attached. If the clamp has been shipped separately, the two hoses connecting the clamp to the vibrator must be connected. Fig. 2 shows the correct arrangement of these hoses. For caisson clamps, four hoses must be connected. The two connections on the opposite end of the vibrator are reversed from the positions shown on the drawing below. Both ends are stamped with an "O"(open) and a "C"(close) to insure correct connection. The clamp connections are the same.

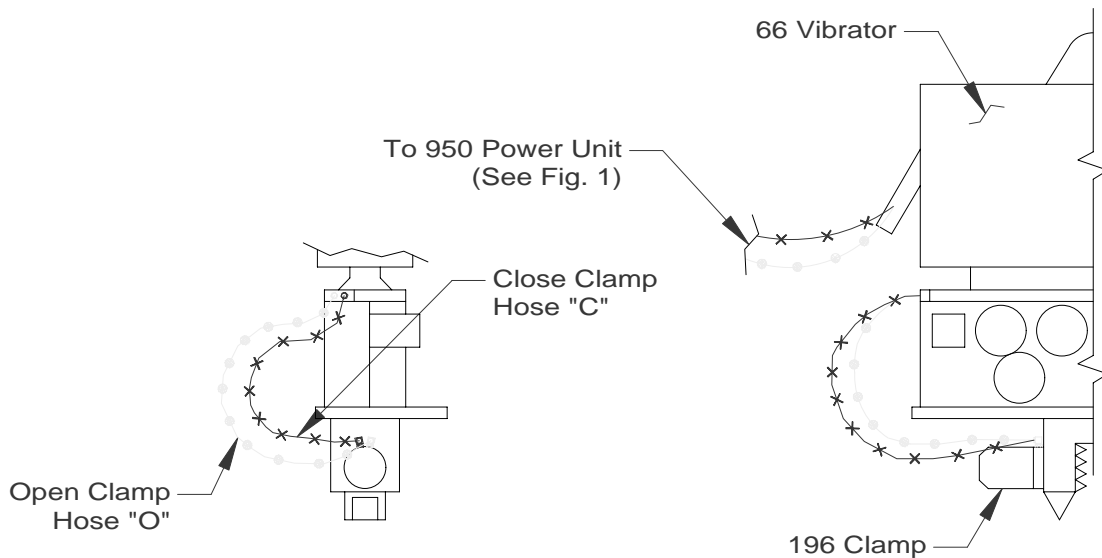

(Fig. 2)



MODEL 66-80
VIBRATORY
DRIVER/EXTRACTOR

OPERATING INSTRUCTIONS

II. PREPARATION FOR OPERATION

F. BLEEDING HYDRAULIC CLAMP HOSES

1. When the vibrator and hydraulic clamp are shipped with all hoses attached (between vibrator and clamp and five main hoses connected to the vibrator), the hoses are usually full of oil and may be used immediately. However, if any of the clamp hoses are connected at the job site or if air is present in hoses, they must be bled prior to operation.
2. Read SECTION III - OPERATING INSTRUCTIONS.
3. Start and warm up the diesel engine in accordance with SECTION III-C - STARTING AND WARMING UP ENGINE.
4. With the engine warmed-up and running at 1200 RPM, loosen the close-clamp line at the hydraulic clamp. Turn the clamp switch on the remote-control pendant to CLOSE. Wait until oil flows from the connection at the hydraulic clamp. When oil flows without air, tighten the connection.
5. After the line has been bled, alternately turn the clamp switch to CLOSE and OPEN to insure that the clamp is working properly. It may be necessary to bleed the line more than once. The open-clamp line may also require bleeding.

G. FILLING VIBRATOR PRESSURE HOSE

1. The vibrator is usually shipped with the vibrator hydraulic hoses full of oil and the unit may be used immediately. However, if the pressure hose has been removed from the vibrator, the hose should be allowed to fill with hydraulic oil prior to fullspeed operation.
2. Read SECTION III - OPERATING INSTRUCTIONS.
3. Start and warm up the diesel engine in accordance with SECTION III-C - STARTING AND WARMING UP ENGINE.
4. With the diesel engine running at 1800 RPM, the Vibrator hoses will fill with oil in about 10 minutes. Do not press the START button on control pendant.



MODEL 66-80
VIBRATORY
DRIVER/EXTRACTOR

OPERATING INSTRUCTIONS

III. OPERATING INSTRUCTIONS

CONTROL PANEL WITH REMOTE-CONTROL PENDANT

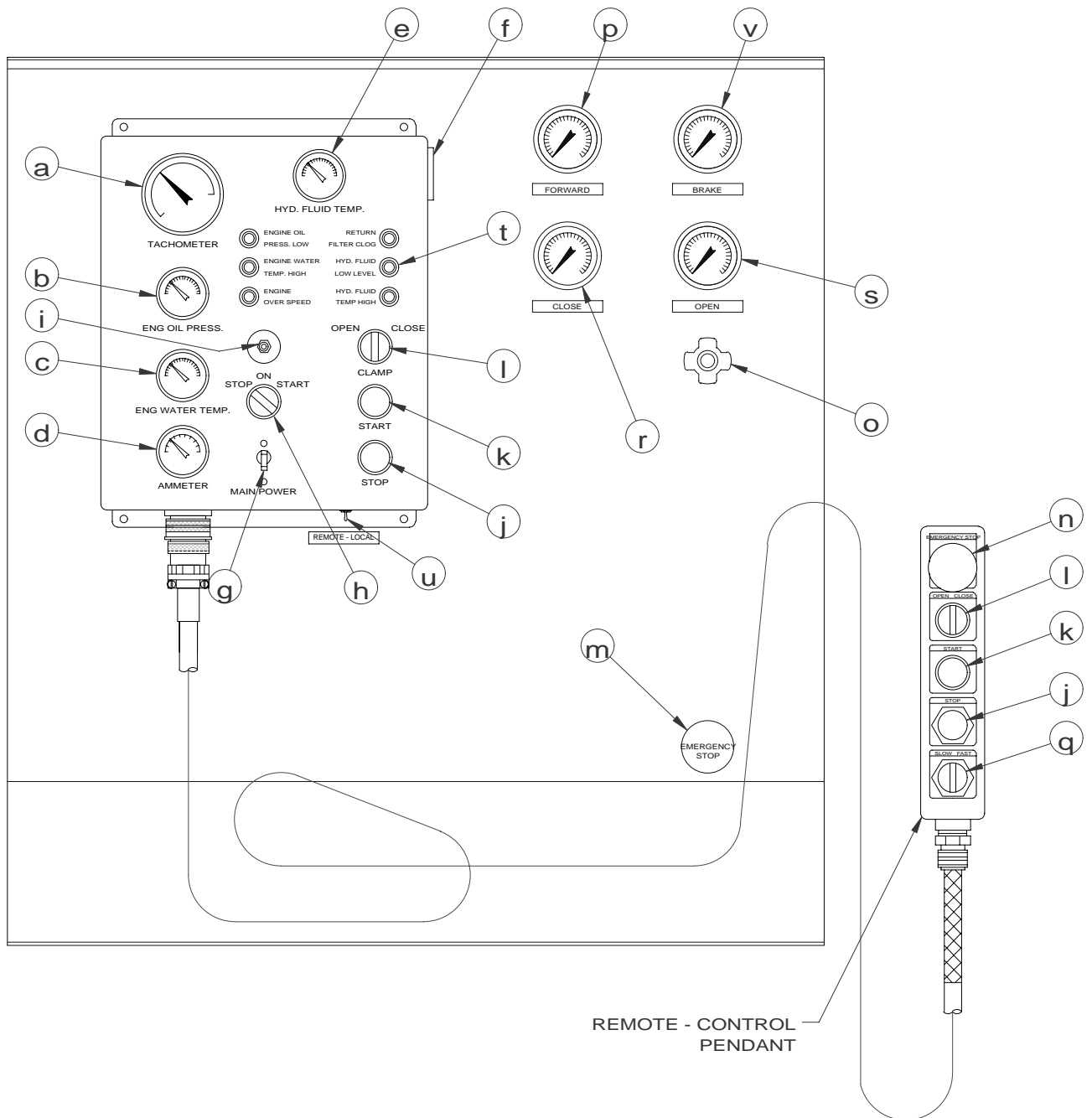

(Fig. 1)



MODEL 66-80
VIBRATORY
DRIVER/EXTRACTOR

OPERATING INSTRUCTIONS

III. OPERATING INSTRUCTIONS

A. COMPLETION OF SET-UP AND MAINTENANCE

1. Complete all preparation as described in Section II.
2. Read Section IV - MAINTENANCE AND ADJUSTMENTS and perform any required maintenance.

B. CONTROL PANEL

1. The control box (Fig. 1, page III-1) at the side of the power pack contains the controls and gages for the diesel engine and the vibrator and the OPERATION AND MAINTENANCE INSTRUCTIONS.
2. Control panel contains the following controls, gages and shutdown indicators.
 - a. Engine Tachometer
 - b. Engine Oil Pressure Switch Gage
 - c. Engine Water Temp Switch Gage
 - d. Engine Ammeter
 - e. Hydraulic Oil Temperature Switch Gage
 - f. Engine Hour Meter
 - g. Main Power Switch - ON-OFF Switch & Circuit Breaker
 - h. Engine - ON-OFF-START - Switch for Diesel Engine
 - i. Engine Shutdown Reset Button - over ride button for engine shutdown switch. Must be held in until oil pressure exceeds 30 PSI.
 - j. Vibrator Stop Button
 - k. Vibrator Start Button - with clamp light.
 - l. Clamp Switch - open - close.
 - m. Emergency Stop - pull out to stop engine.
 - n. Emergency Stop - push to stop engine.
 - o. Engine Throttle (Manual)
 - p. Pressure Gage - Forward
 - q. Engine Throttle (Remote Electric)
 - r. Pressure Gage - Close Clamp
 - s. Pressure Gage - Open Clamp
 - t. Shutdown indicator lights (6) See notes below.
 - u. Remote - Local Switch
 - v. Pressure Gage - Brake

- Notes:
1. Engine Oil Pressure shutdown indicator - comes on if engine has been shut down automatically due to engine oil pressure being low.
 2. Engine Water Temperature shutdown - comes on if engine has been shut down automatically due to engine water overheating.



MODEL 66-80
VIBRATORY
DRIVER/EXTRACTOR

OPERATING INSTRUCTIONS

III. OPERATING INSTRUCTIONS

B. CONTROL PANEL (CONTINUED)

3. Engine Overspeed shutdown indicator - comes on if engine has been shut down automatically due to the engine being run at excessively high RPM.
 4. Filter Clogged shutdown indicator - comes on if engine has been shut down automatically due to the hydraulic oil return filter being clogged.
 5. Hydraulic Oil Level Low shutdown indicator comes on if engine has been shut down automatically due to low hydraulic oil level in the reservoir.
 6. Hydraulic Oil Temperature High shutdown indicator - comes on if engine has been shut down automatically due to high hydraulic oil temperature.
3. The Operating & Maintenance Instructions, on the control box door, are there as reminders only. They are not intended to substitute for a through understanding of the Operators Manual.



MODEL 66-80
VIBRATORY
DRIVER/EXTRACTOR

OPERATING INSTRUCTIONS

III. OPERATING INSTRUCTIONS

C. STARTING AND WARMING UP ENGINE

1. Before starting the engine, read the CATERPILLAR OPERATION GUIDE carefully. Follow the engine starting, operating and maintenance procedures in that manual.
2. The diesel engine should not be started if the temperature of the hydraulic oil is below 0°F (-18°C). If ambient temperatures below 0°F (-18°C) are anticipated, an immersion heater for the hydraulic oil is available. Consult J&M for details.
3. Turn the MAIN POWER switch on the control panel to on.
4. Pull out the ENGINE THROTTLE about half way. Pressing the button on the end of the throttle allows rapid throttle adjustment. Turning the throttle allows fine adjustment. Be sure the EMERGENCY STOP knob is fully pushed in.
5. Press and hold the SHUTDOWN RESET. Turn the ENGINE START switch to START. Hold SHUTDOWN RESET in until engine oil pressure exceeds 30 PSI (2 BAR).
6. Adjust the throttle until the engine is running at 1500 RPM and allow engine to warm up for five minutes. After the engine is warmed up, adjust throttle so engine runs at 2100 RPM's under no load. The engine should hold 1900 RPM's under load.
7. Allow the temperature of the hydraulic oil to come up to at least 30°F (-1°C) before starting the vibrator.

D. WARMING HYDRAULIC OIL

1. The vibrator should not be operated at full speed if the temperature of the hydraulic oil is below 60°F (16°C).
2. If temperature is below 60°F (16°C), set the engine at 1500 RPM and press the START button on the control pendant to start the vibrator. Allow the vibrator to run until the temperature of the hydraulic oil exceeds 60°F (16°C).



MODEL 66-80
VIBRATORY
DRIVER/EXTRACTOR

OPERATING INSTRUCTIONS

III. OPERATING INSTRUCTIONS

D. WARMING HYDRAULIC OIL (CONTINUED)

3. When the engine is warmed up and hydraulic oil temperature is at least 60°F (16°C), full speed operation may begin.
4. The hydraulic oil temperature should be monitored with the Hydraulic Temperature Oil Switch Gage. Oil temperature should never exceed 160°F (71°C). The engine will automatically shut down if oil temperature exceeds 160°F (71°C).

CAUTION: Do not operate the vibrator if hydraulic oil temperature exceeds 160°F (71°C) as this may damage hydraulic components.

E. OPERATION OF REMOTE-CONTROL PENDANT

1. The operation of the vibratory driver is controlled by the remote-control pendant. The pendant is connected to the control cabinet with 50 feet (15m) of electrical cable to permit operation from any advantageous position near the vibrator.
2. The pendant has an Emergency Stop palm button, two control buttons, one with an indicator light, and two switches.

a. To Clamp to Pile:

Position vibratory driver on pile. Turn the clamp switch on the pendant to CLOSE. The CLAMP light (Start Button) on the pendant will illuminate when the hydraulic clamp has achieved adequate pressure to permit vibration to begin. The light should normally come on in a few seconds.

b. To Start Vibration:

Press the START button (lighted).

CAUTION: Do not press the START button until the CLAMP light comes on indicating adequate clamping pressure.



MODEL 66-80
VIBRATORY
DRIVER/EXTRACTOR

OPERATING INSTRUCTIONS

III. OPERATING INSTRUCTIONS

E. OPERATION OF REMOTE-CONTROL PENDANT (CONTINUED)

c. To Stop Vibration:

Press the STOP button.

The vibrator will stop vibration in a few seconds. If the STOP button does not stop the vibrator, pressing the Emergency Stop button will shut down the Power Unit and the vibrator will stop.

d. To unclamp from pile.

Turn the CLAMP switch to OPEN to release the hydraulic clamp so that the vibrator can be removed from the pile. Hold the CLAMP switch in the OPEN position for approximately 10 seconds or until a visual check shows the jaws to be fully open. An electrical interlock prevents the jaw from opening if the Stop button has not been pressed.

CAUTION: Do not turn the switch to OPEN until a visual check indicates that vibration has stopped.

e. Remote Electric Throttle

Momentarily turning the electric throttle switch to the FAST position will increase engine speed (RPM). Turning this switch to the SLOW position will reduce engine speed.

f. Emergency Stop Palm Button

Pressing the EMERGENCY STOP button will stop the diesel engine and all vibrator functions will cease.

g. If the remote- control pendant is damaged or the pendant line is cut, you may still operate the vibrator by using the control switches on the control panel. (See Fig. 1 on page III-1 items J, K, L). To activate these switches, find the toggle switch on the bottom of the control panel, labeled "REMOTE-LOCAL". Turn the switch (item U) to LOCAL and the switches on the control panel will be functional, and the remote control pendant will be disabled.

(NOTE: The EMERGENCY STOP button on the pendant is not disabled during "LOCAL" operation)

h. Radio Remote Control: A Radio frequency Remote Control Unit is available from J&M for the Model 66-80. This unit allows the operator flexibility to control the Vibrator at greater distances from the Power Unit without the inconvenience of the electrical cable. Contact J&M for information and operating instructions.



MODEL 66-80
VIBRATORY
DRIVER/EXTRACTOR

OPERATING INSTRUCTIONS

III. OPERATING INSTRUCTIONS

F. CHANGING FREQUENCY

1. In order to provide maximum flexibility in achieving optimum pile penetration and extraction rates, the frequency of the vibratory driver is adjustable.
2. The frequency can be varied from 800 to 1600 vibrations per minute by changing engine speed. Engine speed is changed with the ENGINE THROTTLE on the control panel or with the remote electric throttle (FAST / SLOW) switch on the pendant. Vibration frequency corresponds approximately to engine speed according to the table shown below.

ENGINE RPM VIBRATOR VPM

2000	1600
1800	1400
1600	1300
1400	1100
1200	900
1000	800

G. SHUT DOWN

1. Stop the vibrator.
2. Allow the diesel engine to run for five minutes at 1100 RPM.
3. Reduce engine speed to idle for about thirty seconds.
4. Stop the engine by turning the ENGINE START switch to OFF.
5. Turn MAIN POWER switch to OFF.
6. Check engine crankcase oil level while power unit is setting level.
7. CAUTION: If the diesel engine is shut down while the vibrator is clamped to a pile, the clamp check valve will keep the vibrator clamped to the pile. However, system leakage could result in a loss of clamp pressure over time. Therefore, it is not recommended to leave the vibrator clamped to a pile when the diesel engine is not running.



MODEL 66-80
VIBRATORY
DRIVER/EXTRACTOR

OPERATING INSTRUCTIONS

IV. MAINTENANCE AND ADJUSTMENTS

A. GENERAL

Preventive maintenance includes normal servicing that will keep the vibratory driver, clamp and power unit in peak operating condition and prevent unnecessary trouble from developing. This servicing consists of periodic lubrication and inspection of the moving parts and accessories of the unit.

Lubrication is an essential part of preventative maintenance, controlling to a great extent the useful life of the unit. Different lubricants are needed and some components in the unit require more frequent lubrication than others. Therefore, it is important that the instructions regarding types of lubricants and frequency of their applications be closely followed.

To prevent minor irregularities from developing into serious conditions that might involve shut-down and major repair, several other services or inspections are recommended for the same intervals as the periodic lubrications. The purpose of these services or inspections is to assure the uninterrupted operation of the unit.

Thoroughly clean all lubrication fittings, caps, filler and level plugs and their surrounding surfaces before servicing. Prevent dirt from entering with lubricants and coolants. The intervals given in the schedule are based on normal operation. Perform these services, inspections, etc., more often as needed for operation under abnormal or severe conditions.

B. DAILY

1. Check the entire unit prior to and during set-up each day or at the beginning of each shift.
2. Prior to starting the power unit or at the beginning of each shift, check the following items:
 - a. Visibly inspect all bolts, nuts and screws including the bolts fastening the hydraulic clamp to the vibration case to insure they are tight. **IMPORTANT:** Vibration loosens bolts. Check carefully.
 - b. Tighten bolts holding gripping jaws in hydraulic clamp.
 - c. Grease plunger in hydraulic clamp with any good multi-purpose grease.
 - d. Check the oil level in the vibration case and add oil if required. The oil level should be in the middle of the sight glass. Change oil if milky or contaminated. DO NOT OVERFILL
 - e. Check the oil level in the hydraulic reservoir and refill if necessary.

CAUTION: It is absolutely imperative that no dirt or other impurities be permitted to contaminate the hydraulic oil. Any contamination will drastically shorten the life of the high-pressure hydraulic system.



MODEL 66-80
VIBRATORY
DRIVER/EXTRACTOR

OPERATING INSTRUCTIONS

IV. MAINTENANCE AND ADJUSTMENTS

B. DAILY (CONTINUED)

- f. Visually check all hoses for signs of damage or cuts that might cause hose failure during operation. Be sure all connections are tight, especially the quick-disconnect couplers.
- g. Visually inspect all suppressor elastomers.
- h. Electrical components need no maintenance except periodic wiping with a clean, dry, lint-free cloth to remove dust.
- i. Perform all daily (10 Service Meter Units) maintenance checks and lubrication in the CATERPILLAR OPERATION GUIDE. For the J&M Model 950 power unit, the HOUR METER on the control panel may be considered to read Caterpillar's "Service Meter Units".

3. After engine start-up, check the following:

- a. Check all hydraulic hoses for leaks. Make sure they hang freely with no kinks.
- b. Check all 5 pumps and all hydraulic manifolds for leaks.
- c. Check the filter indicators. The filter indicators on the power unit must be checked with the diesel engine running at full speed.

C. 125 HOURS (125 Service Meter Units)

1. Every 125 hours drain and refill the vibration case with new lubricant.
2. Perform all maintenance checks and lubrication indicated in the Caterpillar OPERATION GUIDE.
3. After the first 100 hours, drain and replace the lubricant in the multi-pump drive, thereafter change every six months or 2000 hours, which ever comes first.

D. 250, 500 HOURS and Other

1. See Caterpillar OPERATION GUIDE.

E. ANNUALLY

1. Have the hydraulic oil tested by a local hydraulic service center. Replace if required.
2. See Caterpillar OPERATION GUIDE.



MODEL 66-80
VIBRATORY
DRIVER/EXTRACTOR

OPERATING INSTRUCTIONS

IV. MAINTENANCE AND ADJUSTMENTS

F. SEVERE CONDITIONS

1. The service intervals specified are based on normal operating conditions. Operation under unusual conditions require some adjustments in servicing intervals.
2. When the average temperature is above 80°F (26°C) or below -10°F (-23°C), reduce service intervals to one half of those specified in Sections C through E.
3. When operating in the presence of dust or sand, reduce service time intervals by one-half of those specified.
4. When operating in excess of twelve hours per day, reduce service time intervals by one-half of those specified.
5. When operating in air with high salt or moisture, the servicing intervals need not usually be changed. However, the unit should be inspected weekly to determine if additional servicing be required. Also, have hydraulic oil tested quarterly.
6. During stand-by or inactive period, the servicing intervals may be twice those specified above. The unit should be exercised every week. Also, refer to the Caterpillar OPERATION GUIDE.



MODEL 66-80
VIBRATORY
DRIVER/EXTRACTOR

OPERATING INSTRUCTIONS

IV. MAINTENANCE AND ADJUSTMENTS

G. LUBRICATION

1. Crankcase (Diesel Engine)

- a. Follow the engine manufacturer's maintenance schedule and the lubricating oil specifications outlined in the CATERPILLAR OPERATION GUIDE.
- b. The lubricant shall meet the performance requirements of API Service Classifications CD or MIL-L-2104C.
- c. New engines are shipped with ASHLAND 400M+HDT 15W-40 and the following multi-grade crankcase oils are recommended for use or replacement in normal operation (10°F to 90°F) (-12°C to 32°C).

AMOCO	15W-40	300
ARCO	15W-40	Fleet S3 Plus
BORON (BP)	15W-40	Vanellus C Extra
CHEVRON	15W-40	Delo 400
CITGO	15W-40	C500 Plus
CONOCO	15W-40	Fleet Supreme
EXXON	15W-40	XD3
GULF	15W-40	Super Duty Plus
MOBIL	15W-40	Delvac Super
PHILLIPS	15W-40	Super HD II
SHELL	15W-40	Rotella T
SUN	15W-40	Sunfleet Super C
TEXACO	15W-40	Ursa Super Plus
UNION	15W-40	Guardol
VALVOLINE	15W-40	All Fleet

- d. For operation in cold weather climate, refer to the CATERPILLAR OPERATION GUIDE Crankcase Lubricating Oils or contact the nearest Caterpillar representative. For Cold Weather Recommendations (CAT bulletin #SEBU5898-06)

2. Vibration Case

The oil level is easily read through the sight glass located at the lower center of the vibration case opposite the motor side. The proper level is to the middle of the sight gage. DO NOT OVER FILL Lubricating oil may be added when necessary through either of the holes in the vibration case top plate after removing the 1" pipe plugs. To drain the case, remove a 3/4" pipe plug at either end of the base plate. Tilt the case for complete drainage.



MODEL 66-80
VIBRATORY
DRIVER/EXTRACTOR

OPERATING INSTRUCTIONS

IV. MAINTENANCE AND ADJUSTMENTS

G. LUBRICATION (CONTINUED)

3. Multi-Pump Drive Adapter

The oil level is easily checked by looking at the sight gage in the center near the bottom of the multi-pump drive adapter. Lubricating oil should be half way up the sight gage. If low, lubricating oil may be added by removing the breather located on the right side of the Multi-pump Drive Adapter. Draining the lubricating oil may be done by removing the 9/16 socket head pipe plug on the bottom of the Multi-pump Drive Adapter.

4. The preferred lubricating oil for J&M vibration cases and multi-pump drive adapters is a "High Moly Oil" (Schaeffer 268). Longer intervals between oil changes and fewer maintenance hours spent on mechanical service can generally be realized with this oil.

Therefore, whenever the "first preferred" oil is not available or desired, and an alternate oil is selected, it will be necessary to test and/or change the oil at shorter intervals.

Extensive tests have indicated that the use of Schaeffer 268 results in cooler operation and extended bearing and gear life.

The vibration case and multi-pump drive adapter lubricant installed at the factory is SCHAEFFER 268 but the following gear lubes may be used when changing lubricants:

FIRST Preference Group :
SCHAEFFER268

SECOND Preference Group:
MOBILSHC-634
BORONGearep 140
CHEVRONGear Comp. NL460
CITGO Premium MP 85W-140
CITGO Standard MP 85W-140
GULFLub 85W-140 Lub 85W-140
PHILLIPSSMP 85W-140
SHELLOmala 460 Omala 460
SUNSunep 1110



MODEL 66-80
VIBRATORY
DRIVER/EXTRACTOR

OPERATING INSTRUCTIONS

IV. MAINTENANCE AND ADJUSTMENTS

G. LUBRICATION (CONTINUED)

THIRD Preference Group (Natural Petroleum Base):

AMOCOPerma Gear EP140
ARCOPennant NL 460
CONOCOEP 460
EXXON Spartan EP 460
PHILLIPSAP 140
TEXACOMeropa 460
UNIONMP 85W-140
VALVOLINE Gear Lub 85W-140

SCHAEFFER 268 Lubricant is available from J&M in five gallon cans.
See SECTION VIII - ORDERING PARTS, page VIII-48.

5. Hydraulic System

To maintain the maximum operating efficiency in the precision parts of the hydraulic system, it is extremely important to eliminate factors which can cause breakdowns or unsatisfactory performance in the system. Among the most common of these factors are rust, corrosion, contamination and the products of oil deterioration. Most problems can be minimized or avoided simply by maintaining a disciplined preventive maintenance program.

Some simple steps to follow as part of that program are:

- a. Keep stored oil dry and clean at all times and always store in clean containers.
- b. Always clean tools, spouts, lids, funnels, etc. when used in conjunction with the transfer of oil.
- c. Never put dirty oil into the hydraulic system. Use only clean, uncontaminated oil of the types recommended below. Never return to the system any oil which has leaked out.

NOTE: Foreign material in the hydraulic system can drastically effect the life and operation of many hydraulic component parts.

- d. Clean or replace filter elements at the first indication that they are dirty or ineffective.

Mixing of different manufacturers' hydraulic oil is not recommended. However, it can be done if the oils are miscible (contain the same base stock and additives). It may be necessary to contact an oil supplier to determine this.



MODEL 66-80
VIBRATORY
DRIVER/EXTRACTOR

OPERATING INSTRUCTIONS

IV. MAINTENANCE AND ADJUSTMENTS

G. LUBRICATION (CONTINUED)

New power units are shipped with CHEVRON Clarity AW46 hydraulic oil. This oil exceeds the requirements of both the E.P.A. and U.S. Fish and Wildlife Service for non-toxicity and is inherently biodegradable. Adding any other oil from the list that follows, will contaminate the Clarity oil and the system will no longer be environmentally friendly.

Should the customer choose to use an alternate oil, the following recommendations may be used when replacing oil in the hydraulic system. (See page IV-6)

FIRST Preference Group:
CHEVRON Clarity AW46
MOBIL DTE-15
SUN 2105

SECOND Preference Group:
ARCO Duro AW46
CHEVRON Hydraulic AW46
PHILLIPS Magnus A46
SHELL Tellus 46

THIRD Preference Group:
BORON Energol HLP46
CITGO All-Temp HD
CONOCO Super 46
EXXON Nuto H46
GULF Harmony 46AW
SUN Sunvis 805 MG
TEXACO Rando HD AZ46
UNION Unax AW46

Whenever oils from the second preference group are used, it is necessary to test the oil more often to insure that viscosity remains within recommended limits while in service. Using oils from the third preference group requires even a more discerning inspection than use of oils from the second group. Third Group oils may be used when temperature variations are less than those listed below.

The recommended oils were chosen based on the hydraulic system operating temperature range being 5°F (-15°C) (cold ambient start-up) to 160°F (71°C) (maximum operating).



MODEL 66-80
VIBRATORY
DRIVER/EXTRACTOR

OPERATING INSTRUCTIONS

IV. MAINTENANCE AND ADJUSTMENTS

G. LUBRICATION (CONTINUED)

When operating in arctic conditions, it is recommended to use an immersion heater to pre-heat the oil prior to starting. Contact J&M for other arctic operating procedures. It may also be necessary in extremely cold or hot climates to use a different viscosity oil which is better adapted to adverse conditions. Contact the nearest oil supply representative for suggested procedures.

CHEVRON Clarity AW46 hydraulic oil is available from J&M in five gallon cans. See SECTION VIII - ORDERING PARTS, page VIII-48.

H. DRAINING AND FILLING HYDRAULIC OIL RESERVOIR

1. The Hydraulic reservoir is drained by removing a plug on the bottom of the reservoir.
2. The hydraulic reservoir is filled by the manual pump mounted on the back (engine side) of the reservoir. All oil is pumped to the reservoir through the return filter (F2) to insure no dirt enters the hydraulic system.



MODEL 66-80
VIBRATORY
DRIVER/EXTRACTOR

OPERATING INSTRUCTIONS

IV. MAINTENANCE AND ADJUSTMENTS

I. CHANGING HYDRAULIC RETURN FILTER ELEMENT

1. The 2 return filters are located in the hydraulic reservoir above the manual hand pump.
2. To remove filter elements, remove the 4 hex head screws and remove the cover assembly. Screw driver slots are provided at bottom to aid in removing the cover. (Note: Approximately 1 gallon (3.8L) of oil will be lost per filter.)
3. Remove the bypass valve and spring assembly from filter housing. Remove the element.
4. Clean filter housing interior and all component parts with a lint-free rag.
5. Check O-ring for damage. Lubricate with multi-purpose grease.
6. Install new filter element (P/N 140403).
7. Replace bypass valve and spring assembly.
8. Replace cover and tighten 4 hex head screws.
9. Repeat for second filter.
10. Start power unit and run for approximately five minutes. Stop power unit and check for leaks.



**MODEL 66-80
VIBRATORY
DRIVER/EXTRACTOR**

OPERATING INSTRUCTIONS

IV. MAINTENANCE AND ADJUSTMENTS

K. BOLT TORQUE INFORMATION

The only way to actually tighten high strength bolts is with a torque wrench. Proper use of the torque wrench is important. To obtain the listed torques, a steady pull should be exerted to the handle until the desired torque is reached.

The following torque specifications apply to the bolts from the component assemblies listed. Whenever any of these bolts, are replaced, the given torque specifications should be adhered to.

VIBRATION SUPPRESSOR Page VIII-6

Item 8	3/8"-16	48 Ft-Lbs (6.6 Kg-M)
Item 17, 29, 36, 53	1/2"-13	119 Ft-Lbs (16.4 Kg-M)
Item 14	5/8"-11	233 Ft-Lbs (32.2 Kg-M)
Item 12, 43, 44	3/4"-10	417 Ft-Lbs (57.6 Kg-M)
Item 38, 40	1"-8	1009 Ft-Lbs (139.4 Kg-M)

VIBRATION CASE Page VIII-10

Item 16	1/2"-13	119 Ft-Lbs (16.4 Kg-M)
Item 17	3/4"-10	417 Ft-Lbs (57.6 Kg-M)

CLAMP BODY Page VIII-38

Item 15, 19, 29	1"-8	1009 Ft-Lbs (139.4 Kg-M)
Item 4, 26	1-1/2"-6	2800 Ft-Lbs (387 Kg-M)



MODEL 66-80
VIBRATORY
DRIVER/EXTRACTOR

OPERATING INSTRUCTIONS

V. HYDRAULIC CIRCUITRY (REFERENCE: HYDRAULIC SCHEMATIC PG V-4)

A. HYDRAULIC CLAMP

With the diesel engine running, hydraulic oil is taken from the reservoir by the clamp pump (P2). The clamp pump flow returns to the reservoir if the clamp switch on the pendant has not been moved.

Turning the clamp switch on the control pendant to CLOSE activates the CLAMP CONTROL VALVE (V1). Hydraulic oil is directed to the CLOSE CLAMP side of the hydraulic CYLINDER (CYL) in the hydraulic clamp. The clamp closes. Clamping pressure is indicated by the Clamp Pressure Gage (GA-3). When clamping pressure reaches approximately 5500 PSI (379 Bar), the CLAMP PRESSURE SWITCH (PS-1) deactivates the CLAMP CONTROL VALVE (V1), which directs the flow from the clamp pump to the reservoir. Pressure at the clamp is maintained by the CLAMP CHECK VALVE (CV5). If clamping pressure falls below 5000 PSI (345 Bar), the CLAMP PRESSURE SWITCH activates the CLAMP CONTROL VALVE to restore pressure. In the event of hose failure, a second clamp check valve (CV7), located in the clamp cylinder, will hold the clamp cylinder closed.

Turning the clamp switch on the control pendant to OPEN activates the CLAMP CONTROL VALVE (V1). Hydraulic oil is directed to the OPEN CLAMP side of the hydraulic cylinder. The pressure in the OPEN CLAMP line opens the CLAMP CHECK VALVES (CV5 & CV7). The clamp opens. Pressure in the OPEN CLAMP line is indicated by the clamp pressure gage (GA-4).

Pressure in the clamping circuit is limited to 5500 PSI (379 Bar) by the CLAMP RELIEF VALVE (RV2). The quick-disconnect couplers (QD3 & QD4) permit decoupling of the clamp hoses at the power unit.

B. VIBRATOR DRIVE

With the diesel engine running, hydraulic oil is taken from the reservoir by the four DRIVE PUMPS (P1). Oil pressure opens the cartridge C2 and vents the hydraulic oil back to the reservoir through the RETURN FILTERS (F2), if the vibrator button (START) has not been pushed.

Pushing the START button, on the control pendant, activates the SOLENOID on the CONTROL VALVE (V2). By blocking the pilot flow from cartridge C2, the CONTROL VALVE (V2) causes this cartridge to close, thus directing pump flow to the VIBRATOR MOTORS (M).



**MODEL 66-80
VIBRATORY
DRIVER/EXTRACTOR**

OPERATING INSTRUCTIONS

V. HYDRAULIC CIRCUITRY

B. VIBRATOR DRIVE (CONTINUED)

Full motor speed is reached within a few seconds and the motor drive pressure is indicated by GAGE (GA1). Maximum drive pressure is limited to approximately 5500 PSI (379 Bar) by the FORWARD RELIEF VALVE (RV1). The RELIEF VALVE (RV1), if opened by over pressure, permits a small pilot flow from cartridge (C2). This pilot flow causes cartridge (C2) to partially open and allows some or all of the pump flow to return to the reservoir. Oil exiting VIBRATOR MOTORS (M) opens cartridge BV and returns to the power unit. Cartridge BV opens easily because its pilot flow is "vented" by BRAKE VALVE (RV5). BRAKE VALVE (RV5) is held open by pressure coming from the motor drive FORWARD system. Case drain oil from the motors returns to the reservoir. Case drain pressure is limited to 65 PSI (4.5 Bar) by the CASE DRAIN RELIEF VALVE (RV3). Oil returning to the power unit returns to the reservoir through COOLER VALVES (V3), HEAT EXCHANGER (HE) and RETURN FILTERS (F2).

Pushing the STOP button on the control pendant, de-energizes the CONTROL VALVE (V2) and "vents" (open) cartridge C2, allowing pump flow to go directly back to the reservoir. When pressure is removed from the drive FORWARD system, the BRAKE VALVE RELIEF (RV5) closes and blocks the pilot flow to BRAKE VALVE (BV) cartridge, causing it to close. Maximum brake pressure generated by BRAKE VALVE (BV) is limited by BRAKE VALVE RELIEF (RV5) TO 2000 PSI (138 Bar). This 2000 PSI (138 Bar) back pressure rapidly brakes the motors (M) to a stop.

Hydraulic oil temperature is regulated by the COOLER VALVES (V3). When oil temperature is below 100°F (38°C), V3 directs the flow directly to the reservoir through FILTER (F2). When oil temperature exceeds 100°F (38°C), COOLER VALVE (V3) directs flow through the HEAT EXCHANGER (HE) before it enters the reservoir, through FILTER (F2). Excessive pressure in the HEAT EXCHANGER (HE) is prevented by CHECK VALVES (CV3 & CV4), which bypasses excess flow and limits pressure to 65 PSI (4.5 Bar).

The quick-disconnect couplers (QD1, QD2, and QD5) permit de-coupling of the drive and case drain hoses at the power unit.



MODEL 66-80
VIBRATORY
DRIVER/EXTRACTOR

OPERATING INSTRUCTIONS

V. HYDRAULIC CIRCUITRY

C. OTHER

Returning oil is filtered by the RETURN FILTER (F2). The return FILTER CHECK VALVES (CV1 and CV2) prevents oil loss from the reservoir when the filter elements are removed.

A manual PUMP (MP) is provided to fill the hydraulic reservoir. A CHECK VALVE (CV8) prevents loss of returning hydraulic oil back through this pump.

Temperature of the oil in the reservoir is continually sampled by the hydraulic oil Temperature Switch Gage (TS2), which shuts down the diesel engine if the oil temperature exceeds 160°F (71°C).

Motor cavitation is prevented in the braking operation by the CHECK VALVE (CV6).

The (ACC-1) in the pilot system expands as pressure increases. The additional pilot flow causes cartridge (C2) to produce a smooth acceleration of the VIBRATOR MOTORS (M).



MODEL 66-80
VIBRATORY
DRIVER/EXTRACTOR

OPERATING INSTRUCTIONS

V. HYDRAULIC CIRCUITRY

HYDRAULIC SCHEMATIC

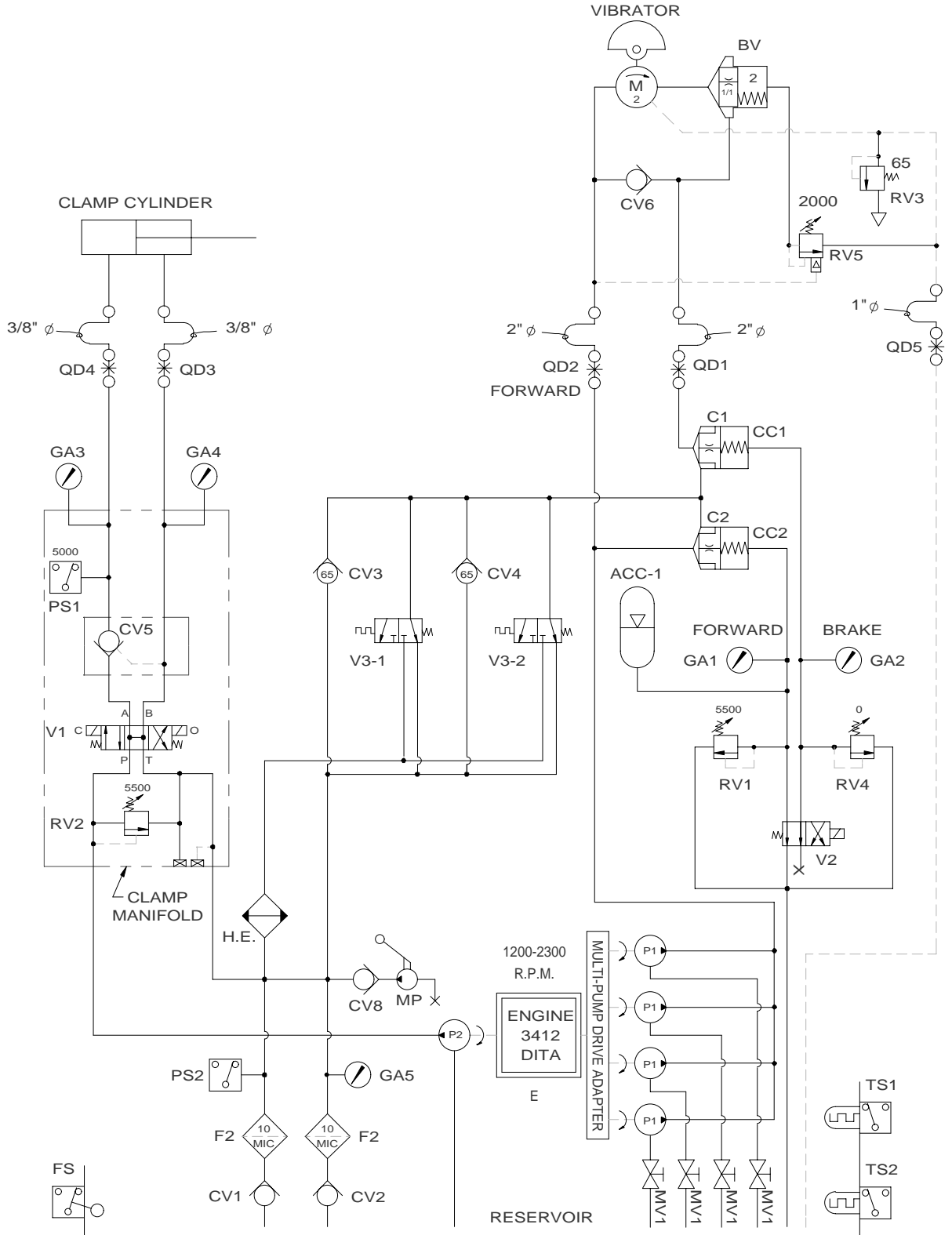



MODEL 66-80
VIBRATORY
DRIVER/EXTRACTOR

OPERATING INSTRUCTIONS

V. HYDRAULIC CIRCUITRY

D. HYDRAULIC COMPONENTS LIST

<u>Notation</u>	<u>Description</u>	<u>Part Number</u>	<u>Page Number</u>
ACC-1	Accumulator	810295	VIII-31
BV	Brake Valve Cartridge	110622	VIII-13
C1	Cartridge Valve	140669	VIII-35
C2	Cartridge Valve	140669	VIII-35
CC1	Cartridge Cover	140671	VIII-35
CC2	Cartridge Cover	140671	VIII-35
CV3 & 4	Check Valve -Bypass	130339	VIII-35
CV5	Clamp Check Valve	110149	VIII-37
CV6	Check Valve - Vibrator	110296	VIII-13
CV7	Check Valve - Clamp Cylinder	120629	VIII-39
CV8	Manual Pump Check Valve	100451	VIII-27
CYL	Hydraulic Clamp Cylinder		
E	Diesel Engine	140687	VIII-26
F2	Return Filter (2)	140179	VIII-27
	CV1 & 2 Return Filter Check Valve		
FS	Float Switch	100314	VIII-28
GA1-4	Pressure Gage	110600	VIII-29
GA5	Filter Indicator Gage	100775	VIII-27
HE	Heat Exchange	140763	VIII-31
M	Motor (2)	140679	VIII-11
MP	Manual Pump	100447	VIII-27
MV	Manual Valve	400117	VIII-28
P1	Drive Pump (4)	140829	VIII-26
P2	Clamp Pump	140839	VIII-29
PS1	Clamp Pressure Switch	810425	VIII-37
PS2	Return Filter Pressure Switch	140413	VIII-27
QD1	Vibrator Reverse Disconnect	140037	VIII-28
QD2	Vibrator Forward Disconnect	140035	VIII-28
QD3	Clamp Open Disconnect	100777	VIII-28
QD4	Clamp Close Disconnect	100245	VIII-28
QD5	Case Drain Disconnect	120025	VIII-28
RV1	Forward Relief Valve	140677	VIII-30
RV2	Clamp Relief Valve	100898	VIII-37
RV3	Case Drain Relief Valve	110214	VIII-13
RV4	Brake Valve Relief (P U)	140677	VIII-30
RV5	Brake Valve Relief (Vibro)	110242	VIII-13
TS1	Temperature Switch	110590	VIII-29
TS2	Temperature Switch	110640	VIII-19
V1	Clamp Control Valve	110147	VIII-37
V2	Control Valve	140665	VIII-30
V3	Cooler Valve (2)	110628	VIII-35



MODEL 66-80
VIBRATORY
DRIVER/EXTRACTOR

OPERATING INSTRUCTIONS

VI. ELECTRIC CIRCUITRY (Reference:Electrical Schematic Pg VI-5)

A. STARTING DIESEL ENGINE

The engine batteries (EB1, EB2) provide 24-volt current to start the diesel engine. With the MAIN POWER (CB2) switch on, and holding the SHUTDOWN RESET button in. Turning the ENGINE START switch to START energizes the start motor solenoid (SOL) and turns over the diesel engine. If fuel is available, the diesel engine will start.

B. STOPPING DIESEL ENGINE

Turning the ENGINE START switch to OFF de-energizes the fuel pump RACK SOLENOID, by de-energizing fuel relay (R3), which shuts off the fuel supply to the diesel engine. The engine stops.

C. SAFETY CONTROL SYSTEM

A system of safety controls shut off the fuel supply, thereby stopping the diesel engine in the event that any one of six malfunctions occur. The heart of the safety system is the SHUTDOWN RESET which is closed during normal operations (button in), thereby providing current to the fuel relay (R3). With the fuel relay energized, a set of contacts (R3A) close, energizing the RACK SOLENOID and turning on the fuel supply. With the SHUTDOWN RESET closed (button in) power is provided to the vibrator start circuitry.

As mentioned above, the SHUTDOWN RESET is closed during normal operation. If the SHUTDOWN RESET is opened, the fuel relay (R3) is de-energized, contacts RA3 open, resulting in the RACK SOLENOID being de-energized thereby shutting off the fuel supply and stopping the diesel engine. The SHUTDOWN RESET opens when its timing delay coil (TD,C), or it's "instant trip" coil (C), is energized. The timing delay or instant trip coil may be energized by any of the following devices.

1. Engine Oil Pressure Gage - if pressure is below 10 PSI (.7 Bar), the contacts of the gage will be closed providing current to energize the instant trip coil (C) and to turn on the indicator light (L1). On start-up, the button on the SHUTDOWN RESET (on the control panel) must be held in until the oil pressure exceeds 30 PSI (2 Bar).
2. ENGINE WATER TEMPERATURE GAGE - If water temperature exceeds 210° F (99°C), the contacts of the gage will close energizing the timing delay coil (TD,C) and turning on the indicator light (L2).
3. Engine Overspeed Switch - if the engine overspeeds, the overspeed switch will close, energizing the instant trip coil (C) and turning on indicator light (L3).



MODEL 66-80
VIBRATORY
DRIVER/EXTRACTOR

OPERATING INSTRUCTIONS

VI. ELECTRICAL CIRCUITRY

C. SAFETY CONTROL SYSTEM (CONTINUED)

4. Return Filter Switch - if the hydraulic return filter is clogged, the return filter switch (PS3) will close energizing the timing delay coil (TD,C) and turning on the indicator light (L4). The Return Filter Shutdown is disabled if Temperature Switch Contacts (TS1) are opened by oil temperature less than 100°F (38°C).
5. Hydraulic Oil Level Switch - if the hydraulic oil level is low, the hydraulic oil switch will close energizing the timing delay coil (TD,C) and turning on indicator light (L5).
6. Hydraulic Oil Temperature Gage - if the temperature of the hydraulic oil exceeds 160°F (71°C), the hydraulic oil temperature gage switch will close, energizing the timing delay coil (TD,C) and turning on indicator (L6).

A diode (D1-D6) on each malfunction switch limits the flow of direct current to prevent multiple lights coming on. Another diode (D8) prevents arcing in the malfunction switches.

Emergency Stop - When the diesel engine is running, pressing the EMERGENCY STOP button on the pendant, energize the coil on the SHUTDOWN RESET. The Shutdown Reset opens and the engine and vibrator are stopped.

D. CLOSING HYDRAULIC CLAMP

With the diesel engine running, turning the clamp switch (OPEN-CLOSE) on the control pendant to CLOSE energizes the close-clamp solenoid (CLOSE-SOL.). This operates the clamp control hydraulic valve and closes the clamp.

When the pressure in the close-clamp hydraulic circuit reaches 5500 PSI (379 Bar), the pressure switch (PS1) opens and de-energizes the CLOSE-CLAMP solenoid and turns on the CLAMP LIGHTS on the control pendant and control panel. If close-clamp pressure falls below 5000 PSI (345 Bar), the pressure switch closes and re-energizes the close-clamp solenoid to rebuild pressure. The CLAMP LIGHTS go out. When pressure returns to 5500 PSI (379 Bar), the pressure switch opens de-energizing the close-clamp solenoid and turns on the CLAMP LIGHTS.

E. OPENING HYDRAULIC CLAMP

With the diesel engine running, turning the clamp switch (OPEN-CLOSE) to OPEN energizes the open-clamp solenoid (OPEN SOL.). The clamp opens. Normally Closed Contacts (R1C) in the Start Relay (R1), prevent the operator from opening the clamp while the vibrator is running.



MODEL 66-80
VIBRATORY
DRIVER/EXTRACTOR

OPERATING INSTRUCTIONS

VI. ELECTRICAL CIRCUITRY

F. STARTING THE VIBRATOR

With the diesel engine running, pressing the START button on the control pendant energizes the start relay coil (R1). Start relay contacts (R1-A) close and keep the relay coil energized until the STOP button is depressed. A second set of start relay contacts (R1-B) close and energizes the FORWARD SOLENOID on the Control Valve. The Control Valve sends hydraulic oil to the vibrator motors. The motors start. A third set of contacts (R1-C) opens to prevent the OPEN SOLENOID being energized to open the hydraulic clamp while the vibrator is running.

G. STOPPING THE VIBRATOR

With the diesel engine running, pressing the STOP button on the control pendant de-energizes the start relay coil (R1). The start relay contacts (R1-B) open and de-energize the FORWARD SOLENOID. The Control Valve stops the flow of hydraulic oil to the vibrator motors. The motors stop. The start relay contacts (R1-C) close to allow the OPEN SOLENOID to be energized when the OPEN clamp button is turned to the OPEN position.

H. OTHER

The ammeter (AM) indicates charging amperes. The tachometer generator (TACH GEN) powers the tachometer (TACH) to indicate engine speed. The Hour meter (M1) indicates the engine operating hours.

Duplicate vibrator and clamp switches are located on the control pendant and on the control panel. Turning the LOCAL-REMOTE switch to LOCAL activates only the clamp and vibrator switches located on the control panel. Turning the LOCAL-REMOTE switch to REMOTE only permits operation of the clamp and vibrator from the control pendant. The EMERGENCY STOP button on the pendant is functional at all times.

Turning the Throttle switch to the FAST position will retract the electric throttle actuator (M) and increase engine speed (RPM). Turning the Throttle switch to the SLOW position will extend the electric throttle actuator (M) and decrease engine speed.

Stopping the vibrator may be done by pressing either of the STOP buttons on the Control Panel or the Control Pendant at any time, no matter which position the LOCAL-REMOTE switch is in.



**MODEL 66-80
VIBRATORY
DRIVER/EXTRACTOR**

**OPERATING
INSTRUCTIONS**

VI. ELECTRICAL CIRCUITRY

ELECTRICAL LAYOUT

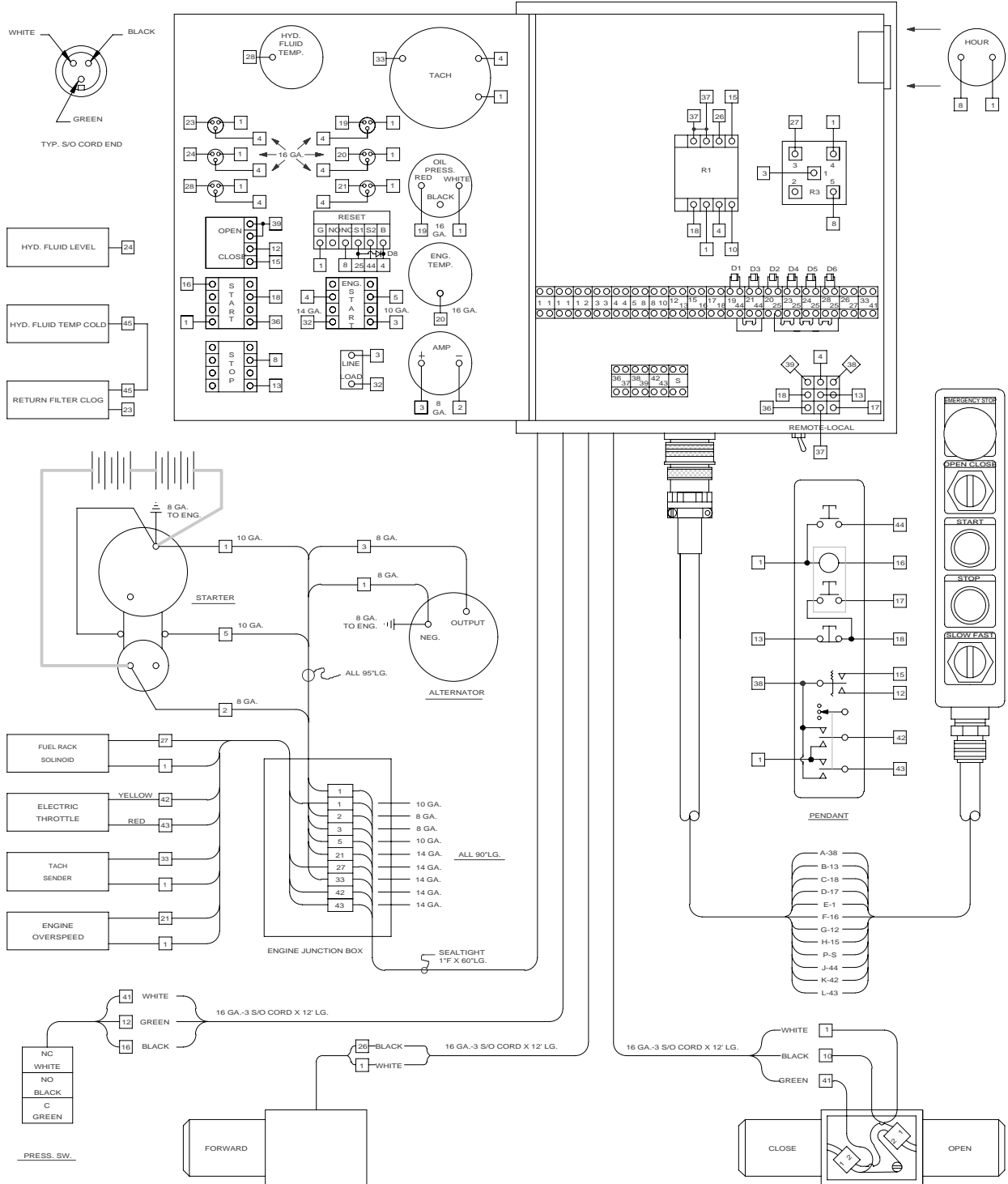



MODEL 66-80
VIBRATORY
DRIVER/EXTRACTOR

OPERATING INSTRUCTIONS

VI. ELECTRICAL CIRCUITRY

ELECTRICAL SCHEMATIC

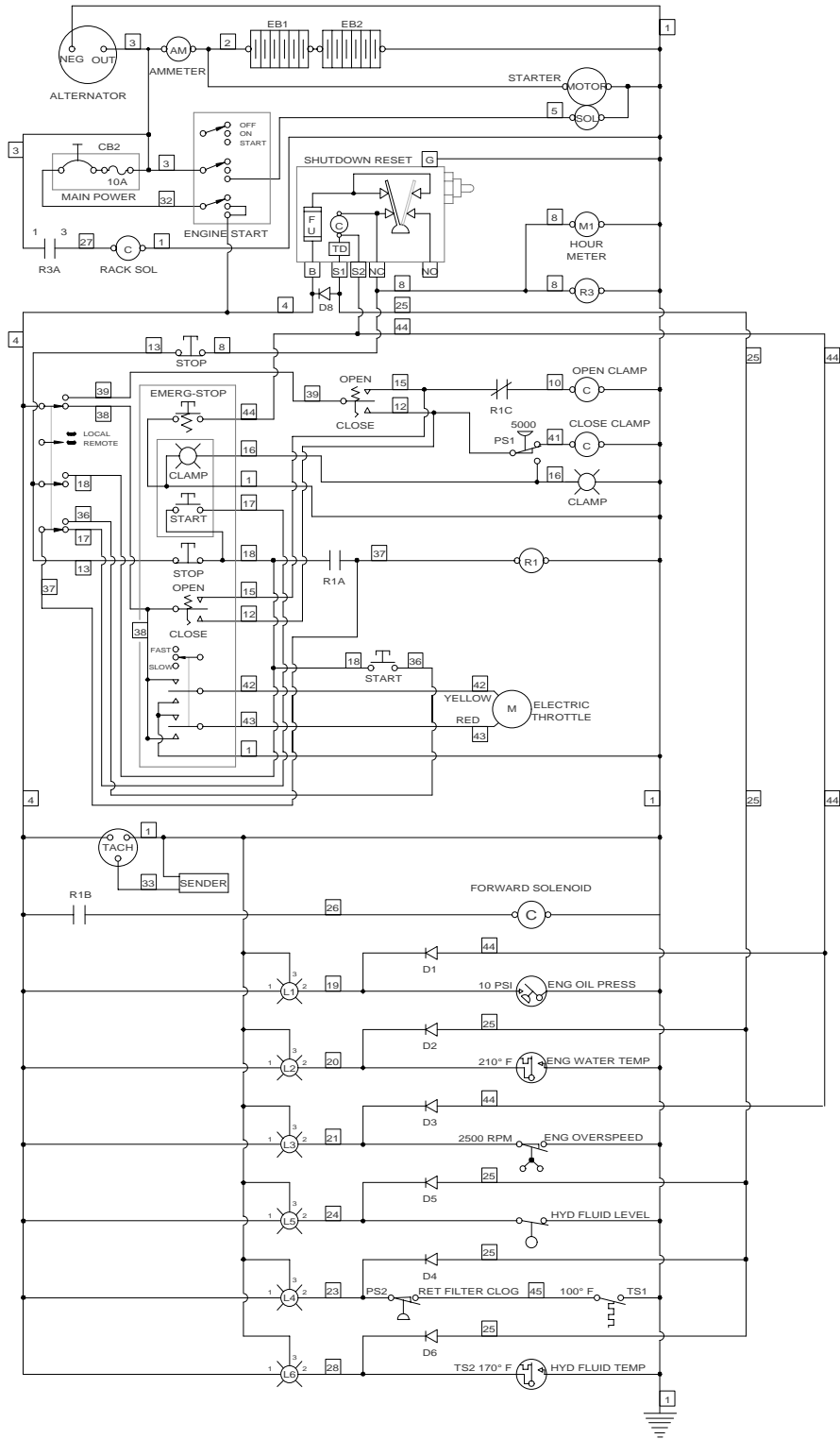



MODEL 66-80
VIBRATORY
DRIVER/EXTRACTOR

OPERATING INSTRUCTIONS

VI. ELECTRICAL CIRCUITRY

I. ELECTRICAL COMPONENTS LIST

<u>Notation</u>	<u>Reference</u>	<u>Part Number</u>	<u>Page Ref.</u>
ALTERNATOR	Alternator	See Cat. Parts Book	
AMMETER	Ammeter	110371	VIII-19
CB2	Main Power Switch	400141	VIII-19
CLAMP LIGHT (2)	Clamp Light	110598	VIII-19 & 23
CLOSE SOL	Close-Clamp Solenoid	110147	VIII-37
D1-D6, D8	Diode	100413	VIII-19
EB1 , EB2	Engine Battery	100529	VIII-29
EMERG-STOP	Emergency Stop Switch	130507	VIII-23
ENG. OIL PRESS.	Engine Oil Pressure Gage And Switch	100329	VIII-19
ENG. START	Engine Start Switch	110615	VIII-19
ENG. WATER TEMP.	Engine Water Temperature Gage And Switch	110697	VIII-19
ENG. OVERSPEED	Engine Overspeed Shut- Down Switch	110759	VIII-31
FS	Hyd Oil Level Switch	100314	VIII-28
FOR.SOLENOID	Forward Solenoid	140665	VIII-30
HOURMETER (M1)	Hour Meter	100343	VIII-19
L1-L6	Shutdown Indicator Light	100355	VIII-19
M	Electric Throttle	110460	VIII-31
OPEN/CLOSE (2)	Clamp Switch (OPEN/CLOSE)	130155	VIII-19 & 23
OPEN SOL	Open-Close Solenoid	110147	VIII-37
PS1	Pressure Switch	810425	VIII-37
PS2	Return Filter Clogged Switch	140413	VIII-27
R1	Start Relay Coil	110584	VIII-19
R1-A,B,C	Start Relay Contacts	110584	VIII-19
R3	Fuel Relay Coil	110604	VIII-19
R3A	Fuel Relay Contacts	110604	VIII-19
RACK SOL	Fuel Rack Solenoid	See Cat. Parts Book	
REMOTE-LOCAL	Remote-Local Switch	140361	VIII-19
SHUTDOWN RESET	Engine Safety Shutdown	110456	VIII-19
SLOW-FAST	Engine Throttle Switch	100566	VIII-23
START	Start Vibrator Button	110598	VIII-19 & 23
STARTER	Engine Starter Motor	See Cat. Parts Book	
STOP	Stop Vibrator Button	100363	VIII-19 & 23
TACH	Tachometer	110650	VIII-19
SENDER	Engine Tach Pick-Up	100408	VIII-28
TS1	Hyd Oil Temp. Switch	110590	VIII-29
TS2	Hyd Oil Temperature Switch Gage	110640	VIII-19



MODEL 66-80
VIBRATORY
DRIVER/EXTRACTOR

OPERATING INSTRUCTIONS



MODEL 66-80
VIBRATORY
DRIVER/EXTRACTOR

PARTS LIST

VII. GENERAL DATA

A. ABBREVIATIONS

The abbreviations shown below are used throughout the parts lists and various other parts of the manual.

ASM.	Assembly
BHCS	Button Head Cap Screw
Cyl.	Cylinder
DC	Direct Current
FHCS	Flat Head Cap Screw
FLCS	Flanged Head Cap Screw
HC	High Collar
HHCS	Hex Head Cap Screw
HHPP	Hex Head Pipe Plug
HSSS	Hex Socket Set Screw
Hyd.	Hydraulic
Lg	Long
mm	Millimeter
Mtg.	Mounting
NPT.	National Pipe Thread
PHMS	Phillips Head Machine Screw
P/N	Part Number
Qty.	Quantity
RHMS	Round Head Machine Screw
Sch.	Schedule
SHCS	Socket Head Cap Screw
SHPP	Socket Head Pipe Plug
SHSS	Socket Head Shoulder Screw
S/N	Serial Number
Sol.	Solenoid
UNF	Unified National Fine
UNC	Unified National Coarse

B. SCREWS AND BOLTS

1. Practically all connections on the unit are made with socket head (Allen) cap screws. These high-strength screws are available at most industrial supply houses.
2. Screws and bolts are designated in the PARTS LIST in abbreviated form. (Refer to sub-section A, above, for specific abbreviations). Listed below is a typical screw description: .50 - 13 UNC x 1.50 Lg SHCS

.50 = Diameter
13 UNC = Threads Per Inch
1.50 Lg = Length
SHCS = Screw Type Abbreviation



MODEL 66-80
VIBRATORY
DRIVER/EXTRACTOR

PARTS LIST

VII. GENERAL DATA

B. SCREWS AND BOLTS (CONTINUED)

3. Some screws or bolts require a specific torque when replacing. For identification of these bolts and a more thorough understanding of torque, refer to page IV-10.

C. SERIAL NUMBER LOCATIONS

1. The following J&M vibratory units are serial numbered separately:
 - a. Vibrator
 - b. Power unit
 - c. Piling clamps
 - d. Caisson beams
 - e. 90 deg. clamp adapter
2. In addition to the serial number plate itself (on vibrators, power units and clamps), the serial number is stamped into each unit in one or more places as follows:
 - a. Vibrator stamped twice - once on top right side of suppressor housing, once on bottom lip of vibration case on right side of motors' side.
 - b. Power unit stamped twice - once on control panel side of unit at right corner of reservoir, once on sub-base inside door below hex-key rack.
 - c. Model 196 universal clamp is stamped three times - once between the cylinder and pile guide, once above the grease fitting, and once on the flange of the cylinder housing.
 - d. Model 122 caisson clamp stamped twice - once on side of the body at the jaw opening nearest the fixed jaw side, and once on the underside of the body under the pile guide on the cylinder side.
 - e. Caisson beam is stamped three times - once on top center, once in center of both sides of flange.
 - f. 90 deg. clamp plate stamped twice - once on top center, once on side.



MODEL 66-80
VIBRATORY
DRIVER/EXTRACTOR

PARTS LIST

VIII. ORDERING PARTS

A. PROCEDURE

1. When ordering parts, be sure to include the model and serial number of the unit or component. The serial number may be located by referring to SECTION VII, SERIAL NUMBER LOCATION. Confirm all telephone orders in writing immediately to avoid duplicating shipment.
2. ORIGINAL EQUIPMENT; Where component serial numbers are given, these apply only to equipment and components originally furnished with the unit. Where equipment has been changed or upgraded these numbers may not be an adequate description.
3. SHIPMENT; Specify shipping address, phone number, billing address and method of shipment. UPS and air express shipments must have street address for delivery. All shipments will be made freight collect unless instructed otherwise.
4. SHORTAGES; Claims for shortages, damage or errors should be made immediately upon receipt of parts. No responsibility will be assumed for delay, damage or loss of material while in transit. Broken, damaged or lost material should be refused or a full description made of damage or loss to the carrier agent on the freight or express bill.
5. RETURN OF PARTS; If for any reason you desire to return parts to the factory or to any distributor from whom these parts were obtained, you must first secure permission to return the parts. Shipping instructions will be given along with this permission. A fifteen percent handling charge must be assessed against the returned shipment unless an error is made by the factory or by the distributor when filling your order.



**MODEL 66-80
VIBRATORY
DRIVER/EXTRACTOR**

PARTS LIST

VIII. ORDERING PARTS

B. FITTING DESCRIPTION KEY

<p><u>FITT</u> 2</p> <p><u>SELECTOR INDEX</u> 2 - INCH FITTING 9 - METRIC FITTING</p> <p><u>CONFIGURATION OR SHAPE OF FITTING</u> S - STRAIGHT FITTING L - 90 Deg. ELBOW V - 45 Deg. ELBOW T - TEE C - CAP P - PLUG U - UNION X - CROSS (FOURTH END FITT'G REQ'D.)</p> <p><u>FIRST END SIZE</u> * IN 1/16THS OF AN INCH (INDEX 2) IN MILLIMETERS (INDEX 9) SEE GENERAL SPECIFICATION SHEET FOR SEQUENCE OF ORDER</p> <p><u>FIRST END FITTING STYLE</u> SEE FITTING STYLE SELECTOR CHART SC-1</p> <p><u>SECOND END SIZE</u> IF APPLICABLE - SEE FIRST END SIZE</p> <p><u>SECOND END FITTING STYLE</u> IF APPLICABLE - SEE FIRST END FITTING STYLE</p> <p><u>THIRD END SIZE</u> IF APPLICABLE - SEE FIRST END SIZE</p> <p><u>THIRD END FITTING STYLE</u> IF APPLICABLE - SEE FIRST END SIZE</p> <p><u>* EXCEPTIONS</u> 90 = 10" 96 = 6" 92 = 12" 98 = 8" 94 = 14" 99 = NON CODE SIZE</p>	<p>L - 16</p> <p>M 12</p> <p>J 00</p> <p>0 - 00L</p> <p>0 0 0 1</p>	<p><u>MATERIAL</u> 1 - CARBON STEEL 2 - BRASS 4 - STAINLESS STL 5 - AAR MAL IRON 6 - MALEABLE IRON 8 - FORGED STEEL</p> <p><u>SPECIAL NOTATIONS</u></p> <p><u>PRESSURE RATING</u> 0 - NONE 1 - 125 LB. 3 - SCH 40 4 - SCH 80</p> <p><u>INSTALLATION AID OR STYLE OF HEAD</u> 0 - NOT APPLICABLE H - REGULAR HEX Q - SQUARE HEAD (EXT.) R - SQUARE HEAD (INT.) S - HEX HEAD (INT SOCKET) T - HEX HEAD (EXT.)</p> <p><u>LENGTH CODE</u> (ELBOWS & NIPPLES) __L - LONG (ELBOW) __X - EXTRA LONG (ELBOW) __C - CLOSE (NIPPLE)</p> <p>PIPE NIPPLES (LONG) ONLY IN DEC. INCHES FOR INDEX 2 050 = 5.0 INCHES 105 = 10.5 INCHES</p> <p>IN MILLIMETERS FOR INDEX 9 120 = 12.0 MILLIMETERS 084 = 8.4 MILLIMETERS</p> <p><u>FOURTH END SIZE & FITTING STYLE</u> (CROSSES ONLY) SEE FIRST END FITTING SIZE OR END STYLE</p>
---	---	---



**MODEL 66-80
VIBRATORY
DRIVER/EXTRACTOR**

PARTS LIST





VIII. ORDERING PARTS

B. FITTING DESCRIPTION KEY (CONTINUED)

FITTING STYLE SELECTOR CHART

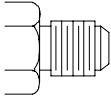
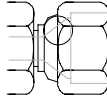
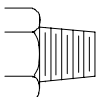
SC-1

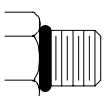
FOR END FITTING STYLE SELECTION

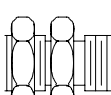
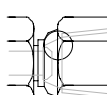
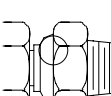
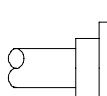
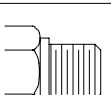
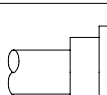
M		JIC MALE 37 Deg. FLARE	J		JIC FEMALE 37 Deg. FLARE (& SWIVEL)
P		MALE PIPE NPT	Q		FEMALE PIPE NPTF
R		S.A.E. MALE O-RING (& ADJUSTABLE)	K		S.A.E. FEMALE O-RING
B		JIC MALE 37 Deg. FLARE BULKHEAD	N		FEMALE PIPE NPSM-SWIVEL
D		MALE PIPE NPT SWIVEL	F		SPLIT FLANGE 3000 PSI. CODE 61
S		B.S.P. MALE PIPE	H		SPLIT FLANGE 6000 PSI. CODE 62



**MODEL 66-80
VIBRATORY
DRIVER/EXTRACTOR**

PARTS LIST

VIII. ORDERING PARTS

C. HOSE DESCRIPTION CODE

The HOSE DESCRIPTION CODE is a 24 digit number enabling easier and quicker identification whenever a hose replacement is desired. The key below explains the structure of the coded number in detail.

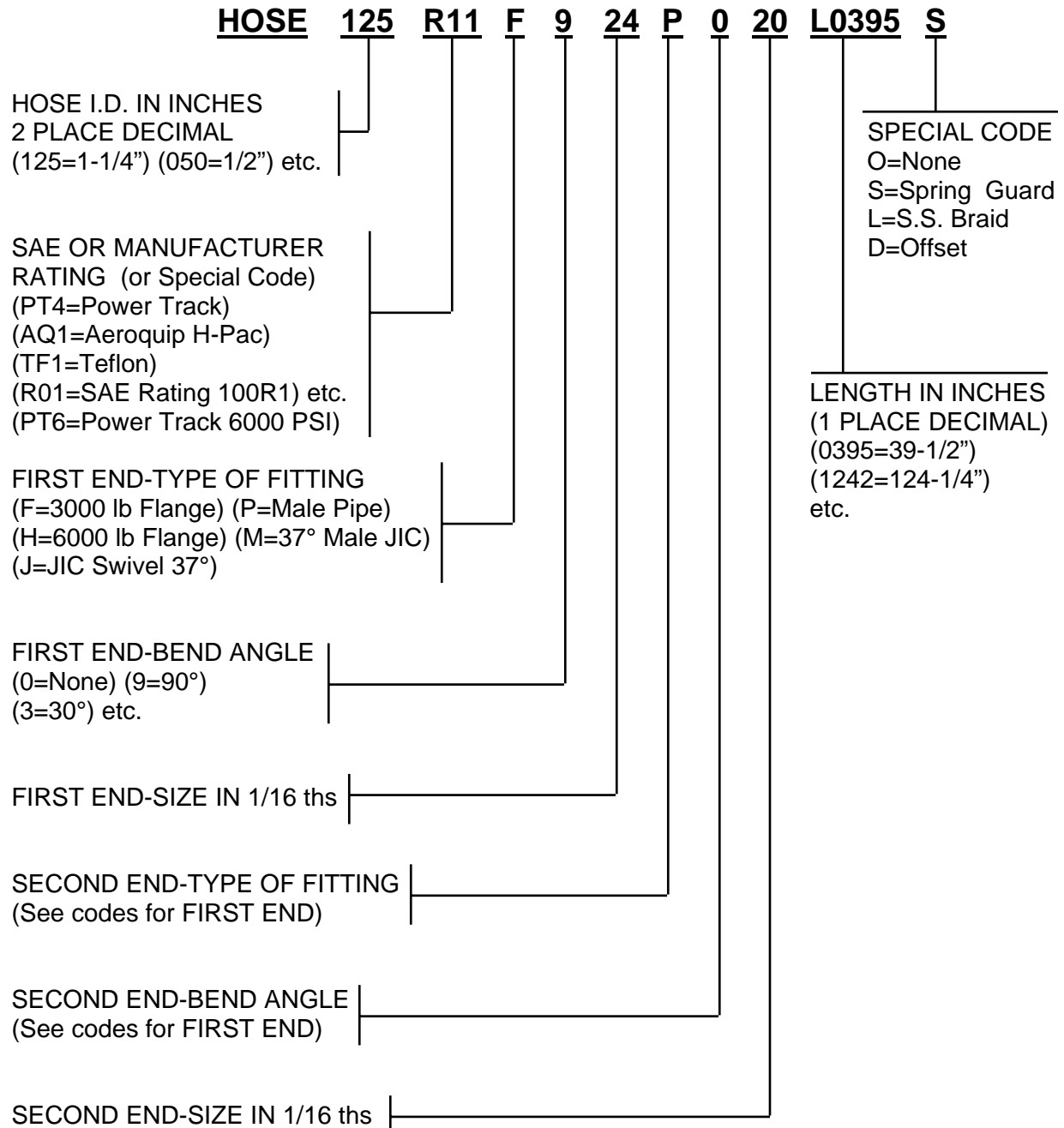



MODEL 66-80
VIBRATORY
DRIVER/EXTRACTOR

PARTS LIST

VIII. ORDERING PARTS

D. PARTS IDENTIFICATION

1. Parts lists and drawings are included on the following pages for the equipment components shown below:

a. VIBRATION SUPPRESSOR	800503	VIII-6
b. VIBRATION CASE	810749	VIII-10
c. DISTRIBUTION BLOCK	810751	VIII-12
d. HOSE ASSEMBLIES-INTERCONNECTING	800405	VIII-14
e. POWER UNIT - ENCLOSURE	810589	VIII-16
f. CONTROL BOX	810593	VIII-18
g. PENDANT ASM	800395	VIII-22
h. POWER UNIT - INTERNAL	800385	VIII-24
i. JUNCTION BOX	810145	VIII-33
j. CONTROL MANIFOLD	810591	VIII-34
k. CLAMP MANIFOLD	810449	VIII-36
l. MODEL 196 UNIVERSAL CLAMP	800315	VIII-38
m. CLAMP EXTENSION-10FT.	800423	VIII-40
n. 90 DEG. ADAPTER	800049	VIII-41
o. CAISSON BEAM-7 FT.	800517	VIII-42
p. CAISSON BEAM-11 FT.	800519	VIII-43
q. MODEL 122 CAISSON CLAMP	800409	VIII-44
r. PENDANT EXTENSION CABLE	800059	VIII-47

2. The spare parts list SECTION VIII - RECOMMENDED SPARE PARTS contains spare parts which may be very useful in keeping down-time to a minimum, especially in remote or secluded job sites where unforeseen communication problems could cause delay of the delivery of an awaited part.

These RECOMMENDED SPARE PARTS may be ordered beforehand, individually or as a package group as shown in the PARTS LIST.



MODEL 66-80
VIBRATORY
DRIVER/EXTRACTOR

PARTS LIST

VIBRATION SUPPRESSOR

800503

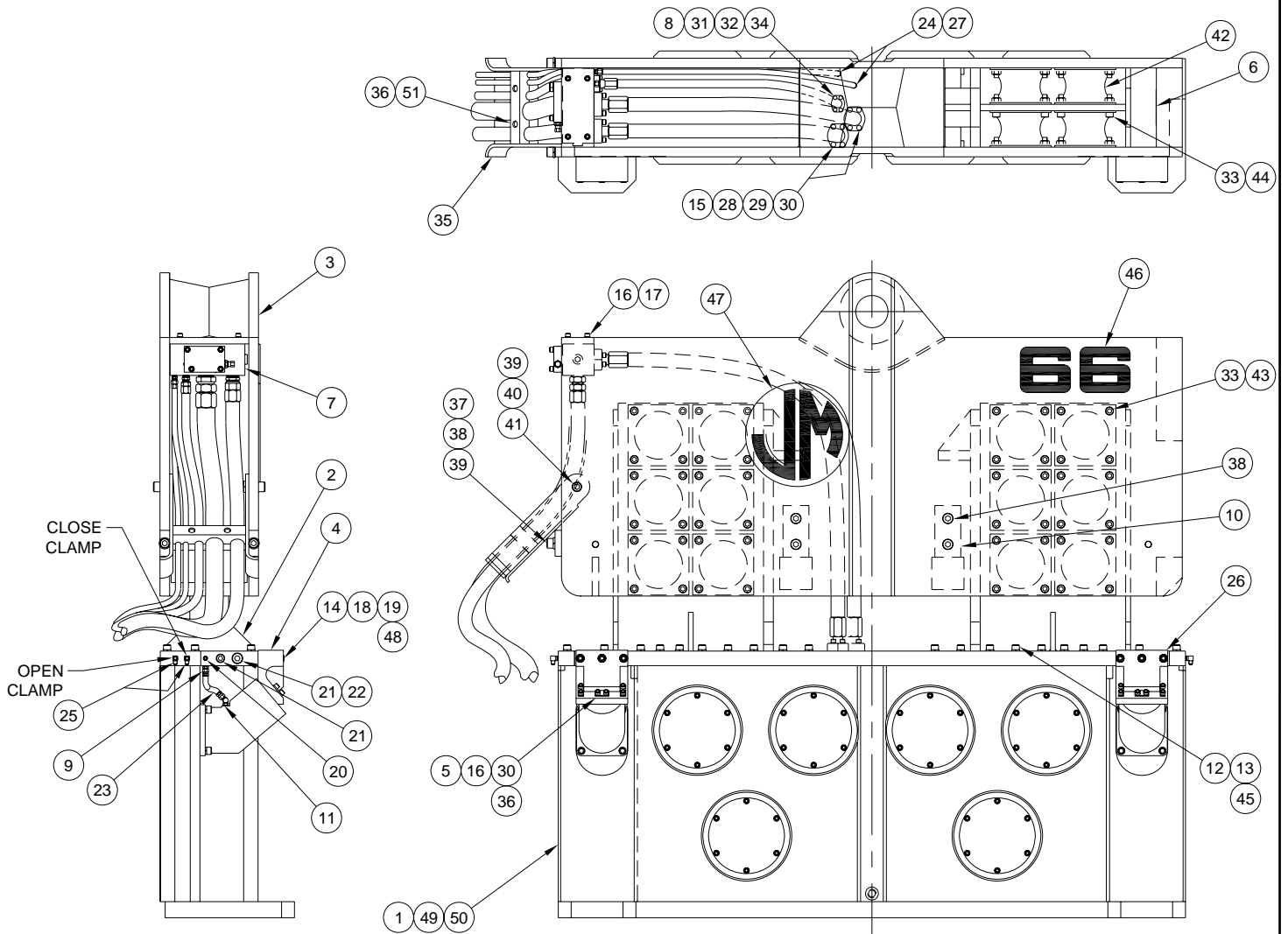



MODEL 66-80
VIBRATORY
DRIVER/EXTRACTOR

PARTS LIST

VIBRATION SUPPRESSOR

800503

<u>Item</u>	<u>Part Number</u>	<u>Qty.</u>	<u>Description</u>
1	810749	1	66-80 Transmission Assembly
2	110362	1	44 Transmission Adapter
3	110360	1	44 Suppressor Housing
4	110290	2	Motor Manifold
5	110330	6	Retainer Plate
6	110232	1	Serial Number Plate
7	810751	1	Terminal Manifold
8	100051	4	.375-16 X 1.0 Lg SHCS Locwel
9	110630	2	FITT2S-08M06P000-000H001
10	110358	2	Stop Bars
11	300099	2	FITT2S-10R08M000-000H001
12	140111	44	.75-10 X 4.0 Lg SHCS Locwel
13	100069	44	.75 Lock Washer Medium
14	100773	6	.625-11UNC X 3.50Lg SHCS
15	140907	2	HOSE150PT6F024F024L0835C
16	100121	16	.5 Lock Washer Medium
17	100011	4	.5-13 X 2.0 Lg SHCS
18	110236	6	.625 Flat Washer Extra Heavy
19	100007	6	.625 Lock Washer-Medium
20	400213	2	FITT2P-06P000000-000S007
21	100063	4	FITT2P-16P000000-000S007
22	110055	2	FITT2P-20P000000-000S007
23	100486	2	HOSE050R01J008J008L01450
24	400203	2	FITT2S-06M06P000-000H001
25	400227	4	FITT2L-06M06P000-0000001
26	100423	2	FITT2P-08P000000-000S007
27	140905	2	HOSE038R02J006J006L0835C
28	100596	4	#24 Split Flange Half
29	100119	8	.5-13 X 1.25 Lg Shcs Locwel
30	110119	6	2-225 O-Ring
31	100049	2	#12 Split Flange Half
32	140903	1	HOSE075PT4F012FO12L0835C
33	100782	144	.75-10 Flange Nut
34	100097	1	2-214 O-Ring 70 DURO
35	110356	1	Hose Chute
36	400043	14	.5-13 X 2.25 Lg SHCS
37	110354	1	Hose Chute Support
38	100213	10	1.0-8 X 2.5 Lg SHCS LOCWEL
39	100209	4	1.0 Lock Washer Medium
40	140145	2	1.0-8 X 3.5 Lg SHCS



MODEL 66-80
VIBRATORY
DRIVER/EXTRACTOR

PARTS LIST



MODEL 66-80
VIBRATORY
DRIVER/EXTRACTOR

PARTS LIST

VIBRATION SUPPRESSOR

800503

<u>Item</u>	<u>Part Number</u>	<u>Qty.</u>	<u>Description</u>
41	400051	2	1.0-8 Hex Nut
42	100796	24	Elastomer
43	400069	96	.75-10 X 2.0 Lg SHCS
44	100067	48	.75-10 X 2.5 Lg SHCS Locwel
45	100814	1	Sealant
46	110747	4	6 Logo Plate
47	400278	2	J&M Logo Plate
48	100037	4	2-222 O-Ring 70 DURO
51	110224	1	66-80 Hose Clamp
52	140095	1	Hose Clamp
53	100614	2	.50-13UNC X 1.50 Lg SHCS



MODEL 66-80
VIBRATORY
DRIVER/EXTRACTOR

PARTS LIST

VIBRATION CASE

810749

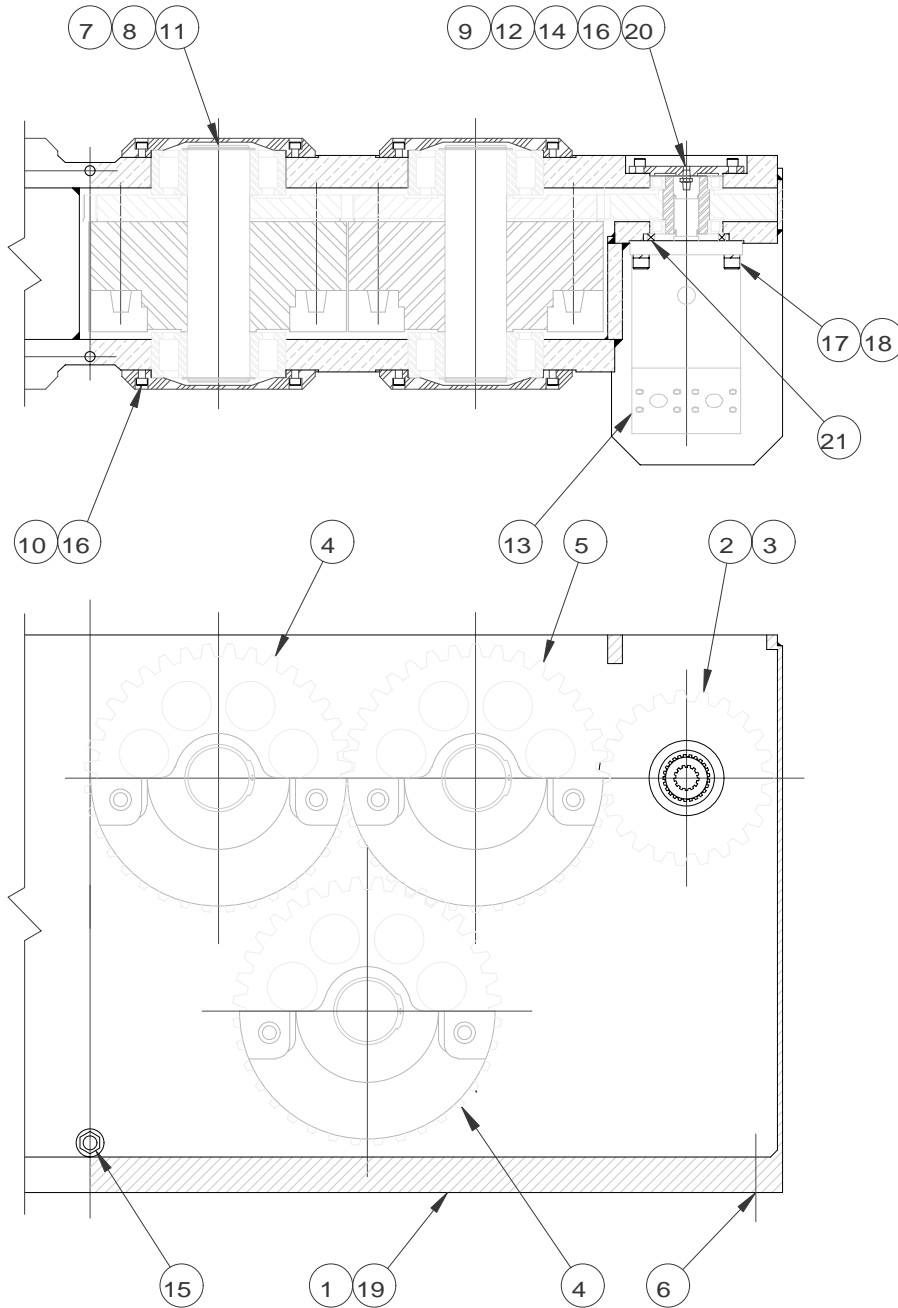



MODEL 66-80
VIBRATORY
DRIVER/EXTRACTOR

PARTS LIST

VIBRATION CASE

810749

<u>Item</u>	<u>Part Number</u>	<u>Qty.</u>	<u>Description</u>
1	810017	1	66 Transmission Case Frame
2	110370	2	Pinion Shaft (46)
3	110376	2	Pinion Gear
4	810673	2	44 Eccentric Gear Assembly
5	810675	2	44 Eccentric Gear Assembly
6	100187	2	FITT2P-12P000000-000SOM7
7	110316	8	Retaining Ring
8	110372	4	Eccentric Shaft
9	110366	2	Bearing Housing
10	110368	8	Bearing Cover
11	110314	8	Eccentric Bearing
12	110312	4	Motor Bearing
13	140679	2	Drive Motor (M)
14	100822	2	Breather
15	100185	1	Sight Gauge
16	100119	56	.5-13 X 1.25 Lg SHCS Locwel
17	100067	8	.75-10 X 2.5 Lg SHCS Locwel
18	400727	8	.75 Hi-Collar Lock Washer
19	110444	3	Transmission Oil / Gal.
20	100662	2	Filter
21	110222	2	Motor Bearing Bushing



MODEL 66-80
VIBRATORY
DRIVER/EXTRACTOR

PARTS LIST

TERMINAL MANIFOLD

810751

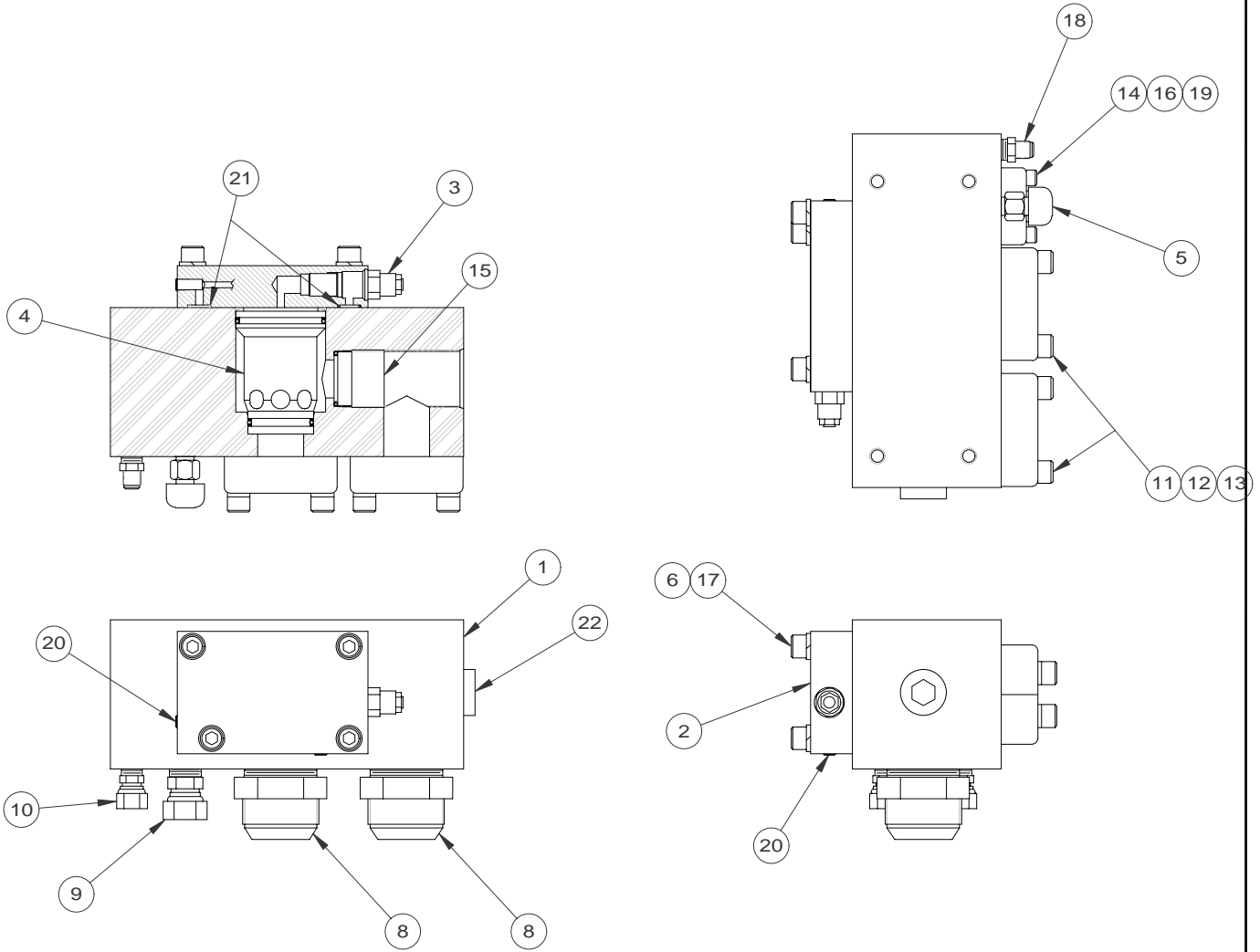



MODEL 66-80
VIBRATORY
DRIVER/EXTRACTOR

PARTS LIST

TERMINAL MANIFOLD

810751

<u>Item</u>	<u>Part Number</u>	<u>Qty.</u>	<u>Description</u>
1	110352	1	Terminal Block
2	110252	1	Manifold Cap
3	110242	1	Brake Valve Relief (RV5)
4	110622	1	Cartridge B (BV)
5	110214	1	Relief Valve (RV3)
6	100121	4	.5 Lock Washer Medium
8	110269	2	FITT2S-32M24P000-000H001
9	100043	1	FITT2S-12P12N000-000H001
10	100041	2	FITT2S-06PO6N000-000H001
11	100596	4	#24 Split Flange Half
12	100119	8	.5-13 X 1.25 Lg SHCS Locwel
13	110119	2	2-225 O-Ring
14	100049	2	#12 Split Flange Half
15	110296	1	Check Valve (CV6)
16	100097	1	2-214 O-Ring 70 DURO
17	400043	4	.5-13 x 2.25 Lg SHCS
18	400203	2	FITT2S-06M06P000-000H001
19	100051	4	.375-16 X 1.0 Lg SHCS Locwel
20	100646	2	FITT2P-02P000000-000S007
21	140255	2	2-113 O-Ring
22	110298	1	FITT2P-24R000000-000S001



MODEL 66-80
VIBRATORY
DRIVER/EXTRACTOR

PARTS LIST

HOSE ASSEMBLIES - INTERCONNECTING

800405

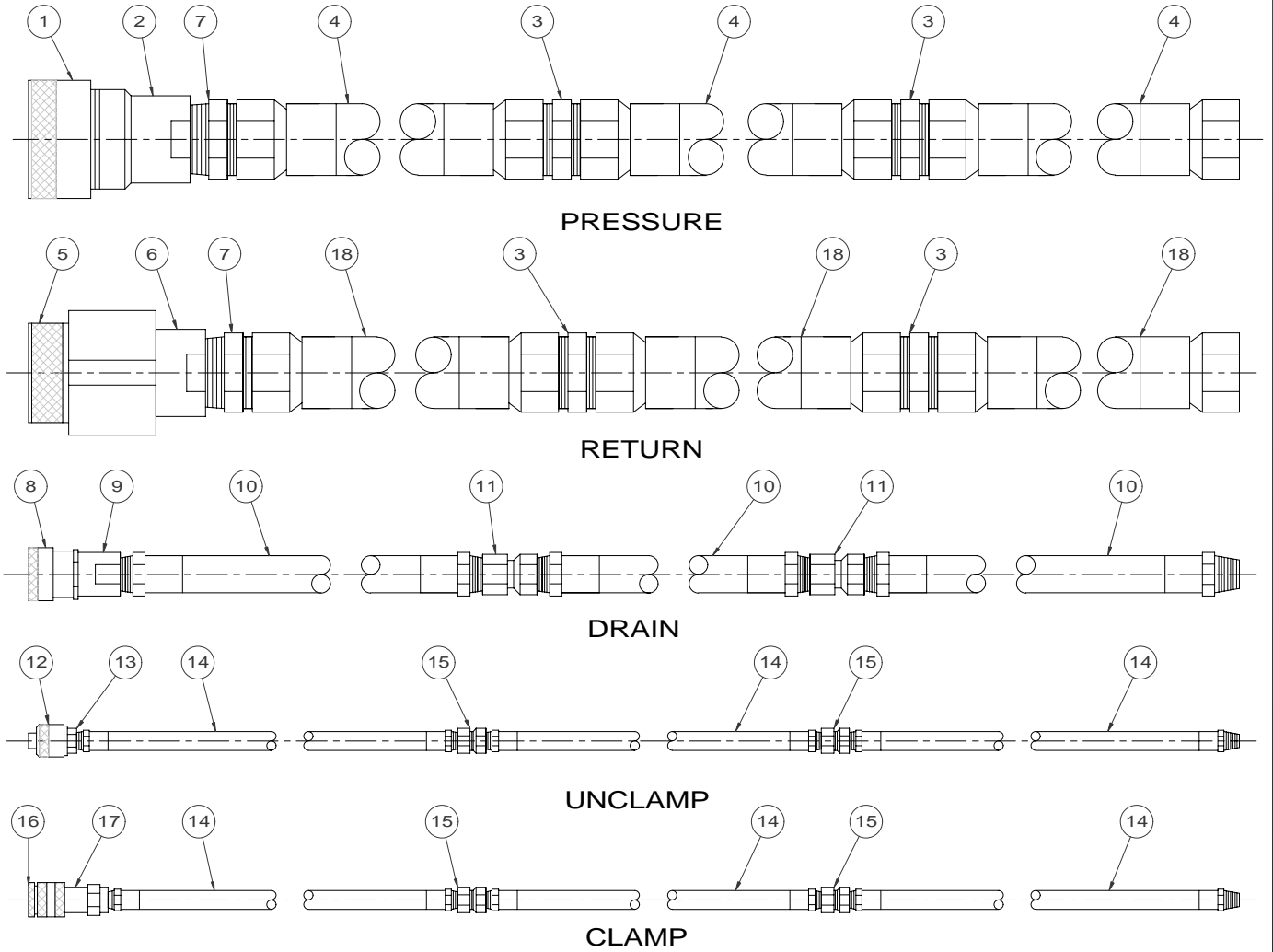



MODEL 66-80
VIBRATORY
DRIVER/EXTRACTOR

PARTS LIST

HOSE ASSEMBLIES - INTERCONNECTING

800405

<u>Item</u>	<u>Part Number</u>	<u>Qty.</u>	<u>Description</u>
1	140041	1	Dust Cap (2")
2	140037	1	Male Disconnect (2")
3	110271	4	FITT2S-32M32M000-000H001
4	140683	3	HOSE200R13J032J032L60000
5	140039	1	Dust Plug (2")
6	140035	1	Female Disconnect (2")
7	140523	2	FITT2S-32M32P000-000H001
8	120029	1	Dust Cap (1")
9	120023	1	Male Disconnect (1")
10	140685	3	HOSE100PT4P016P016L62000
11	140357	2	FITT2S-16Q16N000-000H001
12	100257	1	Dust Cap (3/8)
13	100245	1	Male Disconnect (3/8)
14	100247	6	HOSE038R02P006P006L62000
15	100249	4	FITT2S-06Q06N000-000H001
16	100737	1	Dust Plug (3/8)
17	100777	1	Female Disconnect (3/8)
18	110970	3	HOSE200R09J032J032L60000
	130243	20	Rubber Tie Down



MODEL 66-80
VIBRATORY
DRIVER/EXTRACTOR

PARTS LIST

POWER UNIT ENCLOSURE

810589

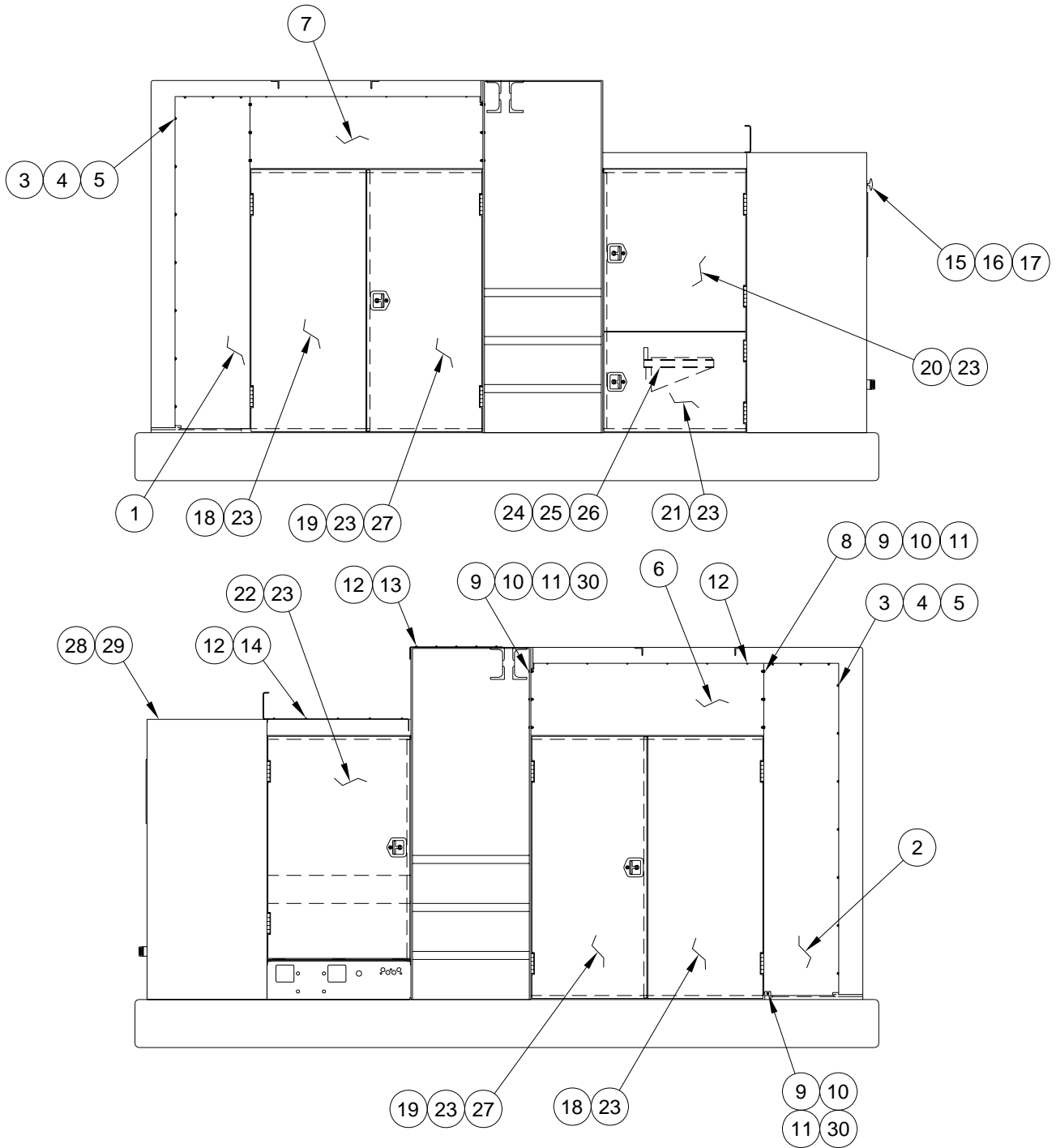



MODEL 66-80
VIBRATORY
DRIVER/EXTRACTOR

PARTS LIST

POWER UNIT ENCLOSURE

810589

<u>Item</u>	<u>Part Number</u>	<u>Qty.</u>	<u>Description</u>
1	140621	1	Cover
2	140623	1	Cover
3	100557	20	.25-20 X .75 Lg SHCS
4	100559	20	.25 Lock Washer
5	100597	32	.25 Flat Washer
6	140613	1	Right Cover Panel
7	140661	1	Left Cover Panel
8	150179	6	.312-18 X .75 Lg. HHCS
9	100287	14	.312 Lock Washer
10	100293	14	.312 Flat Washer
11	100289	14	.312-18 Hex Nut
12	130209	32	.25-14 X 1 Hex Tex
13	140653	1	Bale Cover
14	140651	1	Unit Cover
15	110221	1	Door Hold Down
16	110861	2	10-32 X .5 Lg. PHMS
17	400161	2	#10 Lock Washer
18	140619	2	Cover Door
19	140617	2	Cover Door
20	140189	1	Cover Door
21	140187	1	Cover Door
22	140185	1	Cover Door
23	100834	14	5" Door Hinge
24	100600	1	Hex Key Rack
25	810045	1	Hex Key Group
26	100651	1	24 V Test Light
30	100309	8	.312-18 x 1.0 Lg BHCS



MODEL 66-80
VIBRATORY
DRIVER/EXTRACTOR

PARTS LIST

CONTROL BOX ASSEMBLY

810593

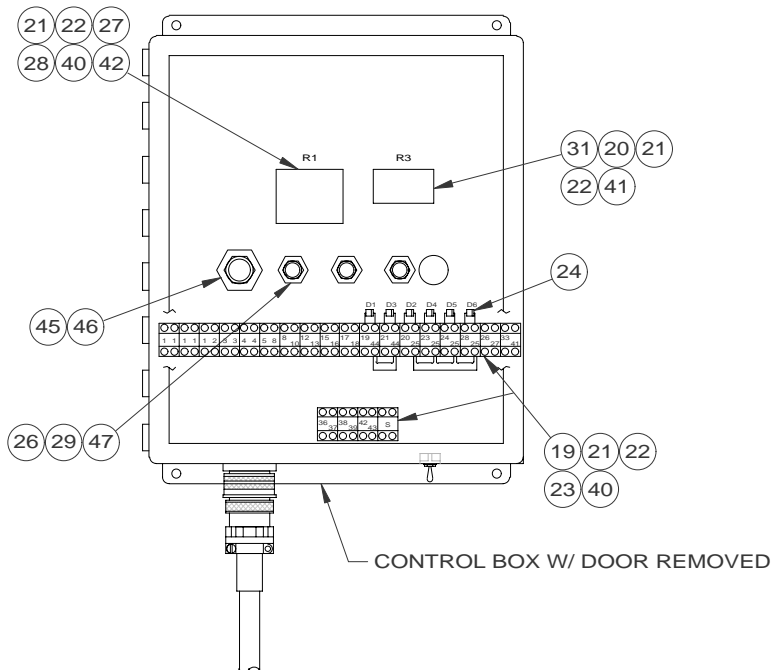
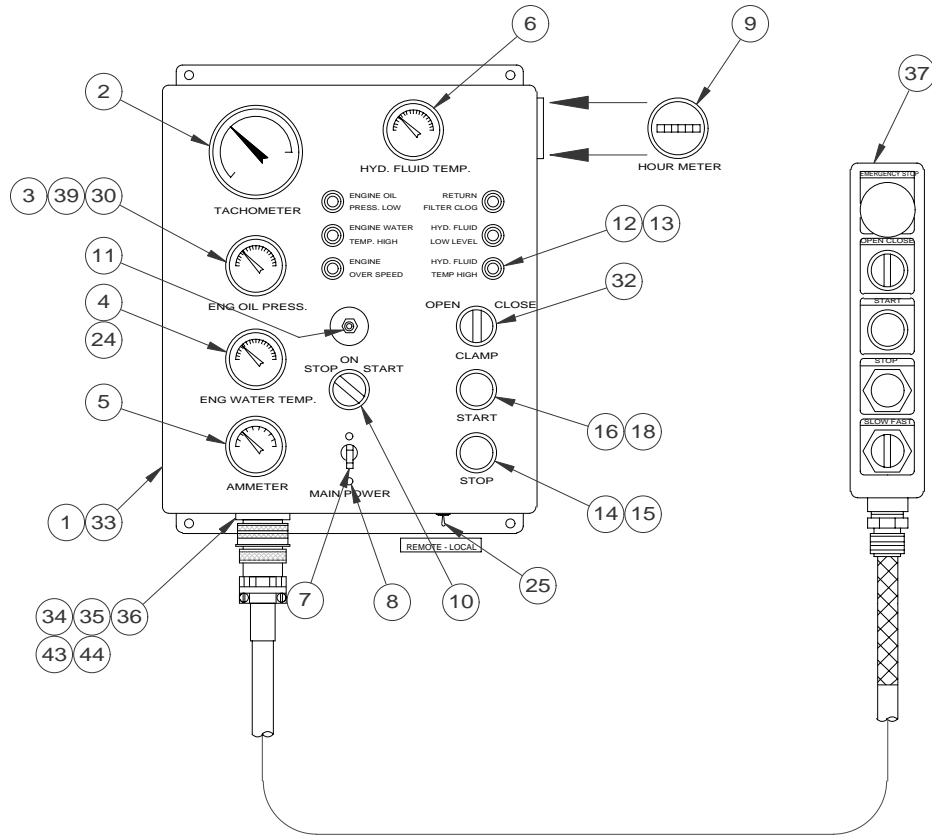



MODEL 66-80
VIBRATORY
DRIVER/EXTRACTOR

PARTS LIST

CONTROL BOX ASSEMBLY

810593

<u>Item</u>	<u>Part Number</u>	<u>Qty.</u>	<u>Description</u>
1	110652	1	Control Box
2	110650	1	Tachometer
3	100329	1	Oil Pressure Gauge
4	110697	1	Water Temperature Gage
5	110371	1	Ammeter
6	110640	1	Hydraulic Temperature Gauge (TS2)
7	400141	1	Circuit Breaker-10 A (CB2)
8	100331	2	#6-32 X .25 Lg BHCS
9	100343	1	Hourmeter (M1)
10	110615	1	Engine Start Switch
11	110456	1	Murphy Switch
12	100355	6	Dialight, Test (L1 - L6)
13	130305	7	Warning Light Bulb
14	100363	1	Pushbutton (STOP)
15	100365	1	Rubber Dust Cap-Red
16	110598	1	Start Button (w/ Clamp Light)
18	110596	1	Lens
19	110569	15	Terminal Mtg. Channel/In
20	110861	2	10-32 X .5 Lg. PHMS
21	400163	9	#10-32 Hex Nut
22	400161	9	#10 Lock Washer
23	110567	22	Terminal Block
24	100413	7	Diode (D1 - D6 & D8)
25	140361	1	Toggle Switch
26	110841	3	.5 Plastic Bushing
27	140281	4	Relay Mtg. Track/In.
28	110584	1	Relay (R1)
29	110843	3	.5 Lock Nut
30	100333	1	FITT2L-04E02Q000-000H002
31	110604	1	Relay (R3)
32	130155	1	Switch (OPEN / CLOSE)
33	140733	1	950 Label Group
34	110763	1	Female Amphenol Insert
35	100397	1	Amphenol Receptacle
36	110754	4	#6-32 X .375 Lg RHMS
37	800395	1	570-950 Pendant Asm.
39	110415	11	.250 Oil Pressure Tube/Ft
40	110649	7	#10-32 X .375 Lg PHMS



MODEL 66-80
VIBRATORY
DRIVER/EXTRACTOR

PARTS LIST



MODEL 66-80
VIBRATORY
DRIVER/EXTRACTOR

PARTS LIST

CONTROL BOX ASSEMBLY

810593

<u>Item</u>	<u>Part Number</u>	<u>Qty.</u>	<u>Description</u>
41	300671	2	#10 Flat Washer
42	140345	1	Channel Bracket
43	110696	4	#6 Lock Washer
44	110694	4	#6-32 Hex Nut
45	110693	1	1" 90 Deg Compress Fitting
46	110839	1	1.0 Plastic Bushing
47	100853	3	90 Deg S/O Comp Fitting



MODEL 66-80
VIBRATORY
DRIVER/EXTRACTOR

PARTS LIST

570-950 PENDANT ASSEMBLY

800395

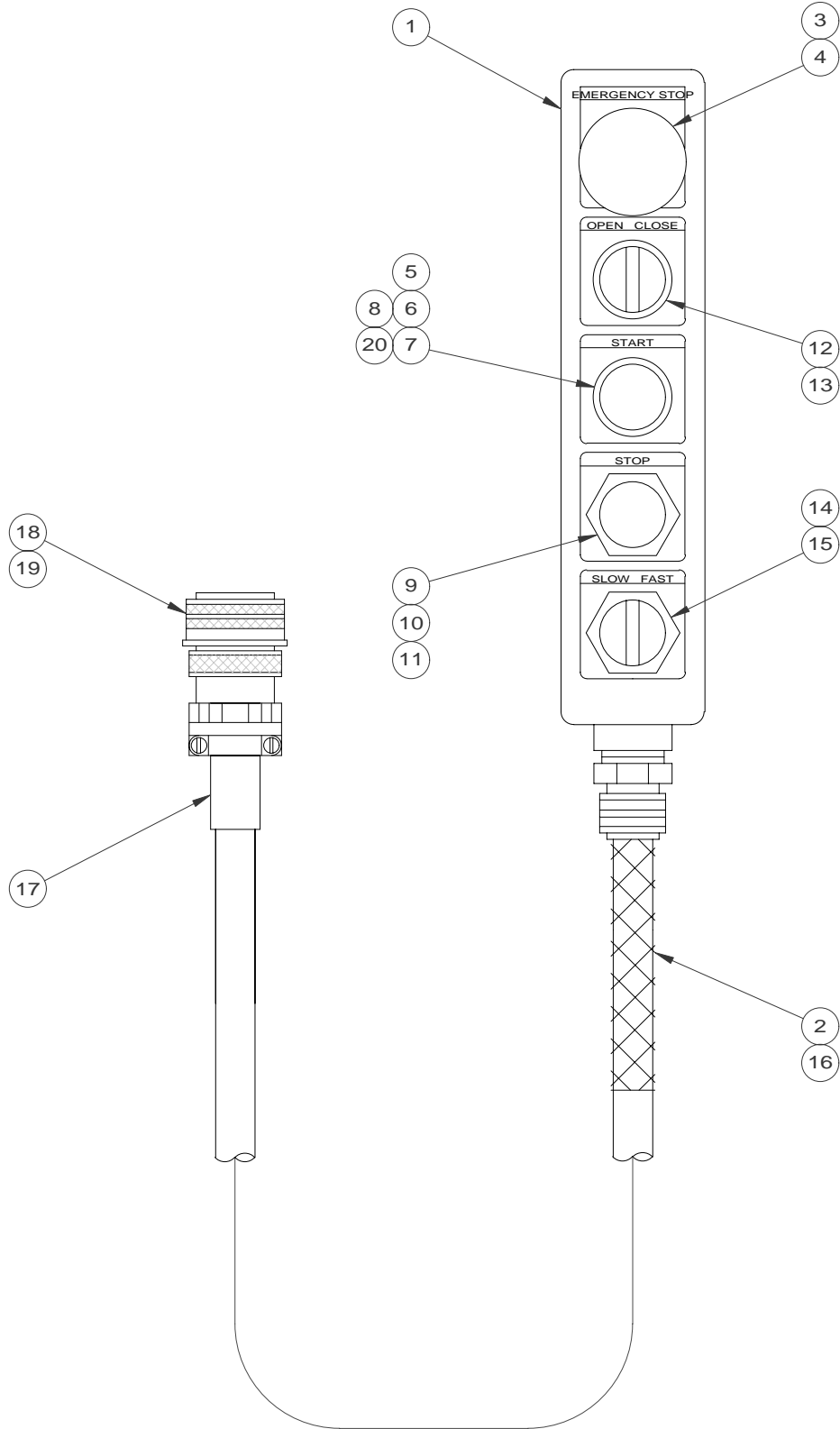



MODEL 66-80
VIBRATORY
DRIVER/EXTRACTOR

PARTS LIST

570-950 PENDANT ASSEMBLY

800395

<u>Item</u>	<u>Part Number</u>	<u>Qty.</u>	<u>Description</u>
1	130505	1	Pendant Box
2	110603	1	1.0 Strain Relief
3	130507	1	Emergency Stop Button
4	130509	1	Emergency Stop Label
5	110598	1	Start Button (w/ Clamp Light)
6	110594	1	Guard
7	110596	1	Lens
8	100407	1	Start Nameplate
9	100363	1	Pushbutton (STOP)
10	100405	1	Stop Nameplate
11	100365	1	Rubber Dust Cap-Red
12	130155	1	Switch (OPEN / CLOSE)
13	100401	1	Open / Close Nameplate
14	100566	1	Switch (SLOW - FAST)
15	100562	1	Slow-Fast Nameplate
16	100560	50	Pendant Cable / Ft
17	100375	1	Strain Relief-Amphenol
18	110761	1	Male Amphenol Insert-Plug
19	100395	1	Amphenol Plug
20	130305	1	Warning Light Bulb



MODEL 66-80
VIBRATORY
DRIVER/EXTRACTOR

PARTS LIST

POWER UNIT-INTERNAL (right side and left side)

800385

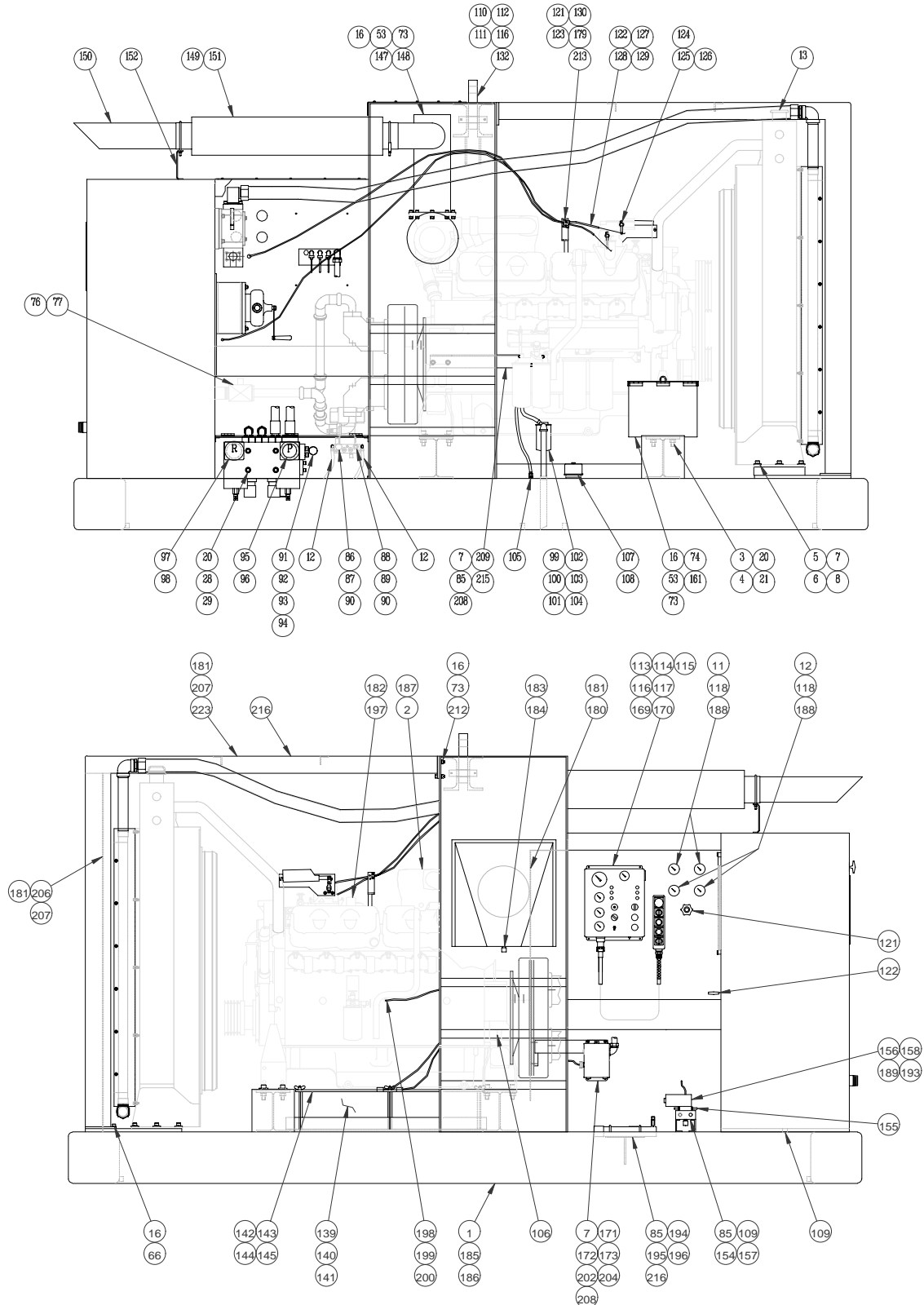



MODEL 66-80
VIBRATORY
DRIVER/EXTRACTOR

PARTS LIST

POWER UNIT-INTERNAL
(front view, reservoir detail, gaer box detail and manifold detail)

800385

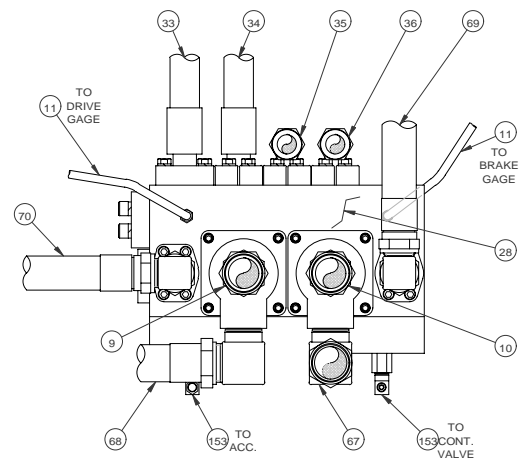
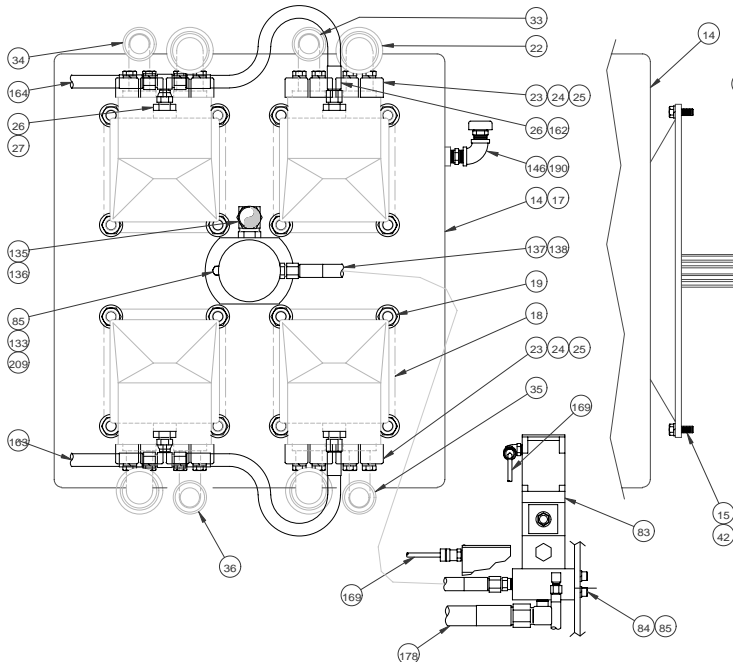
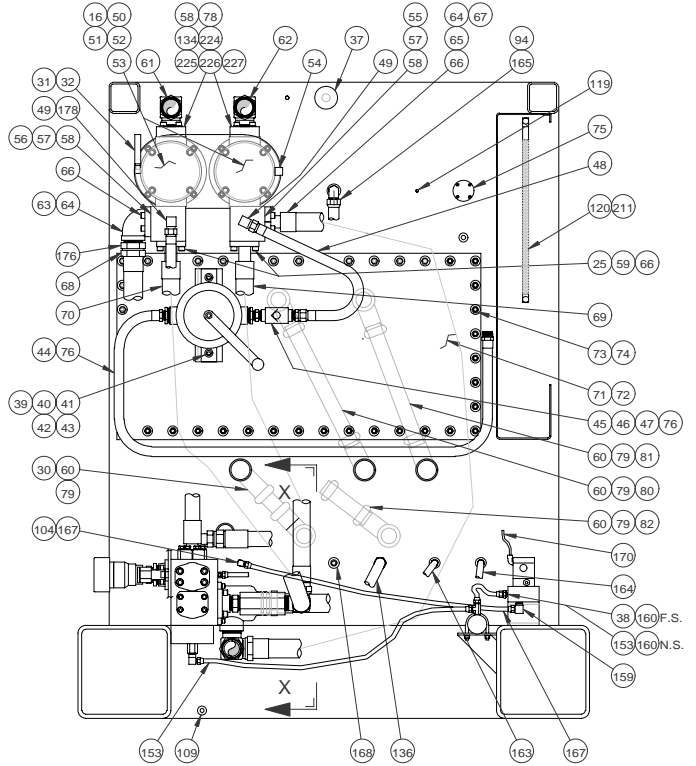
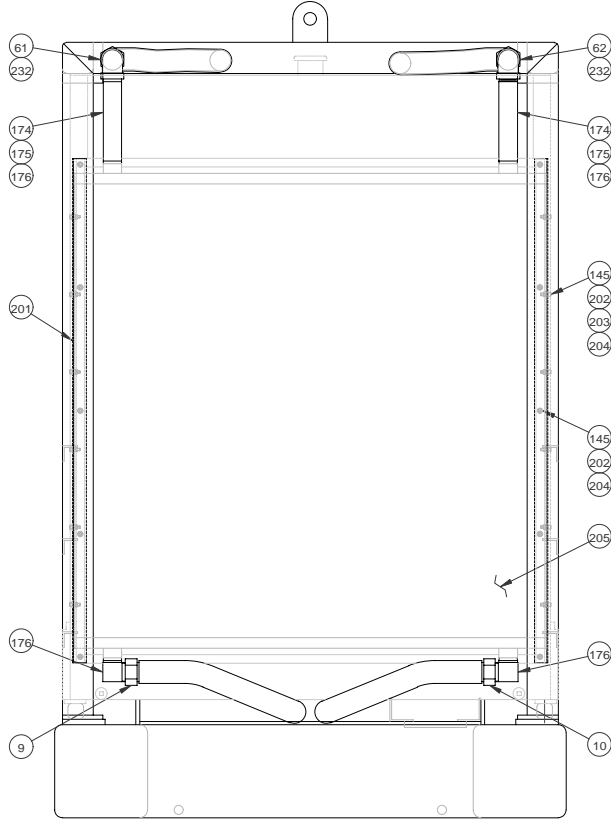

VIEW X-X



**MODEL 66-80
VIBRATORY
DRIVER/EXTRACTOR**

PARTS LIST

POWER UNIT-INTERNAL (electric throttle detail)

800385

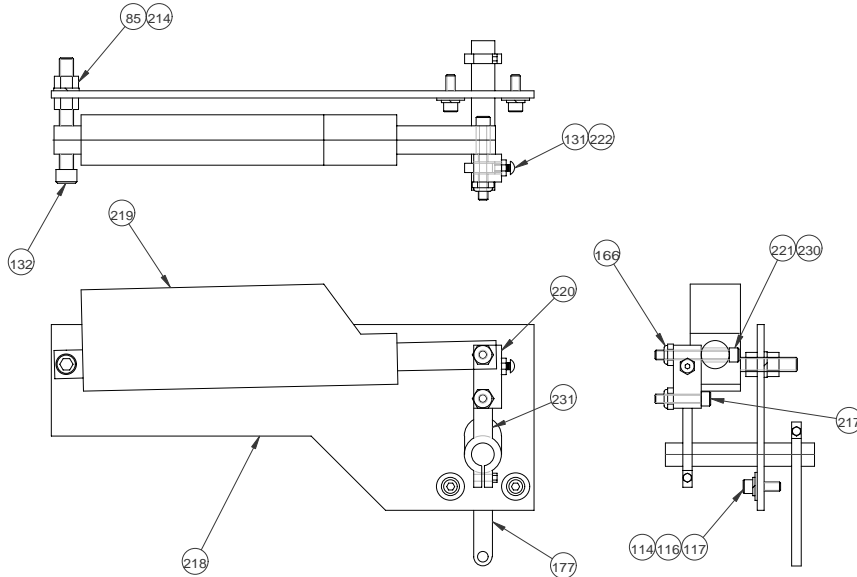

Item	Part Number	Qty.	Description
1	810587	1	950 Subbase Asm
2	140687	1	3412DITA Engine (800 Hp)
3	100067	12	.75-10 X 2.5 Lg Shcs Locwel
4	100587	12	.75-10 Hex Nut
5	130141	6	.625 Flat Washer
6	130135	6	.625-11 X 3.5 Lg SHCS
7	100007	10	.625 Lockwasher
8	140765	2	Spacer
9	140753	1	HOSE200R01J032J032L17200
10	140755	1	HOSE200R01J032J032L18300
11	130393	2	HOSE019AQ1J004J004L11000
12	140735	2	HOSE025R02J004J004L11700
13	100726	22	Antifreeze/Gal
14	140837	1	Multi-Pump Adapter (5)
15	100462	12	.437-14 Unc X 1.25 Lg HHCS
16	100121	38	.50 Lockwasher Medium
17	100735	1	Transmission Oil/Gal
18	140829	4	Drive Pump (800)
19	100782	16	.75-10 Flange Nut
20	100069	16	.75 Lockwasher Medium
21	100589	12	.75 Flatwasher
22	140769	4	90 Deg. Bent Stem Adapter
23	110103	32	16MM X 40MM Lg SHCS
24	110243	16	#24 Split Flange Half 6000
25	110119	10	2-225 O-Ring



MODEL 66-80
VIBRATORY
DRIVER/EXTRACTOR

PARTS LIST

POWER UNIT-INTERNAL

800385

<u>Item</u>	<u>Part Number</u>	<u>Qty.</u>	<u>Description</u>
26	110984	4	FITT2S-12S08M000-000H0F1
27	140757	2	FITT2T-08M08M08J-000H001
28	810591	1	950 Control Manifold Asm
29	400275	4	.75-10 X 1.50 Lg SHCS
30	140771	1	2.5 SCH 40 Pipe X 4"Lg
31	100775	1	Visual Indicator
32	100838	1	FITT2L-02P04Q000-00L0001
33	140715	1	HOSE125PT4H020H924L05600
34	140717	1	HOSE125PT4H020H924L06400
35	140719	1	HOSE125PT4J020H924L02200
36	140721	1	HOSE125PT4J020H924L03200
37	100455	1	Breather
38	100108	1	HOSE038R02J006J006L0200S
39	100447	1	Hand Pump
40	130091	1	Pump Mounting Bracket
41	100439	2	.437-X 1.75 LG SHCS
42	100443	14	.437 Lockwasher
43	400153	2	.437 Flatwasher
44	400215	1	HOSE100R01P016P016L08400
45	100449	1	FITT2S-16P16P000-000H001
46	100451	1	Check Valve
47	300119	1	FITT2S-16P12M000-000H001
48	300115	1	HOSE075R01J012J012L02600
49	100489	2	FITT2L-12M2P000-0000001
50	140179	2	Return Filter
51	140403	2	Filter Element
52	140543	2	Return Filter Gasket
53	100513	18	.5-13 X 1.5 Lg SHCS
54	140413	1	Return Filt. Press. Sw.
55	140649	1	Filter Adapter
56	140663	1	Filter Adapter
57	100025	8	.5-13 X 4.5 Lg SHCS
58	400379	4	2-232 O-Ring
59	100596	4	#24 Split Flange Half
60	400808	4	FITT2S-40P000000-0900001
61	140845	1	HOSE200R01J032J032L13900
62	140849	1	HOSE200R01J032J032L15000
63	140775	1	2"NPT 90 Deg Flanged Adapter
64	140233	2	2-228 O-Ring
65	140261	2	#32 Pa Split Flange Half
66	100119	22	.5-13 X 1.25 Lg SHCS Locwel
67	140729	1	HOSE200R01J032F032L09000



MODEL 66-80
VIBRATORY
DRIVER/EXTRACTOR

PARTS LIST

POWER UNIT-INTERNAL

800385

<u>Item</u>	<u>Part Number</u>	<u>Qty.</u>	<u>Description</u>
68	140727	1	HOSE200RO1J032J032L09900
69	140723	1	HOSE150RO1J024F024L04800
70	140725	1	HOSE150R01J024F024L08700
71	140115	1	Cover Plate
72	140219	1	Cover Plate Gasket
73	100485	58	.5-13 Hex Nut
74	100483	46	.5 Flatwasher
75	100314	1	Float Switch
76	110089	2	FITT2S-20P16Q000-000H001
77	400117	4	Stop Cock
78	100746	2	FITT2L-48P48Q000-0000406
79	400195	8	2.5-90 Deg Flexible Coupling
80	140781	1	2.5"Sch 40 Pipe X 17"Lg.
81	140783	1	2.5 Sch 40 Pipe X 16"Lg.
82	140785	1	2.5 Sch 40 Pipe X 7"Lg.
83	810449	1	570c Clamp Manifold Assembly
84	100648	3	.375-16 X .875 Lg SHCS
85	400149	17	.375 Lockwasher
86	100245	1	.375 Male Disconnect
87	100257	1	.375 Dust Cap
88	100777	1	.375 Female Disconnect
89	100737	1	.375 Dust Plug
90	130203	2	FITT2S-06P06P000-0300401
91	120095	1	FITT2S-16P16B000-000H001
92	120025	1	1" Female Disconnect
93	120027	1	1" Dust Plug
94	140990	1	HOSE100R01J016J016L08000
95	140035	1	2" Female Disconnect
96	140039	1	2" Dust Plug
97	140037	1	2" Male Disconnect
98	140041	1	2" Dust Cap
99	120611	1	Water Seperator Asm.
100	120613	1	Water Seperator Element
101	110377	1	FITT2L-16P16Q000-0000306
102	120425	1	FITT2S-16P16P000-1200301
103	100715	1	FITT2S-16P06Q000-000H001
104	400227	1	FITT2L-06M06P000-0000001
105	140913	1	FITT2S-06P04M000-000H001
106	100408	1	Magnetic Pick-Up(300-570)
107	100417	1	FITT2C-48Q000000-0000306
108	100419	1	Petcock
109	100423	4	FITT2P-08P000000-000S007



MODEL 66-80
VIBRATORY
DRIVER/EXTRACTOR

PARTS LIST

POWER UNIT - INTERNAL

800385

<u>Item</u>	<u>Part Number</u>	<u>Qty.</u>	<u>Description</u>
110	140157	1	Link
111	140291	1	Pin
112	100722	2	Roll Pin .25 X 3.5
113	810593	1	950 Control Box Asm.
114	100557	6	.25-20 X .75 Lg SHCS
115	100598	4	.25-20 Hex Nut
116	100597	10	.25 Flatwasher
117	100559	6	.25 Lockwasher
118	110600	4	0-6000 Psi Gage
119	110590	1	Hydraulic Temperature
120	110355	1	Level Gauge
121	130255	1	Engine Throttle
122	140851	1	Emergency Stop Cable(950)
123	110452	1	Cable Bracket
124	110968	1	Key
125	110966	1	Shut-Down Arm
126	110964	1	Pivot
127	110962	1	Clamp
128	110960	1	Shim
129	100429	1	Throttle Cable Seal
130	400161	2	#10 Lockwasher
131	110827	1	10-32 X .75 BHCS S.S.
132	110163	3	.25-20 X 3.5 LG SHCS
133	140839	1	Clamp Pump (950)
134	100027	8	.5 Hi-Collar Lockwasher
135	100938	1	FITT2L-16M12R000-000H001
136	140875	1	HOSE100R01P016J016L04400
137	100139	1	FITT2S-08M08R000-000H001
138	140745	1	HOSE050PT4J008J008L04900
139	100529	2	Battery
140	140359	1	Battery Cable-6
141	110755	2	Battery Cable-15
142	810169	1	Dual Battery Hold Down
143	400231	3	Hold Down Stud
144	100831	3	.312 Wing Nut
145	100293	25	.312 Flatwasher
146	100705	1	FITT2S-08P08P000-000H001
147	140629	1	Exhaust Adapter
148	140787	1	Exhaust Adapter Gasket
149	110504	2	Muffler
150	140789	2	Exhaust Outlet
151	100297	4	Exhaust Pipe Clamp



MODEL 66-80
VIBRATORY
DRIVER/EXTRACTOR

PARTS LIST

POWER UNIT - INTERNAL

800385

<u>Item</u>	<u>Part Number</u>	<u>Qty.</u>	<u>Description</u>
152	110512	2	Muffler Support
153	140737	2	HOSE038PT4JOO6J006L04200
154	140675	1	Subplate
155	140677	1	Sandwich Relief Valve
156	140665	1	Solenoid Valve
157	100017	4	.375-16 X 2.00 Lg SHCS Locwel
158	140773	4	.25-20UNC X 2.38 Lg SHCS
159	110704	1	FITT2L-08P06M000-0000001
160	110171	2	FITT2S-08P06M000-000H001
161	100558	1	Tool Box
162	100486	2	HOSE050R01J008J008L01450
163	140741	1	HOSE050R01J008J008L03800
164	140743	1	HOSE050RO1J008J008L07000
165	120055	1	FITT2L-16M16P000-0000001
166	100422	3	.25-20 UNC Esna Nut
167	110633	1	HOSE038R02J006J006L0370S
168	100183	1	FITT2P-12P000000-000S007
169	110231	2	S/O Cord 12' Lg
170	110229	1	S/O Cord 6' Lg
171	810145	1	570 Engine Junction Box
172	110785	30	1"Sealtight/In
173	140791	1	Junction Box Bracket
174	140793	2	FITT2S-32P32P000-1400301
175	140795	2	FITT2L-32Q32Q000-0000001
176	140523	5	FITT2S-32M32P000-000H001
177	110446	1	Throttle Arm
178	140747	1	HOSE075R01J012J012L08800
179	110861	2	10-32 X .50 Lg. PHMS
180	140799	1	Hose Shield
181	130209	47	.25-14 X 1 Hex Tex
182	110447	1	Tack Drive Adapter
183	140507	2	FITT2S-02Q000000-0000306
184	140801	2	FITT2S-02P02P000-000H001
185	100299	7	Primer/Gal
186	100298	7	APE / J&M Yellow Paint/Gal
187	400247	76	Engine Oil/Quart
188	100321	4	FITT2L-04M04Q000-0000001
189	100853	1	90 Deg S/O Comp Fitting
190	140921	1	FITT2L-08Q08Q00-000H001
191	140803	8	.5-13UNC X 1.00 Lg HHCS
192	140805	1	Flex Plate
193	140387	1	Orifice-.059



MODEL 66-80
VIBRATORY
DRIVER/EXTRACTOR

PARTS LIST

POWER UNIT - INTERNAL

800385

<u>Item</u>	<u>Part Number</u>	<u>Qty.</u>	<u>Description</u>
194	810295	1	#10 Accumulator
195	400413	1	FITT2T-06M06P06M-0000001
196	100461	2	U-Bolt
197	110759	1	Overspeed Switch
198	110369	1	FITT2S-06P04Q000-000H001
199	110871	1	FITT2V-04P04E000-000H002
200	110415	10	.250 Oil Pressure Tube/Ft
201	140615	2	Cooler Bracket
202	100105	24	.312-18 X 1.00 Lg SHCS Locwel
203	100289	12	.312-18 Hex Nut
204	100287	24	.312 Lockwasher
205	140763	1	Heat Exchanger
206	140625	1	Intake Grill
207	130227	37	.25 Fender Washer
208	100575	4	.625-11 X 1.25 Lg SHCS
209	140453	4	.375-16 X 1.00 Lg HHCS
210	400151	2	.375 Flatwasher
211	140415	475	Hydraulic Fluid/Gal
212	100163	6	.5-13 X 1.75 Lg SHCS Locwel
213	100577	1	Stop Cable Clamp
214	100535	6	.375 -16 Hex Nut
215	140807	1	Fuel Filter Housing Bracket
216	810589	1	950 Cover Group
217	100595	1	.25-20 X 1.25 Lg SHCS
218	110454	1	Electric Throttle Bracket
219	110460	1	Electric Actuator(24V)
220	110448	1	Adjustable Link
221	100631	1	.25-20 X 2.00 Lg SHCS
222	400163	1	#10-32 Hex Nut
223	140627	1	Top Grill
224	810009	2	FITT2L-32M32P000-00000F1
225	400233	2	FITT2S-40P32Q000-000H306
226	100946	2	Mfp Flange
227	110735	8	.5-13 X 2.50 Lg SHCS
229	100631	1	.25-20 X 2.00 Lg SHCS
230	100422	3	.25-20 UNC Esna Nut
231	810617	1	Modified Throttle Arm
232	140847	20	Fire Sleeve / Ft
233	100746	2	FITT2L-48P48Q000-0000406



MODEL 66-80
VIBRATORY
DRIVER/EXTRACTOR

PARTS LIST



**MODEL 66-80
VIBRATORY
DRIVER/EXTRACTOR**

PARTS LIST

JUNCTION BOX

810145

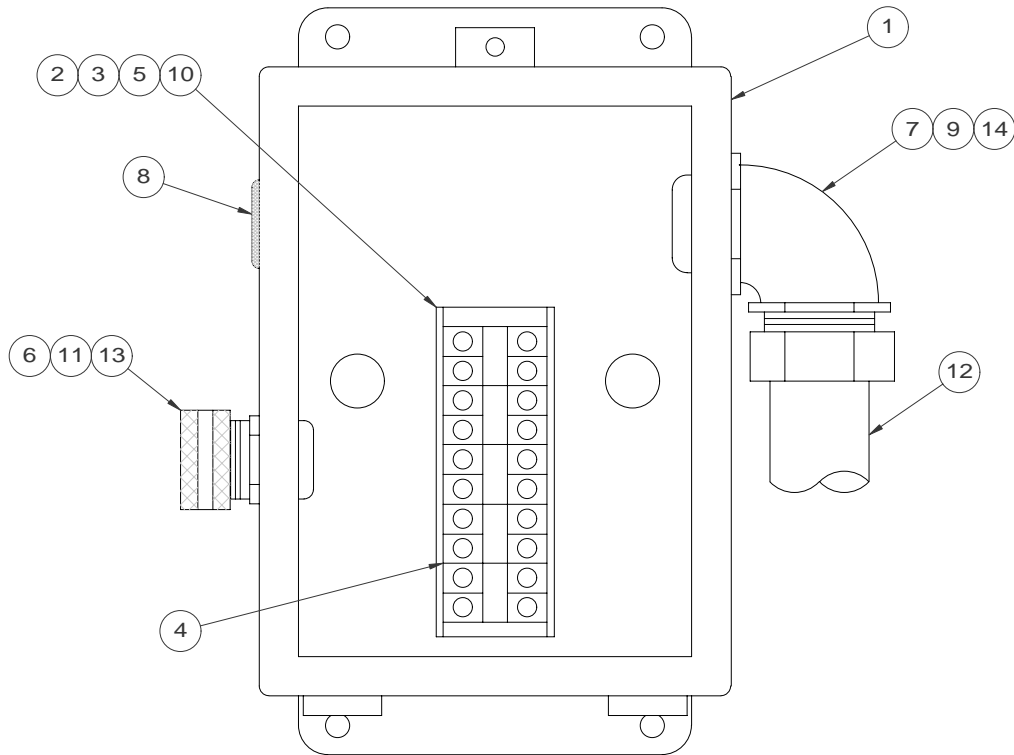

Item	Part Number	Qty.	Description
1	110699	1	Junction Box
2	400161	2	#10 Lock Washer
3	400163	2	10-32 Hex Nut
4	110567	5	Terminal Block
5	110569	1	Terminal Mounting Channel
6	100855	1	Straight Wire Connector
7	110693	1	90° Connector
8	110701	1	Grommet
9	110845	1	Lock Nut (1.0)
10	110649	2	10-32 x .375 Lg PHMS
11	110841	1	Plastic Bushing (.5)
12	110785	61	1" Sealtight / Inch
13	110843	1	Lock Nut (.5)
14	110839	1	Plastic Bushing (1.0)



MODEL 66-80
VIBRATORY
DRIVER/EXTRACTOR

PARTS LIST

CONTROL MANIFOLD ASSEMBLY

810591

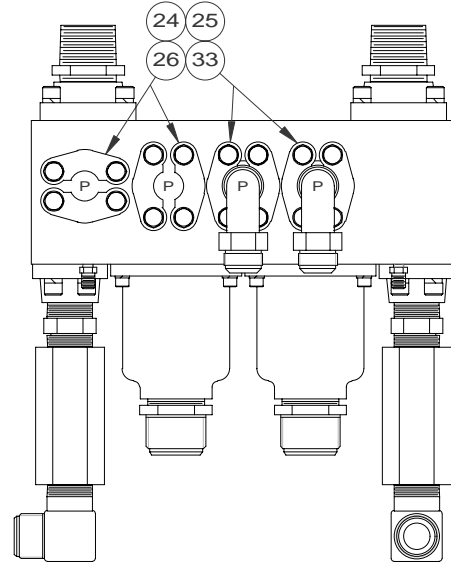
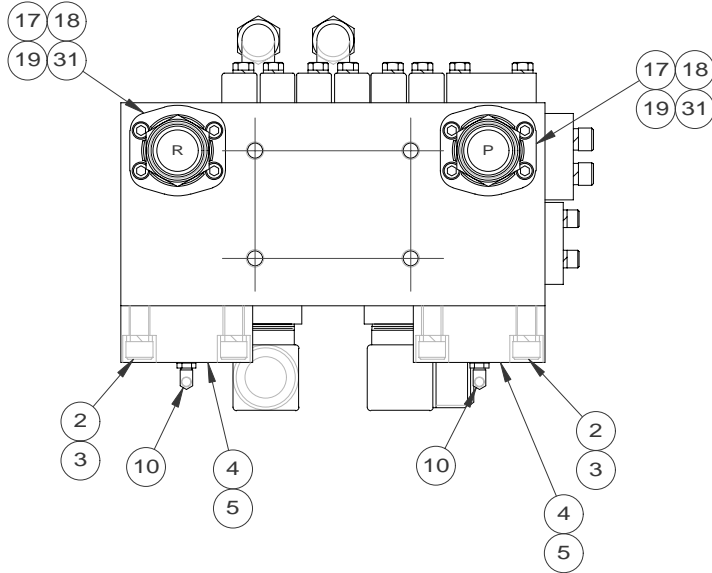

VIEW A-A

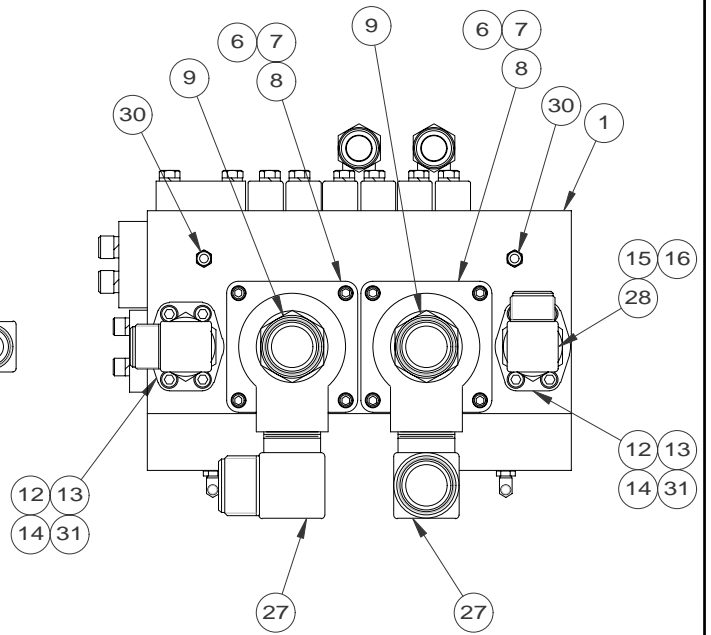
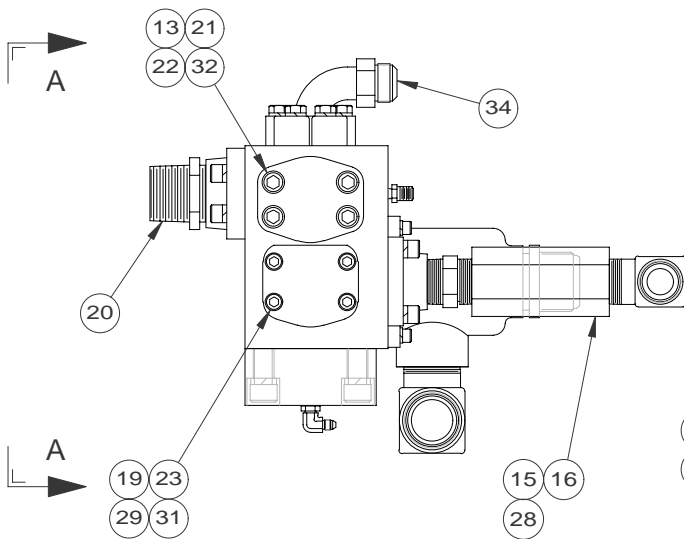



MODEL 66-80
VIBRATORY
DRIVER/EXTRACTOR

PARTS LIST

CONTROL MANIFOLD ASSEMBLY

810591

<u>Item</u>	<u>Part Number</u>	<u>Qty.</u>	<u>Description</u>
1	140611	1	950 Drive Manifold Block
2	140669	2	Cartridge Valve (C2)
3	140671	2	Cartridge Cover
4	400545	8	.75-10 UNC X 3.00 Lg SHCS
5	400727	8	.75 Hi-Collar Lock Washer
6	110628	2	Cooler Valve (V3)
7	100143	8	.375-16 X 1.25 Lg SHCS Locwel
8	400149	8	.375 Lock Washer
9	140523	2	FITT2S-32M32P000-000H001
10	140911	2	FITT2L-06R04M000-000H001
12	110057	2	1.5 Solid Flange
13	110119	3	2-225 O-Ring
14	100011	8	.50-13 X 2.00 Lg SHCS
15	110037	2	FITT2S-24P24P000-000H001
16	130339	2	1.50 Check Valve (CV3 & CV4)
17	140895	2	2.00 Solid Flange
18	110735	8	.50-13 X 2.50 Lg SHCS
19	140233	3	2-228 O-Ring
20	400235	2	FITT2S-32P32P000-000H001
21	140673	1	#24PH Blank Flange
22	140227	4	.625-11 x 2.00 Lg SHCS
23	400937	1	2" Blank Flange
24	110986	8	#20 PH Split Flange Half
25	100037	4	2-222 O-Ring 70 DURO
26	400739	16	.5-13 UNC X 2.00 Lg HHCS
27	810009	2	FITT2L-32M32P000-00000F1
28	100588	2	FITT2L-24M24P000-0000001
29	100513	4	.5-13 X 1.50 Lg SHCS
30	140267	2	FITT2S-04M02P000-000H001
31	100027	20	.50 Hi-Collar Lock Washer
32	130261	4	.625 Hi-Collar Lock Washer
33	100121	16	.50 Lock Washer Medium
34	140853	2	FITT2L-20H20M000-0000001



MODEL 66-80
VIBRATORY
DRIVER/EXTRACTOR

PARTS LIST

CLAMP MANIFOLD ASSEMBLY

810449

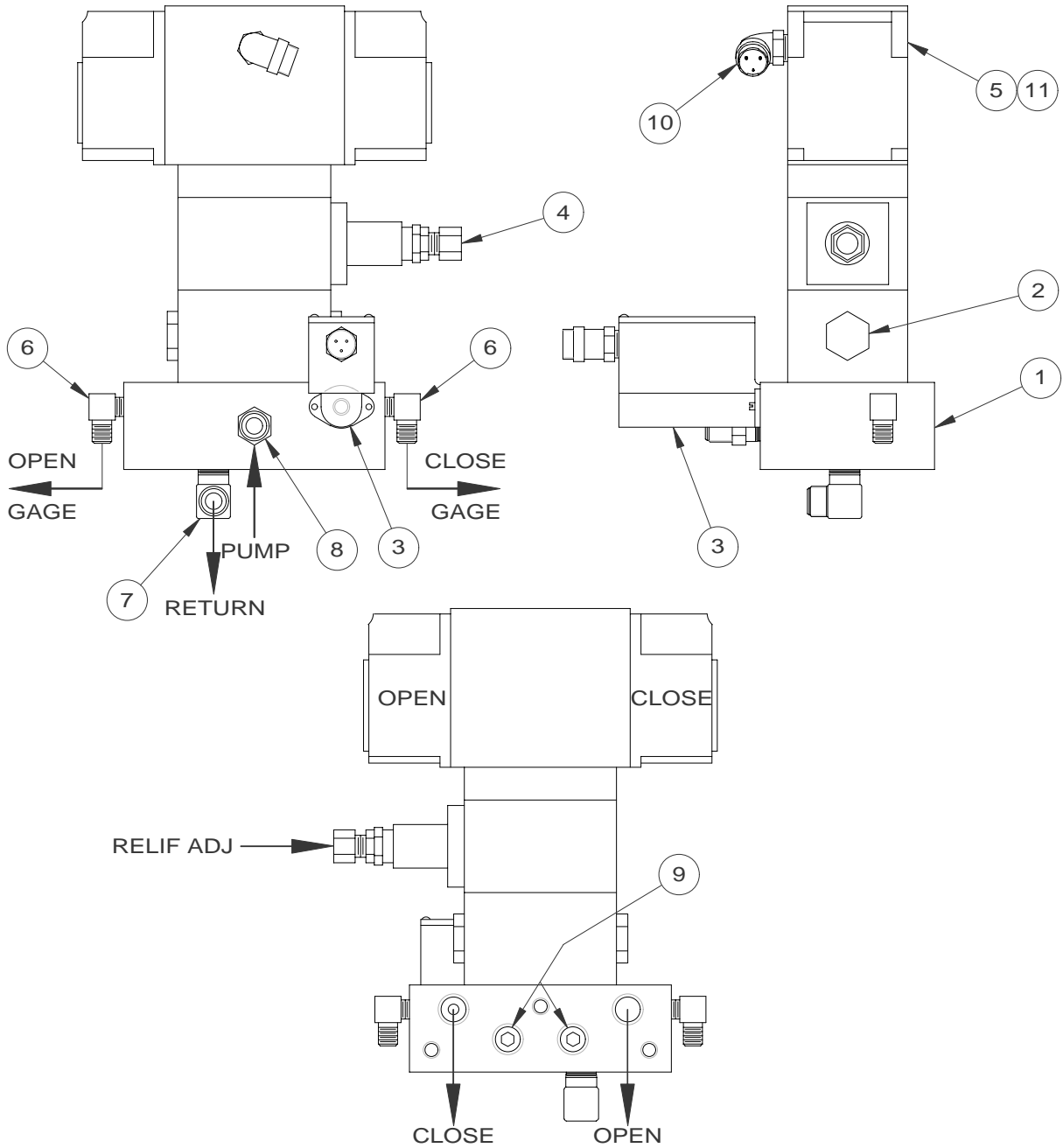



MODEL 66-80
VIBRATORY
DRIVER/EXTRACTOR

PARTS LIST

CLAMP MANIFOLD ASSEMBLY

810449

<u>Item</u>	<u>Part Number</u>	<u>Qty.</u>	<u>Description</u>
1	110642	1	Manifold Block
2	110149	1	Check Valve (CV-5)
3	810425	1	Pressure Switch (PS-1)
4	100898	1	Relief Valve (RV2)
5	110147	1	Control Valve (V-1)
6	140539	2	FITT2L-04M02P000-0000001
7	110632	1	FITT2L-12M06P000-000H001
8	110630	1	FITT2S-08M06P000-000H001
9	400213	2	FITT2P-06P000000-000S007
10	110235	1	90° S/O Cord Adapter
11	110634	4	.25 - 20 UNC x 7.50 Lg SHCS



MODEL 66-80
VIBRATORY
DRIVER/EXTRACTOR

PARTS LIST

196 CLAMP ASSEMBLY (OPTIONAL)

800315

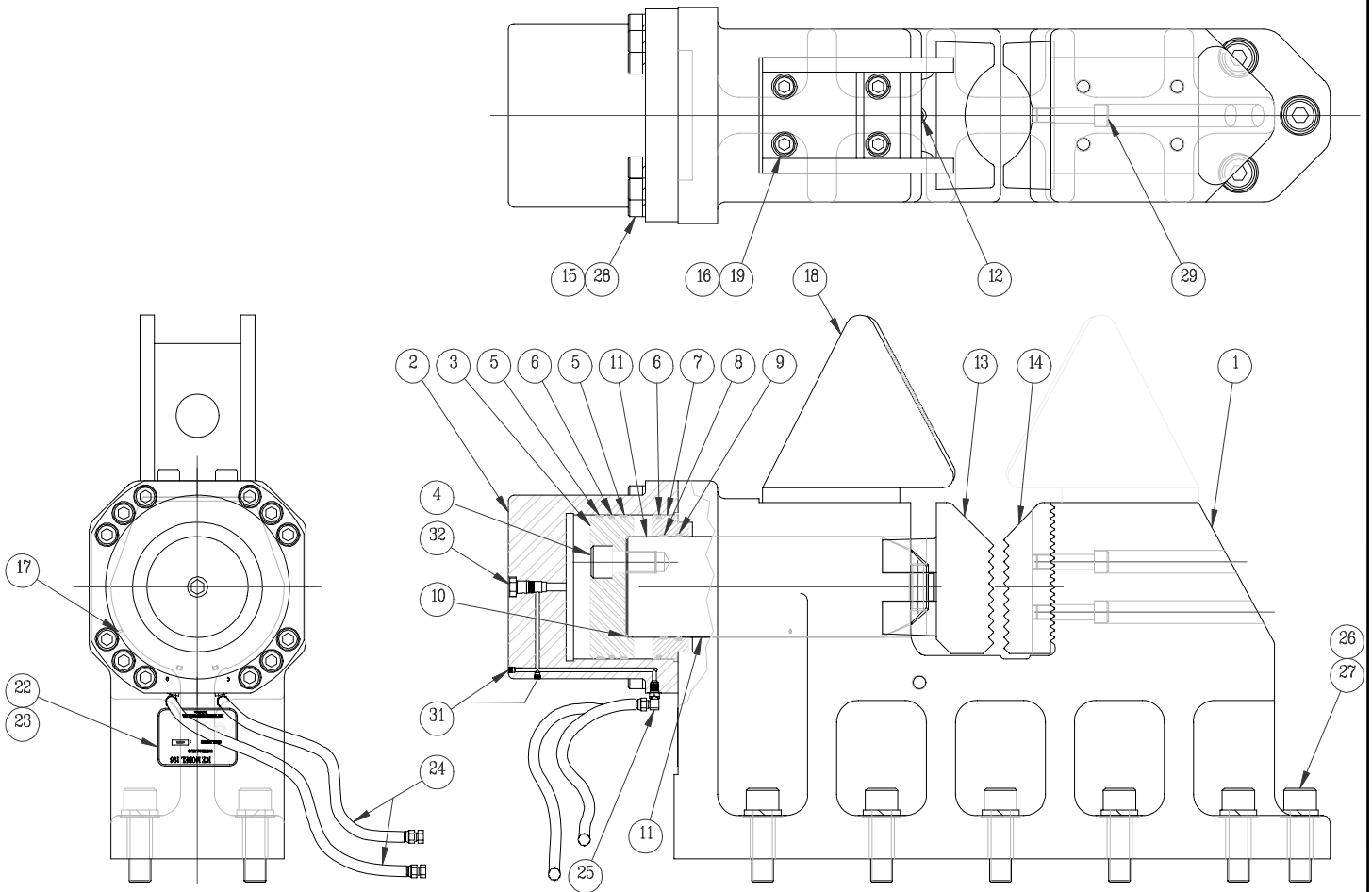



MODEL 66-80
VIBRATORY
DRIVER/EXTRACTOR

PARTS LIST

196 CLAMP ASSEMBLY (OPTIONAL)

800315

<u>Item</u>	<u>Part Number</u>	<u>Qty.</u>	<u>Description</u>
1	810457	1	196 Clamp Casting Assembly
2	810459	1	196 Cylinder
3	120537	1	196 Piston
4	120157	3	1.5-6 X 3.00 Lg SHCS
5	120551	2	Piston Bearing (Note)
6	120549	2	Seal (Note)
7	120539	1	196 Rod End Cap
8	120555	1	Rod Bearing (Note)
9	120553	1	Rod Seal (Note)
10	120347	1	2-261 O-Ring 90 Duro (Note)
11	120535	1	196 Cylinder Rod
12	130449	1	Roll Pin .75 X 3.00
13	810461	1	196 Moveable Jaw
14	810463	1	196 Fixed Jaw
15	140145	12	1.0-8 X 3.5 Lg SHCS
16	100209	4	1.00 Lock Washer Medium
17	100229	1	Grease Fitting
18	100983	1	Pile Feed Guide
19	100213	4	1.0-8 X 2.5 Lg SHCS Locwel
22	120561	1	196 S/N Plate
23	130381	4	Rivet
24	120193	2	HOSE038R02J006J006L132OS
25	130057	2	FITT2L-06M06R000-000H001
26	100193	11	1.5-6 X 5.0 Lg SHCS
27	100195	11	1.5 Lock Washer Extra Heavy
28	400787	12	1" H. C. Lock Washer
29	100212	2	1.0-8 X 4 LG SHCS Locwel
30	810473	1	196 Seal Kit
31	100646	4	FITT2P-02P000000-000S007
32	120629	1	Holding Valve Cartridge (CV7)

Note: Included in 196 Seal Kit



MODEL 66-80
VIBRATORY
DRIVER/EXTRACTOR

PARTS LIST

CLAMP EXTENSION - 10 FOOT (OPTIONAL)

800423

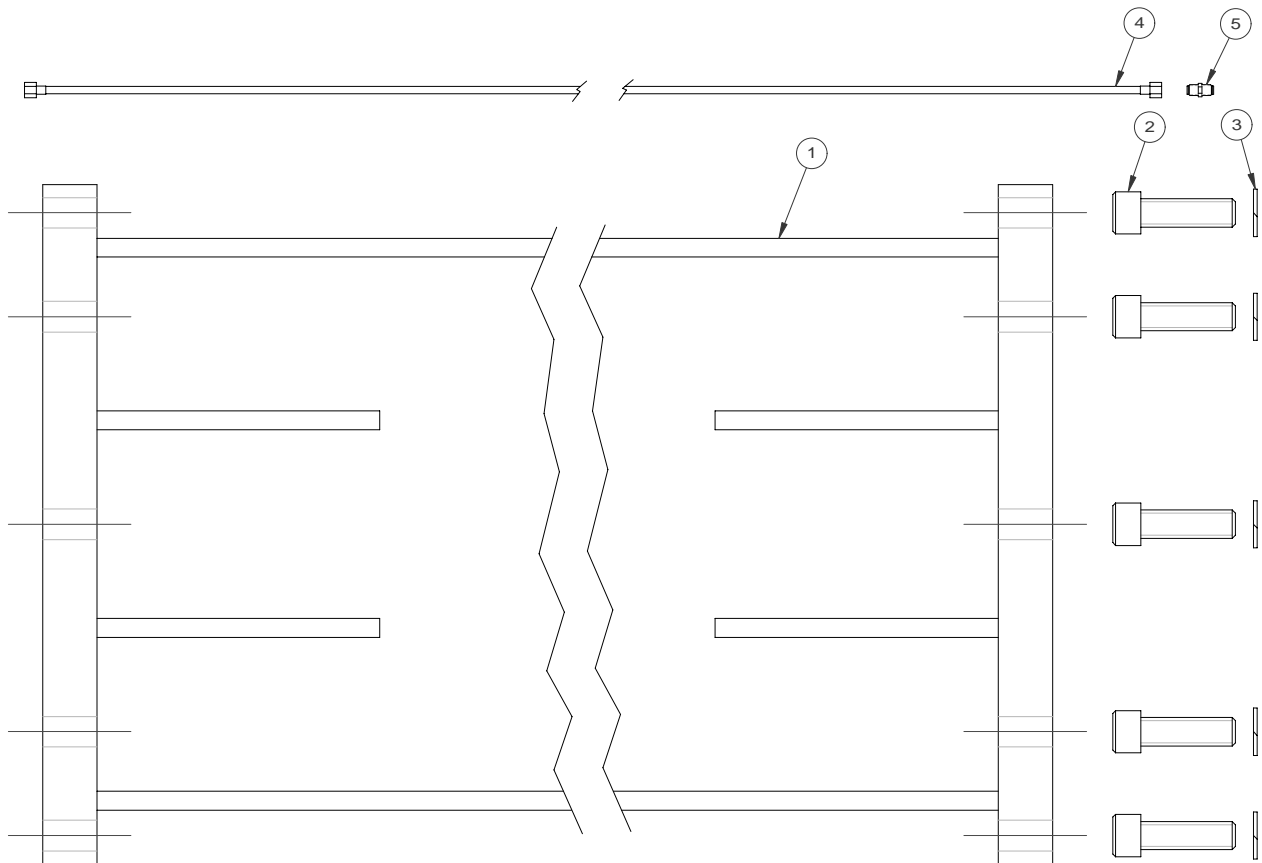

Item	Part Number	Qty.	Description
1	810655	1	10' Extension
2	100193	10	1.50-6UNC x 5.00 Lg SHCS
3	100195	10	1.50 Lock Washer
4	120193	2	HOSE038R02J006J006L1320S
5	120081	2	FITT2S-06M06M000-000H001



MODEL 66-80
VIBRATORY
DRIVER/EXTRACTOR

PARTS LIST

90 Deg. CLAMP ADAPTER (OPTIONAL) 800049

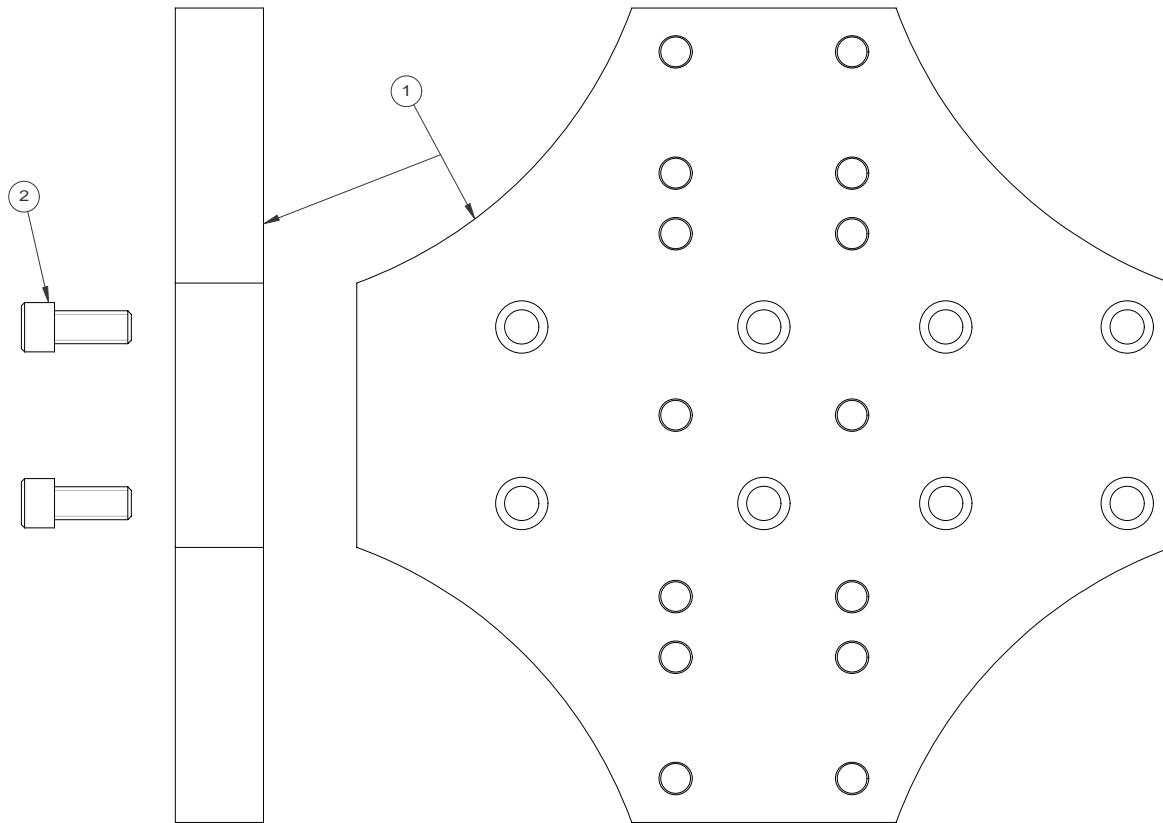

<u>Item</u>	<u>Part Number</u>	<u>Qty.</u>	<u>Description</u>
1	120083	1	90 deg. Clamp Adapter
2	120077	8	1.50-6UNC x 3.50 Lg SHCS



**MODEL 66-80
VIBRATORY
DRIVER/EXTRACTOR**

PARTS LIST

CAISSON BEAM - 7 FOOT (OPTIONAL)

800517

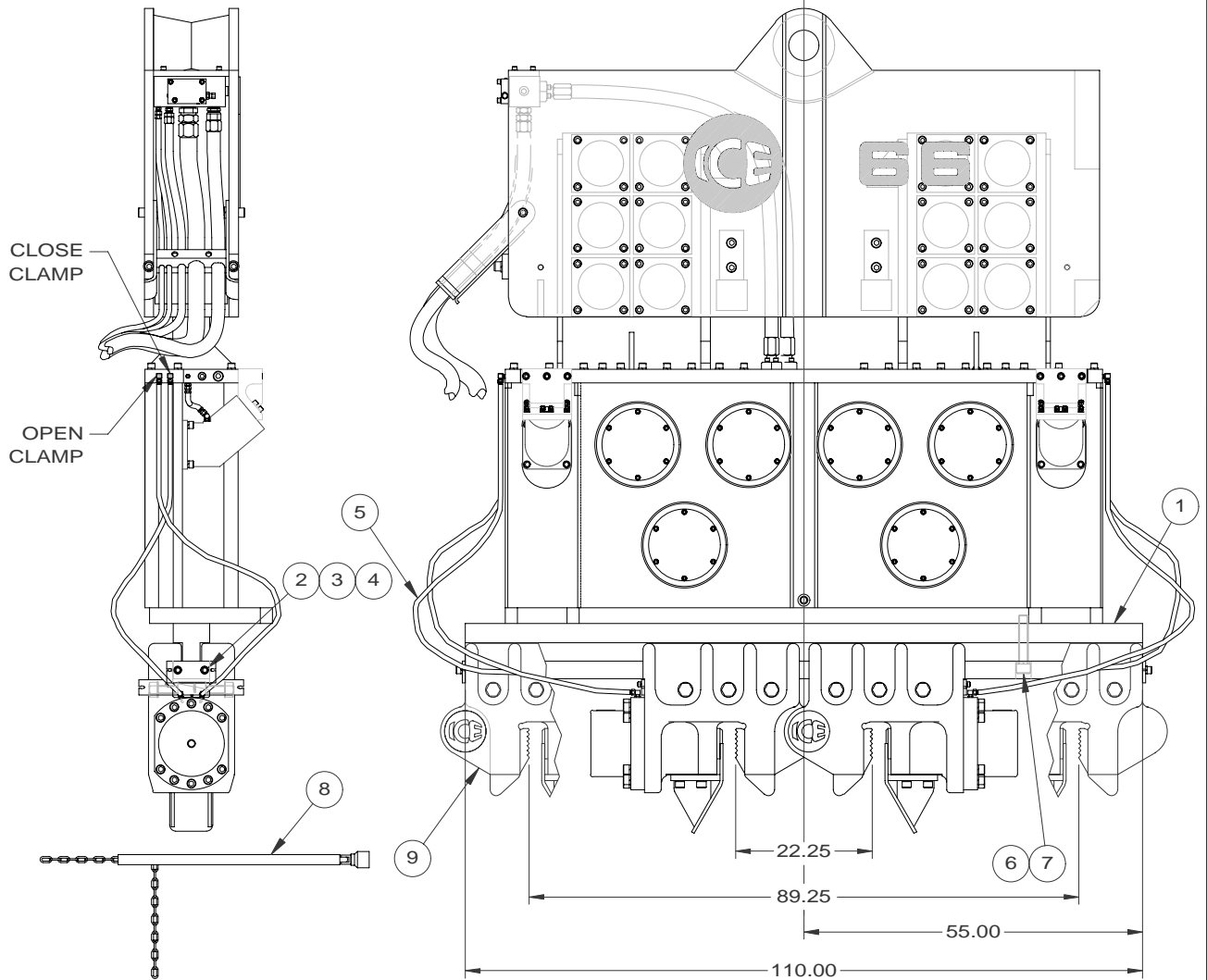

Item	Part Number	Qty.	Description
1	120001	1	7' Caisson Beam
2	120011	2	Clamp Stop
3	400069	4	.75-10UNC x 2.00 Lg SHCS
4	100069	4	.75 Lock Washer
5	130175	4	HOSE038R02J006J006L1150C
6	120007	15	1.50-6UNC x 8.00 Lg SHCS
7	130219	15	1.50 Lock Washer Hi-Collar
8	810173	1	Adjustment Tool
9	800409	2	#122 Caisson Clamp Asm. (Note)
12	100230	4	FITT2P-06M000000-000T001

Note: Not part of Caisson Beam Asm.



MODEL 66-80
VIBRATORY
DRIVER/EXTRACTOR

PARTS LIST

CAISSON BEAM - 11 FOOT (OPTIONAL)

800519

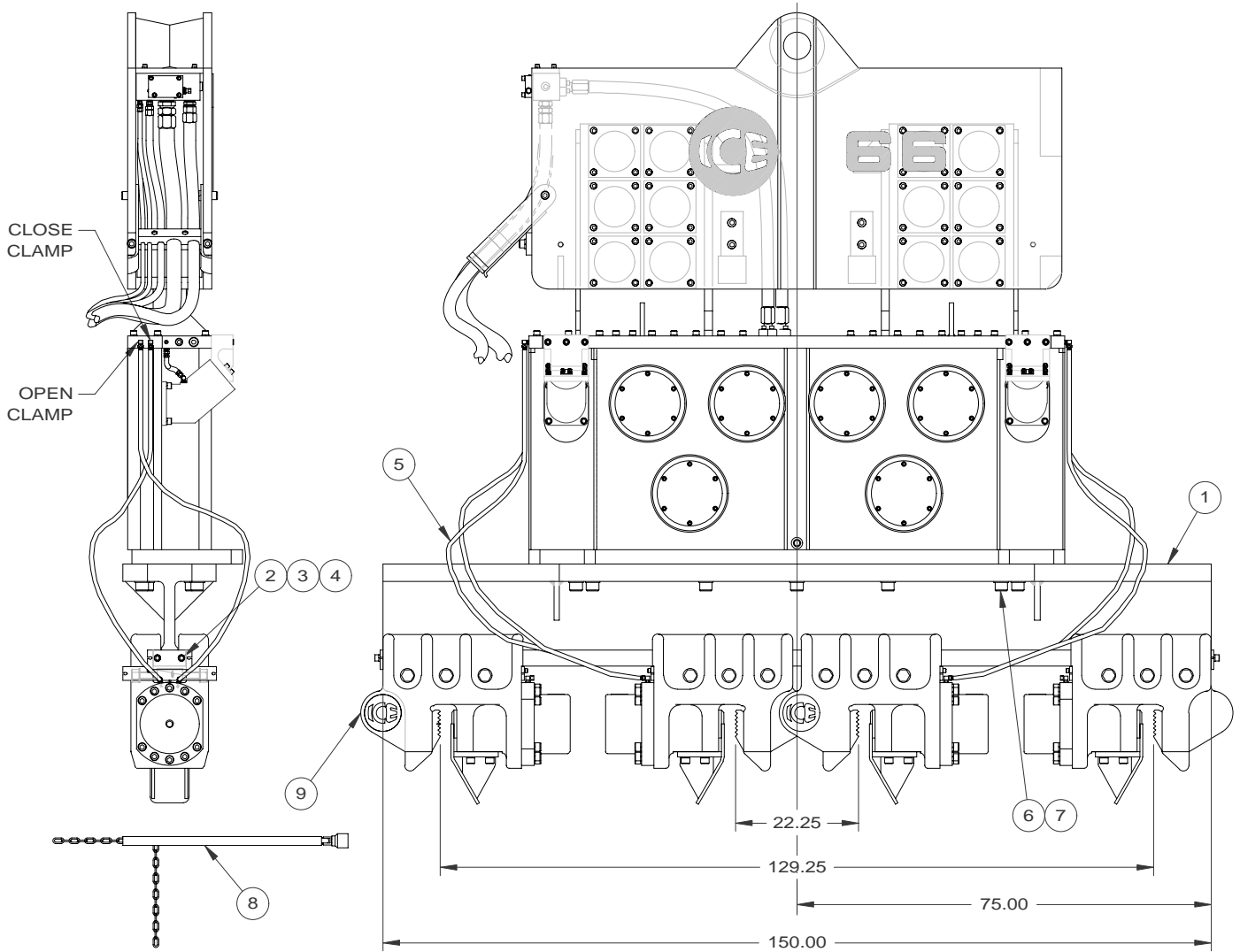

Item	Part Number	Qty.	Description
1	810251	1	11' Caisson Beam
2	120011	2	Clamp Stop
3	400069	4	.75-10UNC x 2.00 Lg SHCS
4	100069	1	.75 Lock Washer
5	130175	4	HOSE038R02J006J006L1150C
6	100193	14	1.50-6UNC x 5.00 Lg SHCS
7	130219	14	1.50 Lock Washer Hi-Collar
8	810173	1	Adjustment Tool
9	800409	2	#122 Caisson Clamp Asm. (Note)
12	100230	4	FITT2P-06M000000-000T001

Note: Not part of Caisson Beam Asm.



MODEL 66-80
VIBRATORY
DRIVER/EXTRACTOR

PARTS LIST

MODEL 122 CAISSON CLAMP (OPTIONAL)

800409

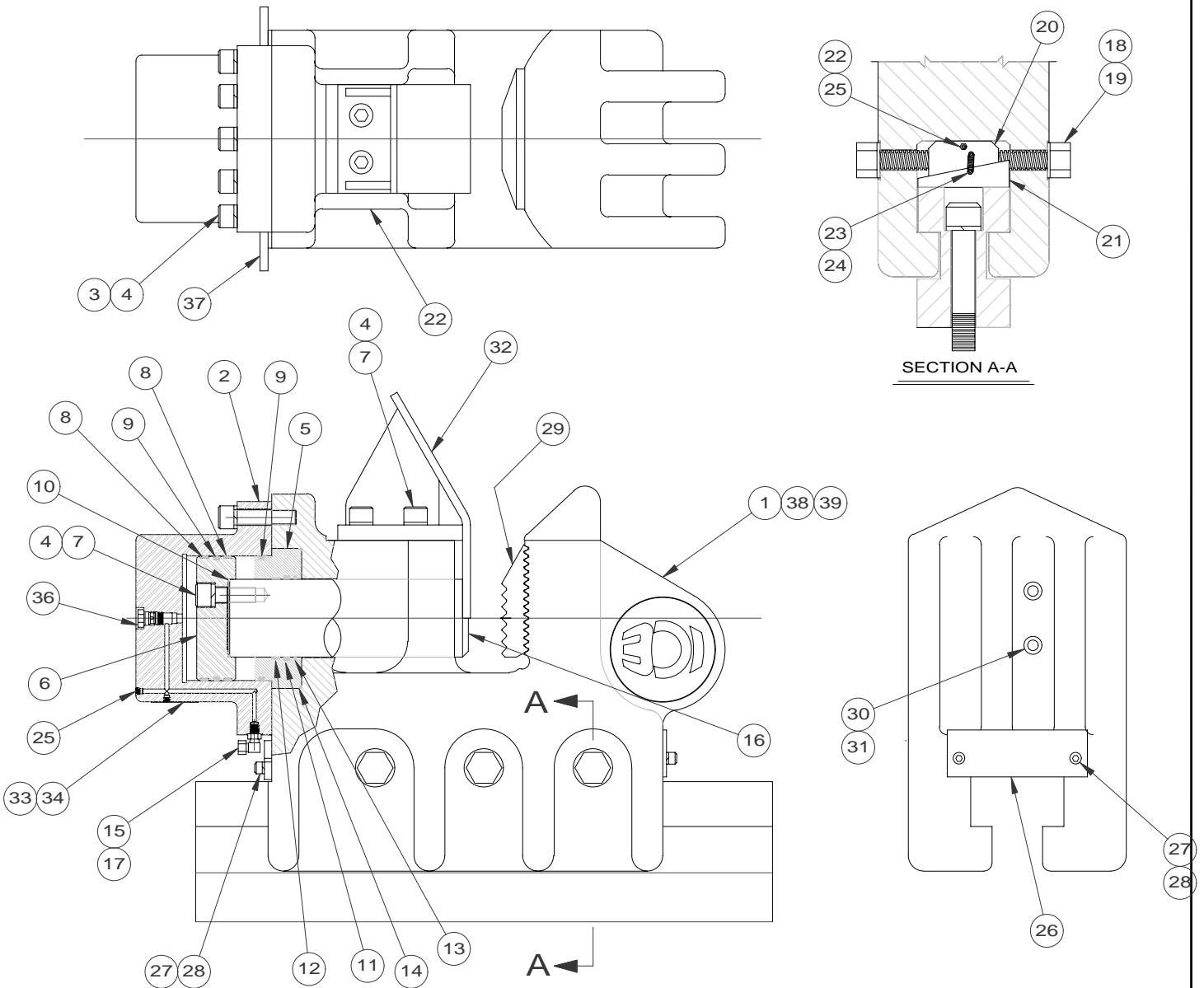



MODEL 66-80
VIBRATORY
DRIVER/EXTRACTOR

PARTS LIST

MODEL 122 CAISSON CLAMP (OPTIONAL)

800409

<u>Item</u>	<u>Number</u>	<u>Qty.</u>	<u>Description</u>
1	810183	1	122 Clamp Body
2	810491	1	126 Cylinder
3	100212	10	1.0-8 X 4 Lg SHCS Locwel
4	100209	17	1.0 Lockwasher Medium
5	120633	1	Rod End Cap
6	120635	1	Piston
7	100213	7	1.0-8 X 2.5 Lg SHCS Locwel
8	120285	2	Piston Bearing (Note)
9	120283	2	Piston Seal (Note)
10	120683	1	248-O-Ring (Note)
11	120685	1	Rod Seal (Note)
12	120687	1	Rod Bearing (Note)
13	120289	1	Rod Wiper (Note)
14	120401	1	2-269 O-Ring 90 Duro (Note)
15	130057	2	FITT2L-06M06R000-000H001
16	120637	1	Cylinder Rod
17	100057	2	FITT2C-06J000000-000H001
18	810109	3	Caisson 80 Screw Asm
19	120111	6	1.25 H. S. Flat Washer
20	120101	3	Wedge
21	120103	3	Lock
22	100229	4	Grease Fitting
23	120113	12	.25 X 1.00 Type G Drive Pin
24	120115	6	Spring
25	100646	7	FITT2P-02P000000-000S007
26	120119	1	Wedge Guard
27	100119	4	.5-13 X 1.25 Lg SHCS Locwel
28	100121	4	.5 Lock Washer Medium
29	120261	1	Fixed Jaw
30	100773	2	.625-11 X 4.5 Lg SHCS
31	100007	2	.625 Lock Washer Medium
32	120259	1	Caisson Head Guide
33	120335	1	122 S/N Plate
34	130381	4	Rivet
35	810633	1	122 Seal Kit
36	120629	1	Holding Valve Cartridge
37	120689	1	Chain Anchor

Note: Included in Model 80 Seal Kit.



MODEL 66-80
VIBRATORY
DRIVER/EXTRACTOR

PARTS LIST



MODEL 66-80
VIBRATORY
DRIVER/EXTRACTOR

PARTS LIST

PENDANT EXTENSION CABLE - 50' (OPTIONAL)

800059

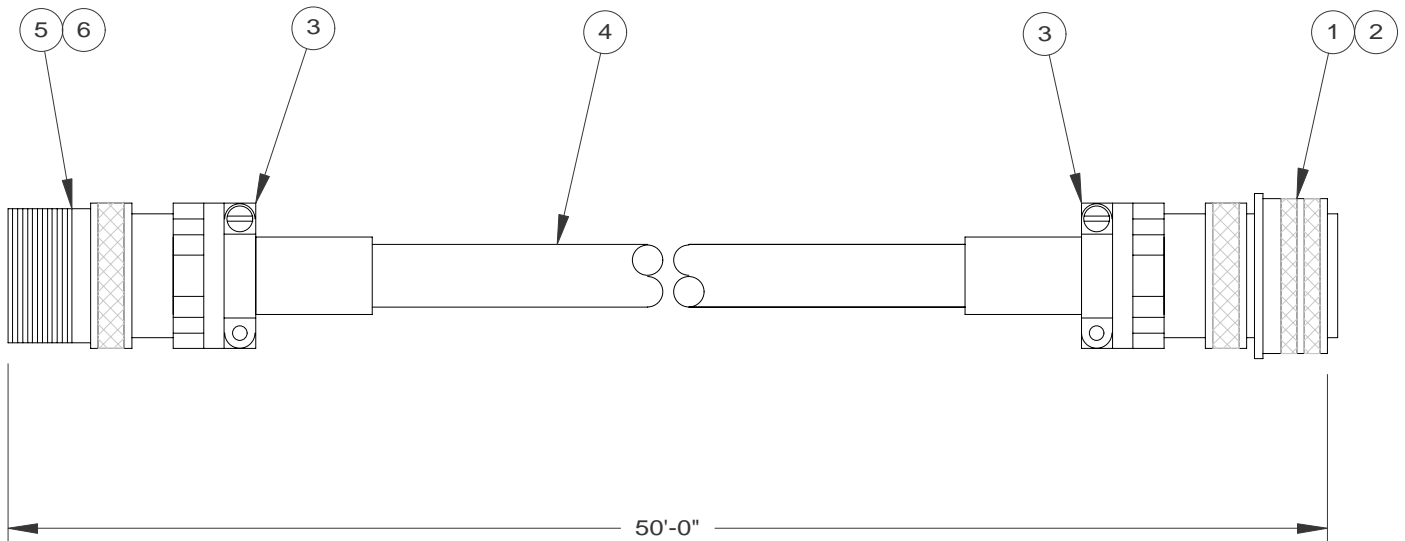

<u>Item</u>	<u>Part Number</u>	<u>Qty.</u>	<u>Description</u>
1	100395	1	Amphenol Plug
2	110761	1	Male Amphenol Insert-Plug
3	100375	2	Strain Relief - Amphenol
4	100560	50	Pendant Cable / Ft
5	120169	1	Amphenol Cable Jack
6	110763	1	Female Amphenol Insert



MODEL 66-80
VIBRATORY
DRIVER/EXTRACTOR

PARTS LIST

VIII. ORDERING PARTS

E. MISCELLANEOUS ACCESSORIES

1. TOOLS

Part Number	Qty.	Description
100651	1	24-Volt Test Light
810045	1	Set of Allen Wrenches - Includes All Wrenches Shown Below:
100655		(1) 1/16" Allen Wrench - Long Arm
100691		(1) 5/64" Allen Wrench - Long Arm
100659		(1) 3/32" Allen Wrench - Long Arm
100661		(1) 7/64" Allen Wrench - Long Arm
100663		(1) 1/ 8" Allen Wrench - Long Arm
100665		(1) 9/64" Allen Wrench - Long Arm
100667		(1) 5/32" Allen Wrench - Long Arm
100669		(1) 3/16" Allen Wrench - Long Arm
100671		(1) 7/32" Allen Wrench - Long Arm
100673		(1) 1/ 4" Allen Wrench - Long Arm
100657		(1) 5/16" Allen Wrench - Long Arm
100675		(1) 3/ 8" Allen Wrench - Long Arm
100677		(1) 7/16" Allen Wrench - Long Arm
100679		(1) 9/16" Allen Wrench - Long Arm
100683		(1) 5/ 8" Allen Wrench - Long Arm
100685		(1) 3/ 4" Allen Wrench - Long Arm
100687		(1) 7/ 8" Allen Wrench - Short Arm
100689		(1) 1" Allen Wrench - Short Arm

2. BULK

Part Number	Qty.	Description
810013	5 GAL	Hydraulic Oil
810011	5 GAL	Vibration Case Lubricant
100726	1 GAL	Coolant/Anti-Freeze
100298	1 GAL	APE / J&M Yellow Paint
100299	1 GAL	Primer



MODEL 66-80
VIBRATORY
DRIVER/EXTRACTOR

PARTS LIST

VIII. ORDERING PARTS

E. MISCELLANEOUS ACCESSORIES (Continued)

3. 66 HOSE GROUP KIT-INTERNAL

850127

Item	P/N	Qty.	Description	Page Ref.
15	140907	2	HOSE150PT6F024F024L0835C	VIII-6
23	100486	2	HOSE050R01J008J008L01450	VIII-6
27	140905	2	HOSE038R02J006J006L0835C	VIII-6
32	140903	1	HOSE075PT4F012FO12L0835C	VIII-6

4. 800 HOSE GROUP KIT-INTERNAL

850113

Item	P/N	Qty.	Description	Page Ref.
9	140753	1	HOSE200R01J032J032L17200	VIII-26
10	140755	1	HOSE200R01J032J032L18300	VIII-26
11	130393	1	HOSE019AQ1J004J004L11000	VIII-26
12	140735	2	HOSE025R02J004J004L11700	VIII-26
33	140715	1	HOSE125PT4H020H924L05600	VIII-27
34	140717	1	HOSE125PT4H020H924L06400	VIII-27
35	140719	1	HOSE125PT4J020H924L02200	VIII-27
36	140721	1	HOSE125PT4J020H924L03200	VIII-27
38	100108	1	HOSE038R02J006J006L0200S	VIII-27
44	400215	1	HOSE100R01P016P016L08400	VIII-27
48	300115	1	HOSE075R01J012J012L02600	VIII-27
61	140845	1	HOSE200R01J032J032L13900	VIII-27
62	140849	1	HOSE200R01J032J032L15000	VIII-27
67	140729	1	HOSE200R01J032F032L09000	VIII-27
68	140727	1	HOSE200RO1J032J032L09900	VIII-28
69	140723	1	HOSE150RO1J024F024L04800	VIII-28
70	140725	1	HOSE150R01J024F024L08700	VIII-28
94	140990	1	HOSE100R01J016J016L08000	VIII-28
136	140875	1	HOSE100R01P016J016L04400	VIII-29
138	140745	1	HOSE050PT4J008J008L04900	VIII-29
153	140737	2	HOSE038PT4J006J006L04200	VIII-30
162	100486	2	HOSE050R01J008J008L01450	VIII-30
163	140741	1	HOSE050R01J008J008L03800	VIII-30
164	140743	1	HOSE050RO1J008J008L07000	VIII-30
167	110633	1	HOSE038R02J006J006L0370S	VIII-30
178	140747	1	HOSE075R01J012J012L08800	VIII-30



MODEL 66-80
VIBRATORY
DRIVER/EXTRACTOR

PARTS LIST

VIII. ORDERING PARTS

E. MISCELLANEOUS ACCESSORIES (CONTINUED)

5. 66-880 / 800 O-RING KIT 850153

<u>P/N</u>	<u>Qty.</u>	<u>Description</u>
140255	2	#113-O-Ring
100097	2	#214-O-Ring
100037	8	#222-O-Ring
110119	17	#225-O-Ring
140233	5	#228-O-Ring
400379	4	#232-O-Ring

6. CYLINDER SEAL KITS

MODEL 254/196 CLAMP CYLINDER 800315 Refer to page VIII-38

<u>Item</u>	<u>P/N</u>	<u>Qty.</u>	<u>Description</u>
5	120551	2	Piston Bearing
6	120549	2	Piston Seal
8	120555	1	Rod Bearing
9	120553	1	Rod Seal
10	120347	1	#261-O-Ring

MODEL 122 CLAMP CYLINDER 800409 Refer to page VIII-44

<u>Item</u>	<u>P/N</u>	<u>Qty.</u>	<u>Description</u>
8	120285	2	Piston Bearing
9	120283	2	Piston Seal
10	120683	1	#248-O-Ring
11	120685	1	Rod Seal
12	120687	1	Rod Bearing
13	120289	1	Rod Wiper
14	120401	1	#269-O-Ring



**MODEL 66-80
VIBRATORY
DRIVER/EXTRACTOR**

PARTS LIST

VIII. ORDERING PARTS

F. RECOMMENDED SPARE PARTS

VIBRATION SUPPRESSOR 800487 Refer to page VIII-6

<u>Item</u>	<u>P/N</u>	<u>Qty.</u>	<u>Description</u>
41	100796	2	Elastomer
30	110119	4	#225 O-Ring
34	100097	1	#214 O-Ring
48	100037	4	#222 O-Ring

VIBRATION CASE 810649 Refer to page VIII-10

<u>Item</u>	<u>P/N</u>	<u>Qty.</u>	<u>Description</u>
6	100187	2	FITT2P-12P000000-000S0M7
15	100185	1	Sight Gage

HOSE ASSEMBLIES-INTERCONNECTING 800433 Refer to page VIII-14

<u>Item</u>	<u>P/N</u>	<u>Qty.</u>	<u>Description</u>
4	140683	1	HOSE200R13J032J032L60000
10	140685	1	HOSE100PT4P016P016L62000
14	100247	1	HOSE038R02P006P006L62000
18	110970	1	HOSE200R09J032J032L60000

POWER UNIT - INTERNAL 800385 Refer to page VIII-24

<u>Item</u>	<u>P/N</u>	<u>Qty.</u>	<u>Description</u>
10	110119	10	#225-O-Ring
33	140715	1	HOSE125PT4H020H924L05600
34	140717	1	HOSE125PT4H020H924L06400
35	140719	1	HOSE125PT4J020H924L02200
36	140721	1	HOSE125PT4J020H924L03200
51	140403	4	Filter Element
138	140745	1	HOSE050PT4J008J008L04900
---	140549	2	Air Cleaner Element



MODEL 66-80
VIBRATORY
DRIVER/EXTRACTOR

PARTS LIST

VIII. ORDERING PARTS

F. RECOMMENDED SPARE PARTS (CONTINUED)

TERMINAL MANIFOLD 810751 Refer to page VIII-12

<u>Item</u>	<u>P/N</u>	<u>Qty</u>	<u>Description</u>
5	110214	1	Relief Valve
13	110119	2	#225 O-Ring
16	100097	1	#214 O-Ring
21	140255	2	#113 O-Ring

MODEL 196 CLAMP 800315 Refer to page VIII-38

<u>Item</u>	<u>P/N</u>	<u>Qty.</u>	<u>Description</u>
12	130449	1	Spiral Roll Pin
13	810461	1	Movable Jaw
14	810463	1	Fixed Jaw
24	120193	2	HOSE038R02J006J006L1320S
25	130057	1	FITT2L-06M06R000-0000001
26	100193	11	1.5-6UNC x 5.00 Lg SHCS
27	100195	11	1.5 Lock Washer
28	400787	2	1.00 H.C. Lock Washer
29	100212	2	1.0-8 X 4.00 Lg. SHCS Locwel
30	810473	1	196 Seal Kit
32	120629	1	Holding Valve

MODEL 122 CAISSON CLAMP 800409 Refer to page VIII-44

<u>Item</u>	<u>P/N</u>	<u>Qty.</u>	<u>Description</u>
15	130057	2	FITT2L-06M06R000-000H001
18	810109	1	Screw Assembly
29	120261	1	Fixed Jaw
30	100773	2	.625-11UNC x 4.50 Lg SHCS
35	810633	1	Model 122 Seal Kit
36	120629	1	Holding Valve



**MODEL 66-80
VIBRATORY
DRIVER/EXTRACTOR**

PARTS LIST

G. RECOMMENDED TIGHTENING TORQUE

Nominal Screw Size	Nominal Socket Size	Tightening Torque Ft-Lbs. (Kg-M)	Nominal Screw Size	Nominal Socket Size	Tightening Torque Ft-Lbs. (Kg-M)
#10-24	5/32	6 Ft-Lbs. (.83 Kg-M)	#10-32	5/32	6 Ft-Lbs. (.83 Kg-M)
1/4-20	3/16	13 Ft-Lbs. (1.8 Kg-M)	1/4-28	3/16	15 Ft-Lbs. (2.1 Kg-M)
5/16-18	1/4	27 Ft-Lbs. (3.7 Kg-M)	5/16-24	1/4	30 Ft-Lbs. (4.2 Kg-M)
3/8-16	5/16	48 Ft-Lbs. (6.6 Kg-M)	3/8-24	5/16	55 Ft-Lbs. (7.6 Kg-M)
7/16-14	3/8	77 Ft-Lbs. (10.6 Kg-M)	7/16-20	3/8	86 Ft-Lbs. (11.9 Kg-M)
1/2-13	3/8	119 Ft-Lbs. (16.4 Kg-M)	1/2-20	3/8	133 Ft-Lbs. (18.4 Kg-M)
5/8-11	1/2	234 Ft-Lbs. (32.3 Kg-M)	5/8-18	1/2	267 Ft-Lbs. (36.9 Kg-M)
3/4-10	5/8	417 Ft-Lbs. (57.6 Kg-M)	3/4-16	5/8	467 Ft-Lbs. (64.5 Kg-M)
7/8-9	3/4	676 Ft-Lbs. (93.4 Kg-M)	7/8-14	3/4	742 Ft-Lbs. (102.5 Kg-M)
1-8	3/4	1,009 Ft-Lbs. (139.4 Kg-M)	1-12	3/4	1,126 Ft-Lbs. (155.6 Kg-M)
1-1/4-7	7/8	1,600 Ft-Lbs. (221.1 Kg-M)	1-1/4-12	7/8	1,800 Ft-Lbs. (248.8 Kg-M)
1-1/2-6	1	2,800 Ft-Lbs. (387 Kg-M)	1-1/2-12	1	3,000 Ft-Lbs. (414.6 Kg-M)

NOTE: These values are for Socket head cap screws only. Button heads, Flat heads and Set screws have different values. Check the Allen Hand Book for correct torque specifications.



MODEL 66-80
VIBRATORY
DRIVER/EXTRACTOR

PARTS LIST