



US006672805B1

(12) **United States Patent**
White

(10) **Patent No.:** **US 6,672,805 B1**
(45) **Date of Patent:** **Jan. 6, 2004**

(54) **SYSTEMS AND METHODS FOR DRIVING LARGE DIAMETER CAISSONS**

(75) Inventor: **John L. White, Kent, WA (US)**

(73) Assignee: **American Piledriving Equipment, Inc., Kent, WA (US)**

(*) Notice: Subject to any disclaimer, the term of this patent is extended or adjusted under 35 U.S.C. 154(b) by 0 days.

5,549,168 A	8/1996	Sadler et al.	
5,609,380 A	3/1997	White	
5,653,556 A	8/1997	White	
5,794,716 A	8/1998	White	
6,039,508 A	3/2000	White	
6,386,295 B1 *	5/2002	Suver	405/232
6,427,402 B1	8/2002	White	
6,431,795 B2	8/2002	White	
6,447,036 B1	9/2002	White	
6,582,158 B1 *	6/2003	Van Stein	405/232

FOREIGN PATENT DOCUMENTS

GB 2043755 * 10/1980 405/232

* cited by examiner

Primary Examiner—Jong-Suk (James) Lee
(74) *Attorney, Agent, or Firm*—Michael R. Schacht; Schacht Law Office, Inc.

(21) Appl. No.: **10/260,116**

(22) Filed: **Sep. 27, 2002**

Related U.S. Application Data

(60) Provisional application No. 60/325,881, filed on Sep. 27, 2001.

(51) **Int. Cl.**⁷ **E02D 7/00; E02D 7/18; E21B 7/24**

(52) **U.S. Cl.** **405/232; 405/231; 405/249; 175/56; 175/135; 173/42; 173/44; 173/49**

(58) **Field of Search** **405/231, 232, 405/256, 257, 249; 175/56, 135, 171; 254/95, 97; 173/39, 42, 49, 40, 44, 162.1**

(56) **References Cited**

U.S. PATENT DOCUMENTS

3,686,877 A	*	8/1972	Bodin	405/249
5,117,925 A		6/1992	White	
5,263,544 A		11/1993	White	
5,355,964 A		10/1994	White	
5,544,979 A		8/1996	White	

(57) **ABSTRACT**

A system for driving a large diameter caisson into the ground, comprising a crane assembly, a plurality of vibratory devices, a clamp assembly, a suspension assembly, and a timing system. Each vibratory device generates a vibratory force. The clamp assembly rigidly secures each of the vibratory devices to one of a plurality of predetermined angularly spaced locations about the caisson. The suspension assembly connects the vibratory devices to the crane assembly such that transmission of vibratory forces from the vibratory devices to the crane assembly is inhibited. The timing system operatively connects the plurality of vibratory devices to synchronize the vibratory forces generated thereby.

19 Claims, 2 Drawing Sheets

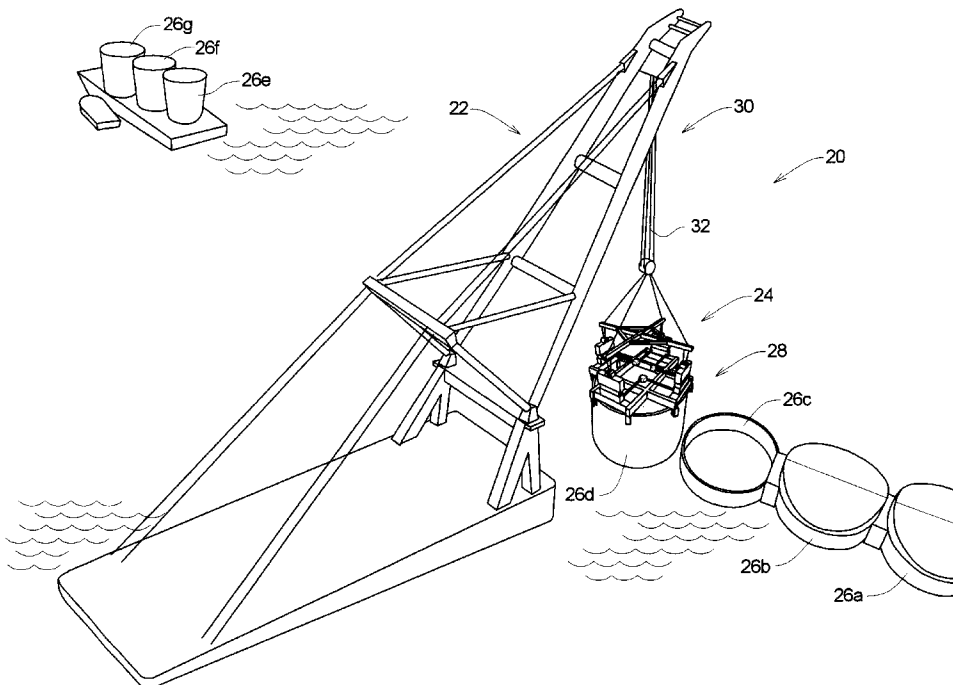

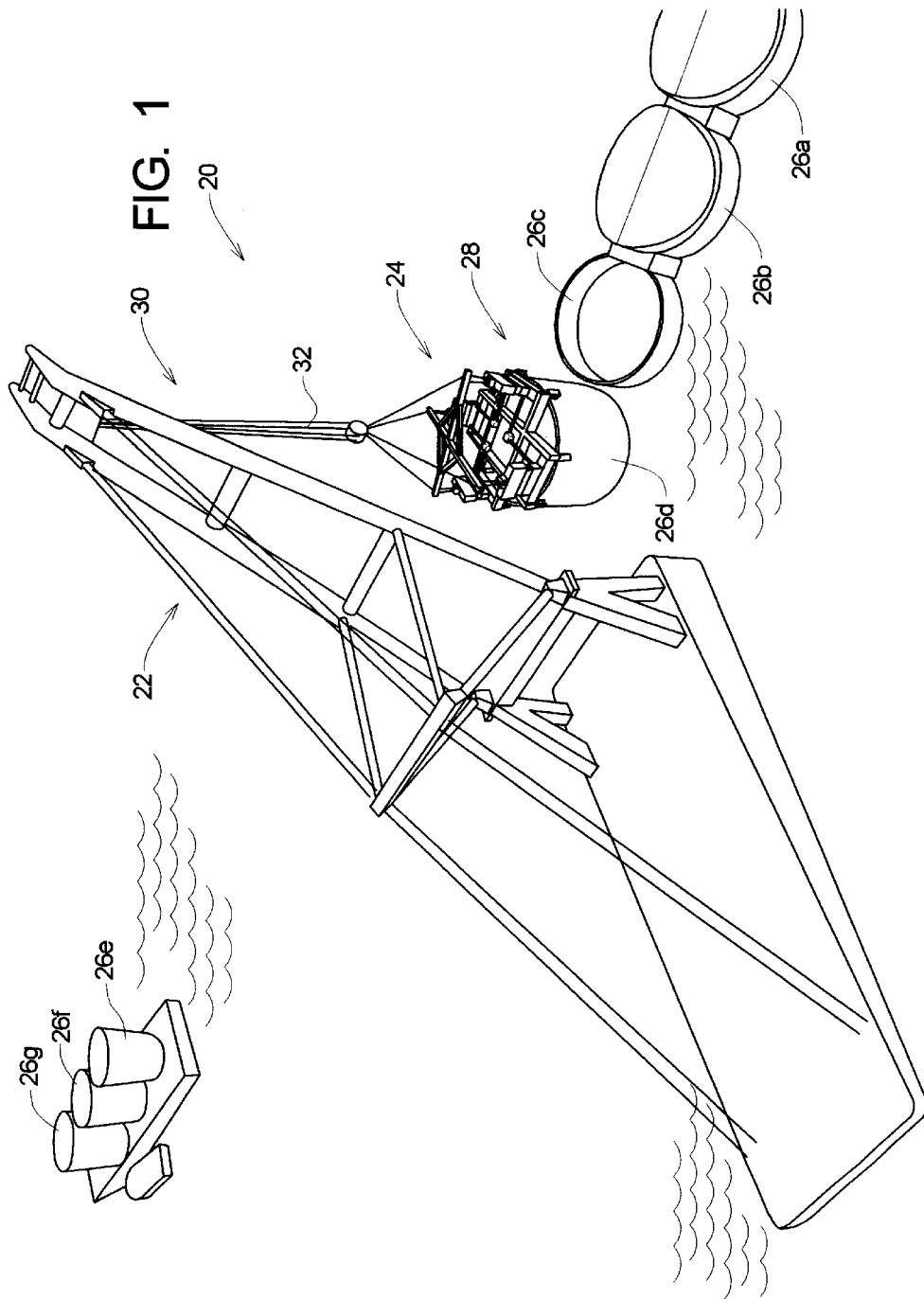
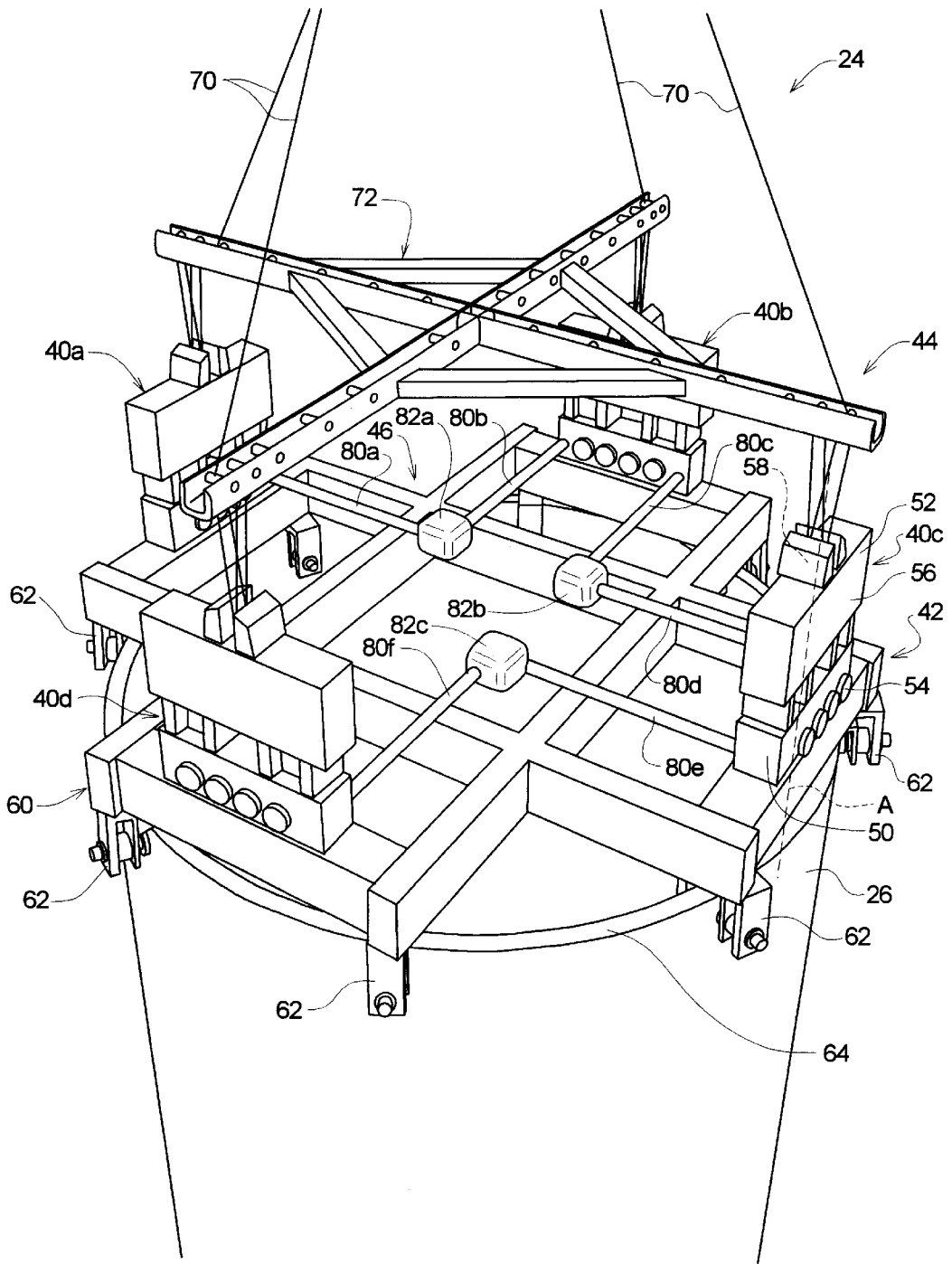

FIG. 2



SYSTEMS AND METHODS FOR DRIVING LARGE DIAMETER CAISSONS

RELATED APPLICATIONS

This application claims priority of U.S. Provisional Application Ser. No. 60/325,881, which was filed on Sep. 27, 2001.

TECHNICAL FIELD

The present invention relates to systems and methods for driving elongate members into the earth and, more particularly, to systems and methods adapted to drive large diameter caissons into the earth using vibration.

BACKGROUND OF THE INVENTION

In building, road, bridge, and other construction projects, the need often exists for driving elongate members into the ground. The elongate members may be solid, as in the case of wood or concrete piles, or they may be hollow. Hollow piles are typically made of plastic or metal.

The present invention relates to a specific type of hollow metal pile referred to as a caisson. More specifically, the present invention relates to systems and methods for driving large diameter, caissons into the ground.

U.S. Pat. Nos. 6,427,402, 6,431,795, and 6,447,036 to White disclose systems and methods for driving caissons into the earth. The systems and methods disclosed in these patents typically employ one or more vibratory devices, a clamp system for clamping the vibratory device(s) to the caisson, and a suppression system for inhibiting transmission of vibratory forces to a crane, spotter, or other system for holding the vibratory device in place. The caissons to be driven by the systems disclosed by these patents are typically less than 20 feet in diameter.

In some situations, the need exists to drive caissons of even larger diameter. For example, certain construction projects require that caissons with diameters exceeding 40 feet be driven into the ground. Although known caisson driving systems could be scaled up in size to drive such large diameter caissons, simply increasing the size of the driving system increases the costs and complexity of transporting and operating the driving system. The need thus exists for systems and methods for driving large diameter caissons that may use conventional vibratory systems and methods.

SUMMARY OF THE INVENTION

These and other objects may be obtained the systems and methods of the present invention. In particular, the present invention may be embodied as a system for driving a large diameter caisson into the ground comprising a crane assembly, a plurality of vibratory devices, a clamp assembly, a suspension assembly, and a timing system. Each vibratory device generates a vibratory force. The clamp assembly rigidly secures each of the vibratory devices to one of a plurality of predetermined angularly spaced locations about the caisson. The suspension assembly connects the vibratory devices to the crane assembly such that transmission of vibratory forces from the vibratory devices to the crane assembly is inhibited. The timing system operatively connects the plurality of vibratory devices to synchronize the vibratory forces generated thereby.

BRIEF DESCRIPTION OF THE DRAWINGS

FIG. 1 is a perspective view depicting a caisson driving system of the present invention; and

FIG. 2 is a perspective view depicting a vibratory system employed by the caisson driving system of FIG. 1.

DETAILED DESCRIPTION OF THE INVENTION

Referring now to FIG. 1, depicted at **20** therein is a caisson driving system constructed in accordance with, and embodying, the principles of the present invention. The exemplary caisson driving system **20** comprises a crane assembly **22** and a vibratory assembly **24** and is adapted to drive caissons **26** one at a time at a desired location **28**.

The crane assembly **22** is or may be conventional and comprises a rigid support structure **30** from which is suspended a crane line **32**. The vibratory assembly **24** is suspended from the crane line **32** above the desired location **28**.

The exemplary crane assembly **22** is barge mounted and thus adapted to drive the caissons **26** at a desired location under or near water; however, other crane assemblies may be used to implement the present invention. For example, the crane may be platform or track mounted for support and/or movement on land, and a plurality of smaller cranes may be used in place of one large crane.

Referring now to FIG. 2, the vibratory assembly **24** will now be described in further detail. The vibratory assembly **24** comprises a plurality of vibratory devices **40**, a clamp assembly **42**, a suspension assembly **44**, and a timing system **46**.

The vibratory devices **40** comprise a vibration unit **50** and a suppression unit **52**. The vibratory devices **40** are connected between the clamp assembly **42** and the suspension assembly **44** such that vibratory forces are transmitted along a vibratory axis A to the clamp assembly **42** but not to the suspension assembly **44**. In the exemplary vibratory assembly **24**, four vibratory devices **40** are used as will be described in further detail below.

In particular, the vibration units **50** may incorporate conventional counter-rotating eccentric weights **54** to translate rotational movement of the eccentric weights **54** into vibratory forces along the vibratory axis A. The suppression units **52** also are or may be conventional and employ a housing **56** rigidly connected to each vibration unit **50** and a plate **58** rigidly connected to the suspension assembly **44**. Resilient shock absorbing members (not shown) are connected between the housing **56** and the plate **58** such that only a portion of the vibration of the vibration unit **50** is transmitted to the plate **58** through the housing **56**. Suitable vibratory devices are sold by American Piledriving Equipment as Model Number 400.

The clamp assembly **42** comprises a clamp frame **60** and a plurality of clamping devices **62**. The clamping devices **62** are mounted to a lower surface of the clamp frame **60** and extend downwardly to clamp onto one of the caissons **26** and thereby secure the frame **60** relative to the caisson **26**. The clamp frame **60** is large enough to extend across the diameter of the caissons **26** such that the clamping devices **62** engage predetermined angularly spaced locations about an upper perimeter edge **64** of the caisson **26**.

In the exemplary vibratory assembly **24**, the clamp frame **60** is generally cruciform in shape and defines eight corner locations, with one clamping device **62** located at each corner location such that the clamping devices **62** spaced at forty-five degree increments about the caisson **26**. Other numbers and angular arrangements of clamping devices **62** are possible, and the exact details of the frame **60** are not critical as long as the frame **60** is capable of transmitting the vibratory forces of the vibratory devices **40** to the caisson **26**.

The suspension assembly 44 comprises a plurality of suspension cables 70 attached to the crane cable 32 and a suspension frame 72 that spaces the suspension cables above the vibratory devices 40.

The timing system 46 comprises a plurality of timing shafts 80 and gear boxes 82. In the exemplary vibratory assembly 24 having four vibratory devices 40, six timing shafts 80 and three gear boxes 82 are employed. Two of the shafts 80 extend into each of the three gear boxes 82. The gear boxes 82 translate axial rotation of one of the shafts 80 extending therein into axial rotation of the other of the shafts extending therein. Each of the shafts 80 further extends into one of the vibratory devices 40, with two of the vibratory devices 40 receiving two shafts 80 and two receiving one shaft 80.

The shafts 80 and gear boxes 82 mechanically interconnect the vibratory devices 40 such that the rotation of the eccentric weights 54 within the vibratory devices 40 is synchronized in both revolution speed and phase (as determined by angular location of the eccentric weights).

In particular, the vibratory devices 40 are connected in a daisy chain manner with one of the devices 40 being the master and the other of the devices being slaves. The revolution speed and phase of the master device 40a is transmitted through a first shaft 80a to a first gear box 82a, from the first gear box 82a through a second shaft 80b to first slave device 40b, from the first slave device 40b through a third shaft 80c to a second gear box 82b, from the second gear box 82b through a fourth shaft 80d to a second slave device 40c, from the second slave device 40c through a fifth shaft 80e to a third gear box 82c, and from the third gear box 82c through a sixth shaft 80f to a third slave device 40d.

The master/slave relationship among the various vibratory devices 40a-d ensures that the eccentric weights 54 therein counter-rotate in synchrony such that the vibratory forces created by the vibratory devices 40a-d are all in phase. The in-phase vibratory forces ensure that all four quadrants of the cruciform clamp frame 60 move up and down at the same time such that the effect of the vibratory forces is cumulative and not subtractive. The cumulative driving forces of the clamping devices 40a-d greatly increases the ability of the system 20 to drive the caissons 26 into the ground.

I claim:

1. A system for driving a large diameter caisson into the ground, comprising:
 - a crane assembly;
 - a plurality of vibratory devices, where each vibratory device generates a vibratory force;
 - a clamp assembly for rigidly securing each of the vibratory devices to one of a plurality of predetermined angularly spaced locations about the caisson;
 - a suspension assembly for connecting the vibratory devices to the crane assembly such that transmission of vibratory forces from the vibratory devices to the crane assembly is inhibited; and
 - a timing system operatively connecting the plurality of vibratory devices to synchronize the vibratory forces generated thereby.
2. A system as recited in claim 1, in which:
 - one of the vibratory devices is a master vibratory device;
 - another vibratory device is a slave vibratory device; and
 - the timing system causes the slave vibratory device to generate vibratory forces based on the operation of the master vibratory device.

3. A system as recited in claim 2, in which the timing system comprises:

- at least one gear box; and
- a plurality of shafts; where
 - a first shaft extends from the master vibratory device to the at least one gear box; and
 - operation of the master vibratory device causes operation of the slave vibratory device through the at least one gear box and the first and second shafts such that the vibratory forces generated by the slave vibratory device are synchronized with the vibratory forces generated by the master vibratory device.

4. A system as recited in claim 1, in which the timing system comprises:

- at least one gear box; and
- a plurality of shafts; where
 - each shaft extends between one of the vibratory devices and the at least one gear box; and
 - operation of one of the vibratory devices causes operation of another of the vibratory devices through the at least one gear box and the plurality of shafts such that the vibratory forces generated by the vibratory devices are synchronized.

5. A system as recited in claim 1, in which:

- one of the vibratory devices is a master vibratory device; the other vibratory devices are slave vibratory devices; and
- the timing system causes the slave vibratory devices to generate vibratory forces based on the operation of the master vibratory device.

6. A system as recited in claim 5, in which the timing system comprises:

- a plurality of gear boxes; and
- a plurality of shafts; where
 - a first shaft extends from the master vibratory device to a first gear box;
 - a second shaft extends from the first gear box to a first slave vibratory device;
 - a third shaft extends from the first slave vibratory device to a second gear box; and
 - a fourth shaft extends from the second gear box to a second slave vibratory device; wherein
 - operation of the master vibratory device causes operation of the first and second slave vibratory devices through the first and second gear boxes and the first, second, third, and fourth shafts such that the vibratory forces generated by the first and second slave vibratory devices are synchronized with the vibratory forces generated by the master vibratory device.

7. A system as recited in claim 5, in which the timing system comprises:

- first, second, and third gear boxes; and
- a plurality of shafts; where
 - a first shaft extends from the master vibratory device to the first gear box;
 - a second shaft extends from the first gear box to a first slave vibratory device;
 - a third shaft extends from the first slave vibratory device to the second gear box;
 - a fourth shaft extends from the second gear box to a second slave vibratory device;
 - a fifth shaft extends from the second slave vibratory device to the third gear box; and

5

a sixth shaft extends from the third gear box to a third slave vibratory device; wherein
operation of the master vibratory device causes operation of the first, second, and third slave vibratory devices through the first, second, and third gear boxes and the first, second, third, fourth, fifth, and sixth shafts such that the vibratory forces generated by the first, second, and third slave vibratory devices are synchronized with the vibratory forces generated by the master vibratory device.

8. A system as recited in claim 5, in which:
each vibratory device comprises at least two eccentric weights; and
the timing system comprises
at least one gear box; and
a plurality of shafts; wherein
each shaft is operatively connected between one of the eccentric weights and the at least one gear box; and
the shafts rotate based on rotation of the eccentric weights of the master vibratory device such that the eccentric weights of the slave vibratory devices rotate in synchrony with eccentric weights of the master vibratory device.

9. A system as recited in claim 1, in which the timing system interconnects the vibratory devices in a daisy chain configuration to synchronize the vibratory forces generated by the vibratory devices.

10. A system as recited in claim 1, in which:
each vibratory device comprises at least two eccentric weights; and
the timing system is operatively connected between the vibratory devices such that the eccentric weights rotate at substantially the same speed.

11. A system as recited in claim 10, in which the timing system comprises:
at least one gear box; and
a plurality of shafts; where
each shaft is operatively connected between one of the eccentric weights and the at least one gear box; and
the shafts are rotated with the eccentric weights such that the eccentric weights rotate in synchrony with each other.

12. A method of driving a large diameter caisson into the ground, comprising:
providing a plurality of vibratory devices for generating vibratory forces;
connecting the plurality of vibratory devices to a crane assembly such that transmission of vibratory forces from the vibratory devices to the crane assembly is inhibited;
rigidly securing each of the vibratory devices to one of a plurality of predetermined angularly spaced locations about the caisson;
operating each of the plurality of vibratory devices such that the vibratory devices each generate a vibratory force;
operatively connecting the plurality of vibratory devices together to synchronize the vibratory forces generated thereby.

13. A method as recited in claim 12, further comprising the steps of:
identifying one of the vibratory devices as a master vibratory device; and
identifying another vibratory device as a slave vibratory device; wherein

6

the step of operatively connecting the plurality of vibratory devices further comprises the step of operating the slave vibratory device to generate vibratory forces based on the operation of the master vibratory device.

14. A method as recited in claim 12, in which the step of operatively connecting the plurality of vibratory devices further comprises the step of interconnecting the vibratory devices in a daisy chain configuration to synchronize the vibratory forces generated by the vibratory devices.

15. A method as recited in claim 12, in which:
the step of providing the plurality of vibratory devices comprises the step of providing at least two eccentric weights; and
the step of operatively connecting the plurality of vibratory devices further comprises the step of operatively connecting the vibratory devices such that the eccentric weights rotate at substantially the same speed.

16. A method as recited in claim 15, in which the step of operatively connecting the plurality of vibratory devices further comprises the steps of:
providing at least one gear box;
providing a plurality of shafts;
operatively connecting each shaft between one of the eccentric weights and the at least one gear box; and
rotating the shafts with the eccentric weights such that the eccentric weights rotate in synchrony with each other.

17. A system for driving a large diameter caisson into the ground, comprising:
a crane assembly;
a plurality of vibratory devices, where each vibratory device comprises:
a housing; and
eccentric weights mounted within the housing, where rotating the eccentric weights in opposite directions generate vibratory forces;
a clamp assembly for rigidly securing each of the vibratory devices to one of a plurality of predetermined angularly spaced locations about the caisson;
a suspension assembly for connecting the housings of the vibratory devices to the crane assembly such that transmission of vibratory forces from the vibratory devices to the crane assembly is inhibited; and
a timing system comprising at least one gear box, and a plurality of shafts; where
each shaft extends between the eccentric weights of one of the vibratory devices and the at least one gear box; and
rotation of the eccentric weights of one of the vibratory devices is transmitted to rotation of the eccentric weights of another of the vibratory devices through the at least one gear box and the plurality of shafts such that the vibratory forces generated by the vibratory devices are synchronized.

18. A system as recited in claim 17, in which: one of the vibratory devices is a master vibratory device; another vibratory device is a slave vibratory device; and the timing system causes the slave vibratory device to generate vibratory forces based on the operation of the master vibratory device.

19. A system as recited in claim 18, in which the timing system interconnects the vibratory devices in a daisy chain configuration to synchronize the vibratory forces generated by the vibratory devices.