



## Understanding Cylinder Force vs Gripping Force

When driving piles it is very important to properly calculate the clamping force of each clamp. Non engineers commonly confuse the cylinder force equation with the clamping force equation. Please study the following equations. The actual clamping or gripping force is twice the cylinder force.

Cylinder force equation: Diameter squared X pie divided by 4 = area  
area X pressure = cylinder force

Gripping force of clamp: Diameter squared X pie divided by 4 = area  
area X pressure = cylinder force X 2 = **gripping force**

These equations are universal for Metric or English measurements.

### Principle of Clamping Force

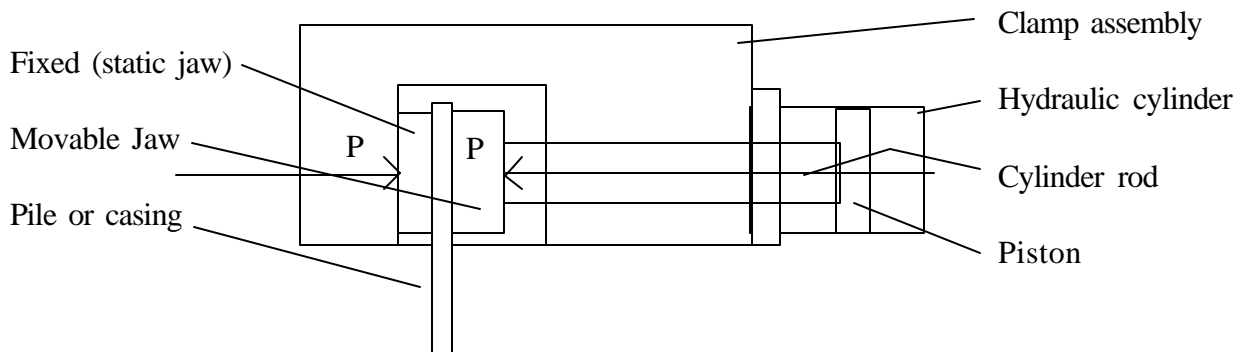

The clamping force “P” generated by the cylinder is counteracted by an equal and opposing force “P” (Static).

“P” is cylinder force

2P = gripping force

**Example for gripping force of APE standard casing clamps:**

$$20.3 \text{ cm}^2 \times 3.14 / 4 = 324.3 \text{ square cm}$$

(diameter)X(pie)/ 4 = area

**324.3 square cm X 340 bar = 110,306 kg X 2 = 220, 612 kg = 220 metric tons**  
**220 metric tons per clamp. If you use four clamps the combined total gripping force will equal: 880 metric tons (rounded numbers).**